

Honeywell

HF800

Fixed-Mount Industrial Scanner



User Guide

Disclaimer

Honeywell International Inc. (“HII”) reserves the right to make changes in specifications and other information contained in this document without prior notice, and the scanner should in all cases consult HII to determine whether any such changes have been made. HII makes no representation or warranties regarding the information provided in this publication.

HII shall not be liable for technical or editorial errors or omissions contained herein; nor for incidental or consequential damages resulting from the furnishing, performance, or use of this material. HII disclaims all responsibility for the selection and use of software and/or hardware to achieve intended results.

This document contains proprietary information that is protected by copyright. All rights are reserved. No part of this document may be photocopied, reproduced, or translated into another language without the prior written consent of HII.

Copyright © 2022 Honeywell International Inc. All rights reserved.

Web Address: sps.honeywell.com

Other product names or marks mentioned in this document may be trademarks or registered trademarks of other companies and are the property of their respective owners.

For patent information, refer to www.hsmpats.com.

TABLE OF CONTENTS

Customer Support	vii
Technical Assistance	vii
Product Service and Repair	vii
Limited Warranty	vii
Chapter 1 - Get Started	1
About This Manual.....	1
Model Description.....	1
Horizontal Model.....	2
Vertical Model.....	3
Package Contents	4
Accessories	4
Mounting Bracket (sold separately).....	4
Adapter and Plug Assembly	5
Power Requirements.....	5
Connect the Device.....	5
Connect with Ethernet.....	6
Connect with RS232.....	6
Connect with RS485.....	7
Direct PC Connection.....	7
Control Panel	8
Tune Button.....	9
Auto-Train Mode.....	9
Chapter 2 - Configuration Tool.....	11
Hardware Requirements	11

Software Requirements.....	11
How to Install.....	11
DataMax User Interface	12
Control and Help Toolbar	12
Status Bar	13
Device Discovery.....	13
Ethernet	13
Serial.....	13
Connect to a Device.....	14
Configurations.....	14
Load a Configuration.....	14
From a PC.....	14
From a Device.....	14
Save a Configuration	15
To a PC.....	15
To a Device.....	15
Settings.....	15

Chapter 3 - Tuning..... 17

Live View.....	17
Crop	17
Save.....	18
Log View	18
Save.....	18
Clear.....	18
Statistics.....	18
Auto-Train Tuning.....	19
Image Setup.....	19
Bank Setting	20
Aimer & Light	20
Charts Panel	20

Chapter 4 - Interfaces..... 21

Network Setup.....	21
Network Grouping	21

Set Up a Network Group.....	22
View Existing Network Grouping.....	23
Serial Interface Setup.....	23

Chapter 5 - Operating Modes25

Internal Trigger Mode.....	25
External Trigger Mode.....	25
Trigger Through Remote Commands.....	26
Presentation Mode.....	27
Streaming Presentation Mode.....	27

Chapter 6 - Symbologies.....29

Message Length Description.....	30
Symbologies Tab.....	30
Enable Symbologies.....	30
Disable Symbologies.....	30
2D Symbologies.....	31
Aztec.....	31
Maxicode.....	31
HanXin.....	31
DataMatrix.....	31
QR Code.....	32
Dot Code.....	32
Linear Symbologies.....	32
Code 11.....	32
Code 128.....	32
Code 39.....	33
Codabar.....	34
Code 93.....	35
EAN-13.....	35
EAN-8.....	36
GS1-128.....	36
GS1 DataBar.....	36

GS1 DataBar Limited.....	36
GS1 DataBar Expanded.....	37
Interleaved 2 of 5.....	37
MSI.....	37
UPC-A.....	38
UPC-E.....	38
Stacked Linear Symbologies.....	39
PDF417.....	39
MicroPDF.....	39
Codablock A.....	39
Codablock F.....	39
Postal Codes - 2D.....	39
Australian Post.....	40
Planet Code.....	40
Postnet.....	40
Chapter 7 - Decoder Configuration.....	41
General Decoding Settings.....	41
Output Sequences.....	42
Matching Rules.....	43
Code Items.....	44
Add or Modify an Output Sequence.....	44
Chapter 8 - Input/Output Settings.....	45
Input Channel Settings.....	45
Polarity and Debounce Time.....	45
Output Channel Settings.....	46
Chapter 9 - Data Editing and Formatting.....	49
Prefix/Suffix Overview.....	49
Add a Prefix/Suffix.....	49
Remove a Prefix/Suffix.....	50
Data Format Editor Introduction.....	50
Add a Data Format.....	50

Delete a Data Format	52
Advance Mode (Command Line)	52

Chapter 10 - Maintenance and Troubleshooting53

Software and Firmware.....	53
Software Downloads.....	53
Firmware Upgrades	53
Restore Factory Defaults.....	54
Reset with the Tune Button.....	54
Reset with DataMax.....	54
Repairs.....	54
Maintenance.....	55
Clean the Scanner.....	55
Inspect Cords and Connectors.....	55
Troubleshooting.....	55

Appendix A - Product Specifications.....57

HF800 Product Specifications	57
Depth of Field	58
Field of View Calculation	58
Connector Pinouts.....	59
HF800 D-Sub 25-Pin Male Connector	59
Output.....	60
Input.....	61
NPN	62
PNP.....	63
RS232	63
RS485 and RS422.....	63
Ethernet M12 Connector	64
Terminal Pinouts.....	64

External I/O+RS232 Cable.....	64
I/O+RS232 Discrete Wiring Cable.....	65
External I/O+RS485/422 Cable	66
Ethernet Cable	67
Required Safety Labels	68

Appendix A - Barcodes..... 69

Network DHCP.....	69
Reboot the Scanner	69

Customer Support

Technical Assistance

Go to honeywell.com/PSStechnicalsupport to search our knowledge base for a solution or to log into the Technical Support portal.

Product Service and Repair

Honeywell International Inc. provides service for all of its products through service centers throughout the world. Go to sps.honeywell.com and select **Support** to find a service center near you or to get a Return Material Authorization number (RMA #) before returning a product.

Limited Warranty

For warranty information, go to sps.honeywell.com and select **Support > Warranties**.

About This Manual

This user guide provides installation and programming instructions for the HF800 fixed-mount industrial scanner. Product specifications, dimensions and customer support information are also included.

Honeywell recommends using the DataMax[®] Configuration Tool with the HF800 (see page [11](#)).

Model Description

HF800 scanners are available in horizontal and vertical models.

The standard horizontal model addresses most use cases. It provides a laser aimer that helps identify the center of the decoding area.

Vertical models can be mounted in narrow spaces in a vertical direction. The vertical model provides a green LED that helps identify the center of the decoding area.

Both horizontal and vertical models are available in High Definition (HD), Standard Range (SR) or Extended Range (ER) to meet different depth of field requirements.

SKU	Description
HF800HD-1-1H	Horizontal Camera, High Definition, Ethernet
HF800SR-1-1H	Horizontal Camera, Standard Range, Ethernet
HF800ER-1-1H	Horizontal Camera, Extended Range, Ethernet
HF800HD-1-1V	Vertical Camera, High Definition Ethernet
HF800SR-1-1V	Vertical Camera, Standard Range, Ethernet
HF800ER-1-1V	Vertical Camera, Extended Range, Ethernet,

Horizontal Model

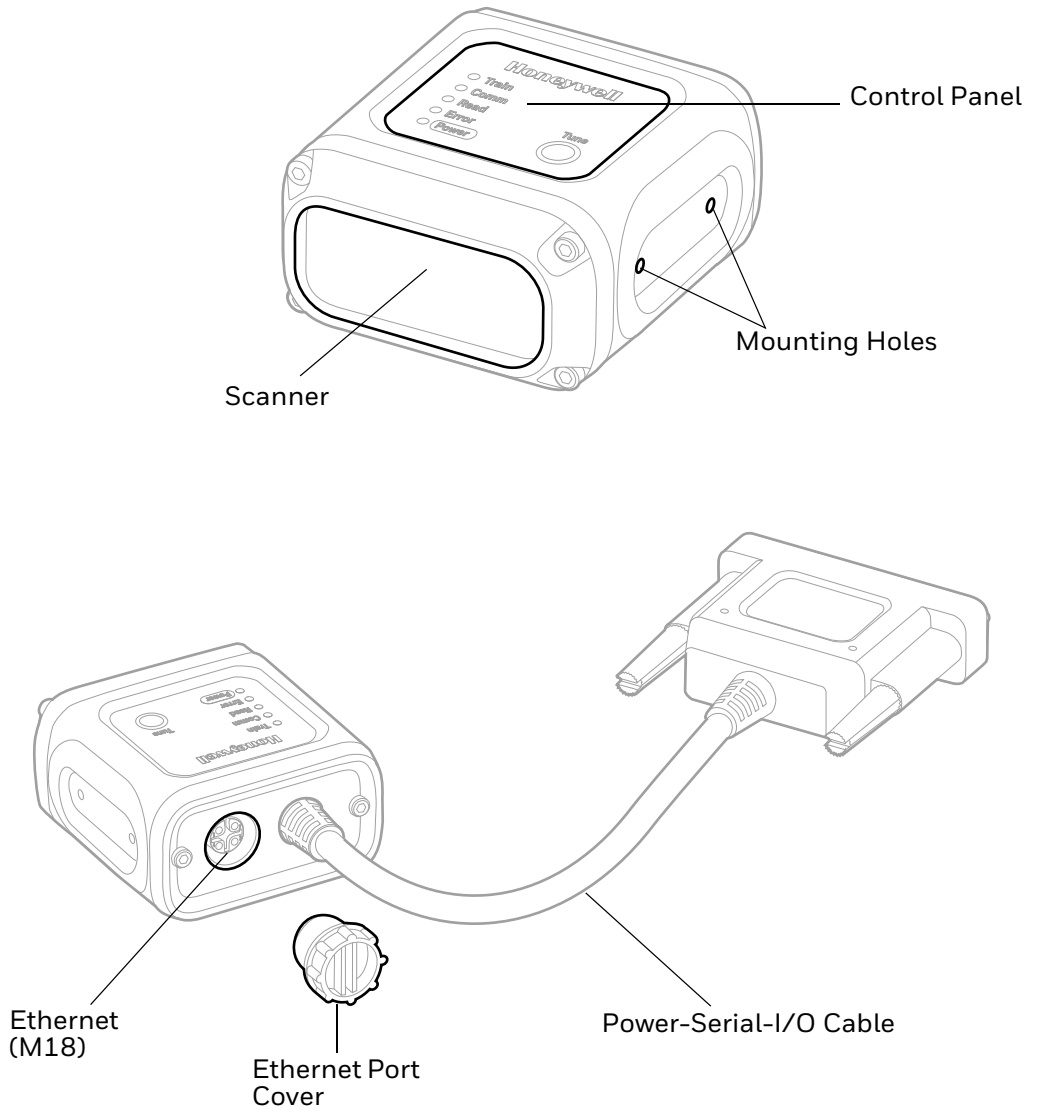

Vertical Model

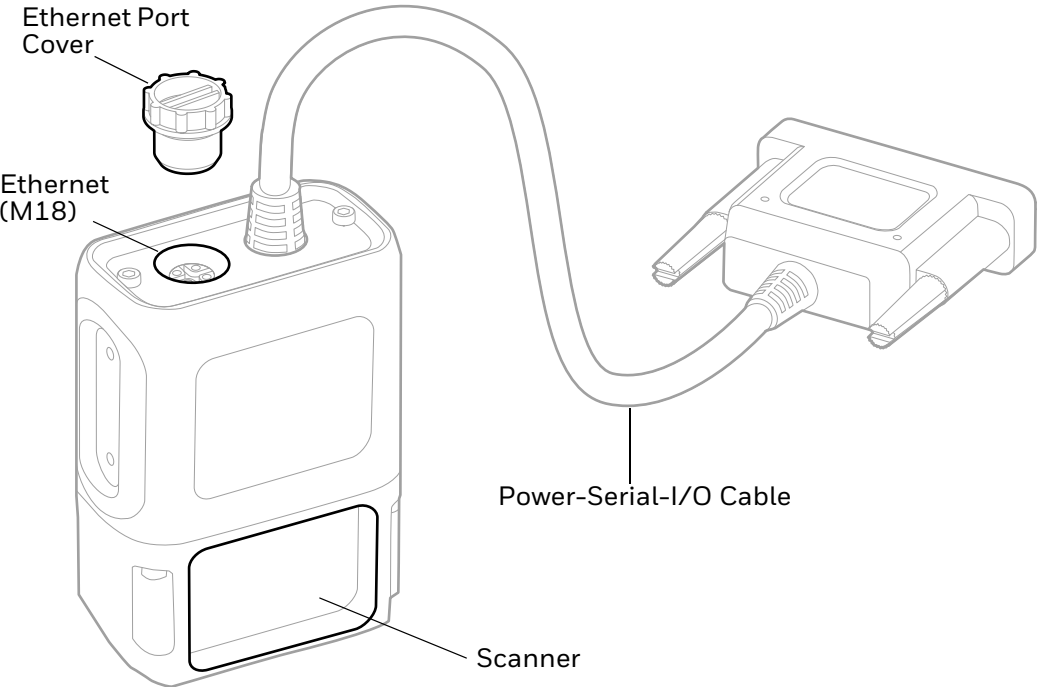
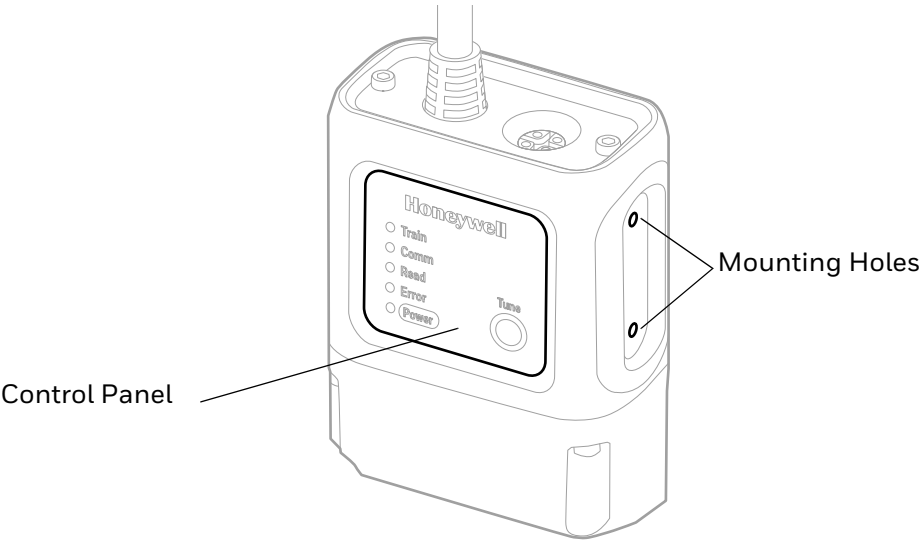

Package Contents

1. HF800 scanner
2. Ethernet port cover

Accessories

For a complete list of accessories, see the HF800 product page at sps.honeywell.com. Contact your local sales representative for ordering information.

Accessory	Part Number
Adapter and Plug Assembly	HCB-PWR-01
I/O + RS232 Cable	50142347-001
I/O + RS232 Discrete Wiring Cable: 5m	50148058-001
I/O + RS232 Discrete Wiring Cable: 10m	50148058-002
I/O + RS485/422 Cable	50144214-001
Ethernet Cable: 2m	50143315-001
Ethernet Cable: 5m	50143315-002
Mounting Bracket Kit (M3 Hole)	50145368-001
Mounting Bracket Kit (M6/8 Hole)	50150441-001
Flat Mounting Bracket Kit (M6/8 Hole)	50150443-001

Mounting Bracket (sold separately)

Use an optional mounting bracket to obtain the optimal position for the HF800 through rotation on the various axes of the scanner.

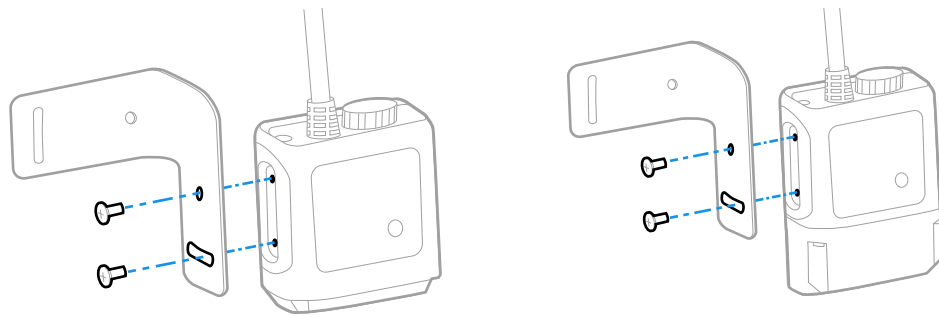

- Mounting screw size: M2.5 (Quantity 6)

Adapter and Plug Assembly

The assembly contains two parts: an adapter and a plug. Assemble the plug and adapter as shown below. The input voltage of the adapter is 100 - 240VAC. Frequency is 50Hz-60Hz. Output voltage is 12.00+/-0.6VDC. Maximum current is 1.25A.

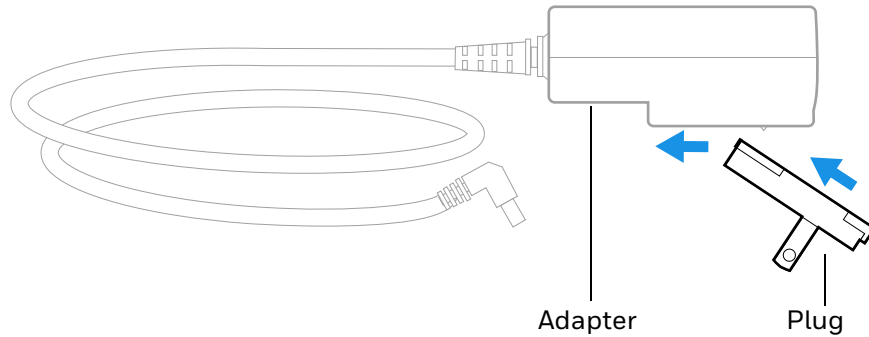

Note: The inside of the DC plug is negative; the outside is positive.

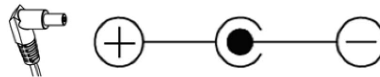

Caution: We recommend the use of Honeywell accessories and power adapters. Use of any non-Honeywell accessories or power adapters may cause damage not covered by the warranty.

Power Requirements

The HF800 scanner supports a wide range of input power, from 10VDC to 30VDC. Maximum power consumption is 5W (internal illumination).

Connect the Device

Note: For illustration purposes, the horizontal model is shown in the instructions below. Connection layouts are the same for both types of models.

Connect with Ethernet

When the scanner is connected via Ethernet, power is supplied through an external 232/485 cable, and data is sent from the on-board Ethernet port of the HF800 to the host.

Note: A power adapter is required if the HF800 is not powered by the connected device.

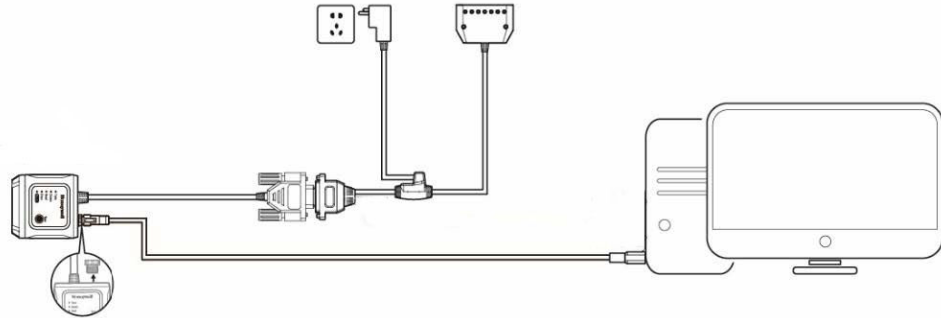

Connect with RS232

In this layout, the data is transmitted to the Host from the HF800 RS232 interface.

Note: Because the I/O connector is combined with the RS232 interface, a power adapter is required if the scanner is not powered by the host device.

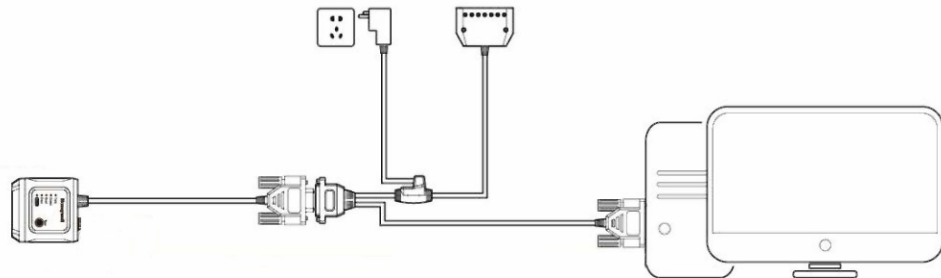

Connect with RS485

When the scanner is connected with a serial point-to-point configuration, data is transmitted to the Host from the HF800 RS485/422 interface.

Note: Because the I/O connector is combined with the RS485/422 interface, a power adapter is required if the scanner is not powered by another device.

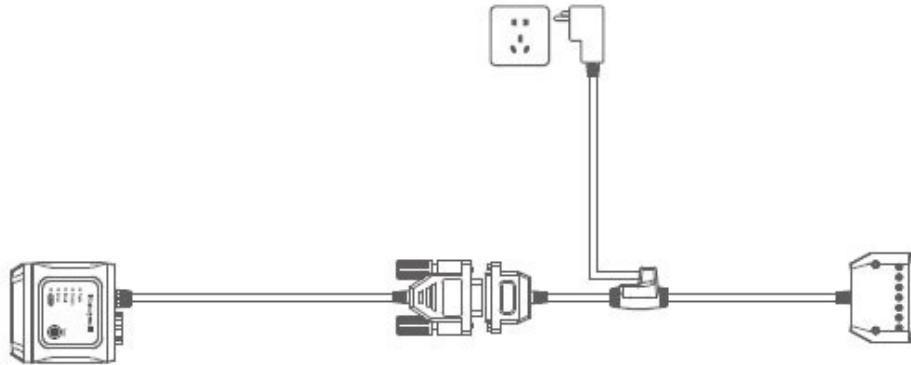

Direct PC Connection

A scanner can be connected directly to a PC using an Ethernet cable. However, additional steps are required.

Note: A power adapter is required.

1. Attach the device and cables as shown in [Connect with Ethernet](#) on page 6, with the Ethernet cable connecting to the computer's Ethernet port.
2. Once the scanner's Power and Comm indicators turn on, scan the following barcode to disable DHCP:



3. Scan the following barcode to reboot the scanner:



4. Set a static IP for the PC:
 - a. Click **Start Menu > Control Panel > Network and Internet > Network and Sharing Center**.
 - b. Click **Change adapter settings**.
 - c. Right-click on the local area network (Ethernet) connection and click **Properties**.

- d. Select **Internet Protocol Version 4 (TCP/IPv4)** and click **Properties**.
- e. Select **Use the following IP address** and enter the IP address, Subnet Mask, Default Gateway, and DNS server.

Note: The scanner default IP address is 192.168.1.110, so make sure your PC IP address and scanner IP address are in the same network segment. For example:

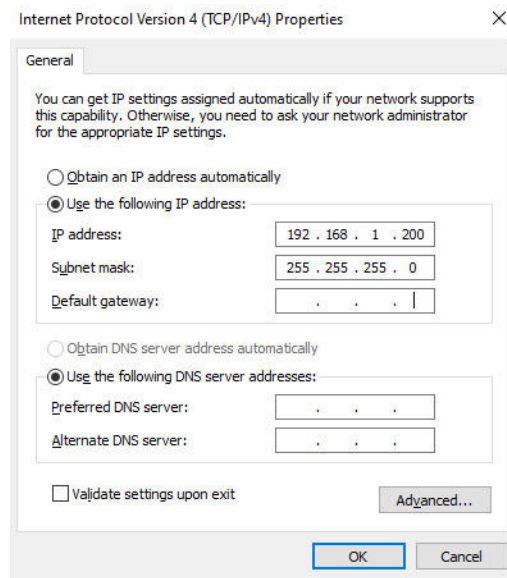

- f. Click **OK**.

Control Panel

The HF800 control panel has five LED indicators to show the scanner status as well as a Tune button for easy configuration.

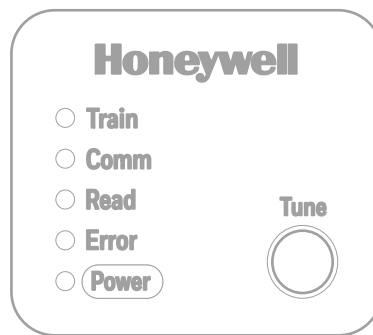

LED	Status	Description
Train	Green/red blinking at 100ms intervals	Indicates that the scanner is in Auto-Train Mode (see next section Tune Button).
	Green/red blinking at 500ms intervals	Notifies the user that the scanner is waiting for confirmation to reset to defaults (see Restore Factory Defaults on page 54).
Comm	Blinking yellow	Indicates that the scanner is receiving active data from the Ethernet line.

LED	Status	Description
Read	Solid green	Confirms a successful barcode read.
Error	Solid red	Indicates an error.
Power	Solid white	Indicates that the scanner is correctly powered.

Tune Button

The Tune button on the HF800 can be used for two purposes:

- Place the scanner in Auto-Train Mode
- or
- Reset scanner defaults (see [page 54](#))

Auto-Train Mode

Auto-training helps to tune imaging parameters and identify barcodes in front of the scanner's field of view automatically. To place the scanner in Auto-Train Mode using the Control Panel, press and hold the Tune button for between 3 to 20 seconds, then release. The Train LED will blink at 100ms intervals during the training process, which lasts several seconds.

If the auto training is successful, the scanner will sound three good read tones. If the training fails, the scanner will sound an error read tone.

You can also use DataMax to perform auto-training (see [page 19](#)).

Honeywell recommends using the DataMax® Configuration Tool with the HF800.

Hardware Requirements

Typical hardware requirements for a DataMax Client PC are:

- 2.00GHz or faster microprocessor
- 1GB RAM
- 2GB hard disk for 64-bit machines; 1GB hard disk for 32-bit machines
- 19" or larger monitor (optimized for 1280x1024 resolution)

Software Requirements

Windows Operating System (32 or 64-bit): Windows XP/7/8/10.

How to Install

1. Download the zip file from the Honeywell Downloads Portal to a PC and extract the files (see page [53](#)).
2. Navigate to the location where you extracted the files, then double-click on DataMaxSetup.exe.
3. Follow the on-screen prompts to install the program.
4. Once the installation wizard completes, click **Finish**.

When the installation is finished, DataMax is added to the Start menu and a desktop shortcut is created.

DataMax User Interface

Double-click the DataMax desktop shortcut to run the program. The DataMax user interface has the following elements:

- A toolbar on the left (see next section).
- A Devices panel where available scanners will be listed (see [Device Discovery](#) on page 13).
- A series of tabs for accessing scanner configuration parameters. These tabs are only accessible when a connected scanner is selected in the Devices panel:
 - Tuning (see page 17)
 - Interface (see page 21)
 - Operation Mode (see page 25)
 - Symbologies (see page 29)
 - Decoding (see page 41)
 - I/O (see page 45)
 - Data (see page 49)
- A status bar on the bottom of the screen (see page 13).

Note: DataMax privileges depend on the user's PC permissions.

Control and Help Toolbar

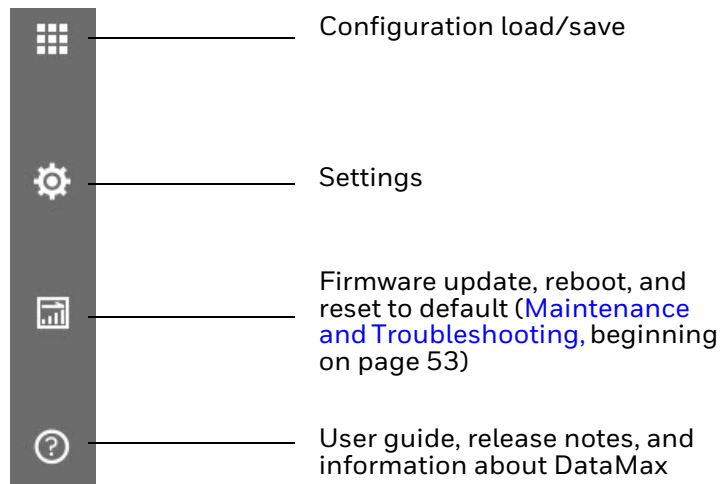

Note: See the HF800 product page at sps.honeywell.com for the most up-to-date user documentation.

Status Bar

The status bar at the bottom of the window displays the DataMax version on the far right. When a scanner is selected in the Devices list, the serial number and device name will also display in the status bar.

Device Discovery

Ethernet

To search for all HF800 scanners connected to the local area network:

1. Click the Search icon  in DataMax.
2. Select **Ethernet**.
3. Click **Search**.

DataMax will automatically search for all connected scanners and list the results in the Devices panel.

EXAMPLE:

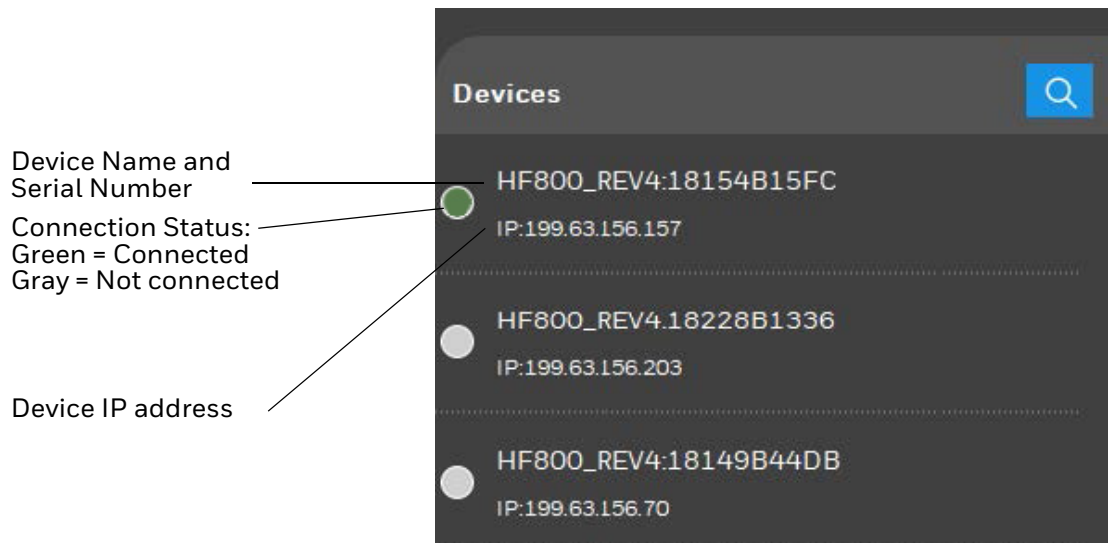

Serial

To search for devices connected directly to the host:

1. Click the Search icon .
2. Select **Serial Port**.
3. Click **Search**.

When DataMax finds a scanner, it will populate the serial port parameters.

4. Click **Connect**.

DataMax will list the connected scanner in the Devices panel.

Connect to a Device

To connect to a previously discovered device, double-click on a scanner name in the Devices list, or right click and select **Connect**.

If DataMax connects successfully, the Connection Status indicator displays green beside the device's name in the Devices panel, and the device's details display in the center panel.

Configurations

DataMax allows you to load and download configuration to or from a PC or device, and to generate configuration barcodes.

Load a Configuration

From a PC

1. Select a connected device.
2. Click .
3. Select **Open Configuration > From Local PC**
4. Select the file path and configuration file name (*.cfg).
5. Click **Save**.
A "Load Configuration Success" dialog displays.
6. Click **OK**.

From a Device

Opening a configuration from a device will load the settings from a connected device manually. For example, if the settings of the device have been changed through another tool after the device was connected to DataMax, loading the settings manually will re-synchronize the settings in DataMax.

1. Select a connected device.
2. Click .
3. Select **Open Configuration > From Device**.

A “Load Configuration Success” dialog displays.

4. Click **OK**.

Save a Configuration

To a PC

1. Select a connected device.
2. Click  in the toolbar.
3. Select **Save Configuration > To PC**.
4. Select a file path and a file name.
5. Click **Save**.
A “Save Success” dialog displays.
6. Click **OK**.

To a Device

1. Select a connected device.
2. Click  in the toolbar.
3. Select **Save Configuration > To Device**,
A “Save Success” dialog displays.
4. Click **OK**.

Settings

Click  in the toolbar to access the Settings menu.

Setting	Description
Language	Choose from a list of available languages.
Logging	Enable or disable information and error logs.
System Setting	Specify where you would like DataMax to save log files and images.

Use the Tuning function of DataMax to monitor the images captured by the device and to tune the scanner to acquire better images with proper exposure and gain parameters. You can also use the Tuning page to monitor decoded and output results. In addition, you can use the Auto Train function to automatically tune parameters of the scanner.

To access the Tuning page:

- Open DataMax and connect to a device (see page 13).

The **Tuning** page is the default DataMax page.

Live View

Live View displays images captured by a connected device. Live View is turned off by default, and the window will be blank.

Click  to enable Live View. If the scanner is configured correctly, the images captured by the device display in the window.

While Live View is enabled the button will change to . Click the button again to turn Live View off.

Crop

To reduce search and decode times, you can crop the Live View search region from the whole field of view to a smaller area.

1. Click  on the top left corner of the Live View panel.
2. Position the cursor above the Live View window.
3. Press and hold the left mouse button to set the top left position then drag the cursor to draw a red rectangle.

As you draw, the dimensions of the selected area display on screen.

4. Release the mouse button.

Now the scanner will only decode barcodes within this smaller window.

To turn Image Cropping Off, click .

Save

To save the image displayed in the Live View panel:

1. Click .
2. Choose a location.
3. Click **Save**.

Log View

Log View is located beneath the Live View panel. There are two tabs:

- **Logger:** Displays the barcode time stamp, type and contents.
- **Output:** Displays the output, including any prefix, suffix, or added strings.

Save

To save either Logger or Output results:

1. Right-click in the Log View.
2. Click **Save to file**.
3. Choose a location.
4. Click **Save**.

The content of that tab will be saved to a .txt file.

Clear

To clear the information in the active Log View:

1. Right-click in the Log View.
2. Select **Clear**.

Statistics

The Statistics panel to the right of the Tuning page shows all the current decoding counters. Use this panel to monitor the decoding rate and average decode times.

Click **Reset** to set all the counters to zero.

Auto-Train Tuning

Auto-Train helps tune the imaging parameters and automatically identify the barcodes in front of the scanner's field of view, which can reduce distribution time.

1. Choose **Default** or **Customize**. With Customize enabled, you can specify the minimum and maximum value for exposure time as well as the maximum gain.
2. Click **Tune**.

Note: Turn Live View On to monitor the learning process.

After several seconds, if the Auto Train is successful the scanner beeps three times and a dialog displays.

If the Auto Train fails, the scanner sounds an error beep and a dialog displays.

3. Click **OK**.

Image Setup

Use this panel to configure image settings such as exposure, gain and bank setting.

Setting	Description	Default
Bank Setting	Establish a set of configuration parameters (see next section Bank Setting).	
Recording Image	Select to save a .bmp of every successfully read barcode. The save directory is defined in DataMax Settings (see page 15). Saving all images requires a lot of storage space.	Disable
Recording No Read Image	Select to save a .bmp of every unsuccessfully read image. The save directory is defined in DataMax Settings (see page 15). Saving all images requires a lot of storage space.	Disable
Exposure Mode	Select whether the scanner's Exposure Mode is automatic or manually configured. In Auto Mode , the scanner will adjust the exposure time and the gain automatically for the images it captures from the sensor. To use specific exposure time and gain settings, select Fixed Mode .	Auto Mode
Exposure	Manually enter the desired exposure time in milliseconds when the Exposure Mode is set to Fixed Mode. In Auto Mode this field is unavailable.	2500
Gain	Manually enter the desired gain when the Exposure Mode is set to Fixed Mode. In Auto Mode this field is unavailable.	4

Bank Setting

DataMax supports up to eight banks of configuration settings. You can specify exposure time and gain for each bank and choose whether to enable or disable it.

If more than one bank is enabled, the scanner will switch between different bank settings while reading until a barcode is scanned successfully or a timeout occurs.

1. Select **Fixed** Exposure Mode.
2. Click **Bank Setting**.
3. Enter the desired bank settings.

When each specific bank is enabled, the related parameters will take effect immediately.

4. Close the Bank window.

Aimer & Light

In the Aimer & Light panel, you can enable or disable the scanner's internal illumination as well as the laser/LED aimer.

Charts Panel

When a scanner is connected and working and Live View is enabled, the Charts panel demonstrates the statical value of decode time and good read rate.

This chapter explains how to set up network or serial communications. For instructions on how to correctly connect scanner cables, see page 5.

Network Setup

1. Open DataMax and connect a device via Ethernet (see page 13).
2. Right-click on the scanner in the list of devices and select **Network Setting**.
3. Enable **DHCP**. The device will retrieve the IP address subnet address and gateway automatically from the DHCP server. (When DHCP is enabled, the other fields will be unavailable.)

To manually set up static IP address, subnet and gateway, disable DHCP.

4. Click **OK** and your settings will be saved to the device.
5. Reboot your device to complete the network setup.

Network Grouping

HF800 supports network grouping, with up to 8 scanners in a group. Network grouping supports two modes: Synchronize or Passthrough.

In Synchronize Mode, you can use one trigger source to trigger all the HF800 scanners in the group. The master device will receive data from the slave devices, process all of the data (data format, sequence) and transmit the overall data through the master's interface.

Typical Synchronize Mode Application:

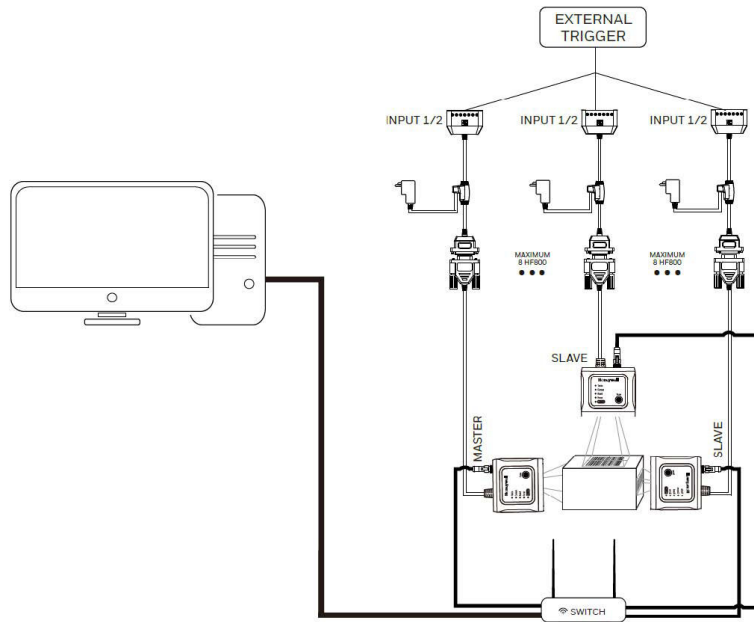

In Passthrough Mode, all the HF800 units can be triggered by one source or be triggered separately. The master will act as a repeater and transmit all of the data from the slave devices without processing through the master device's interface.

Typical Passthrough Mode Application:

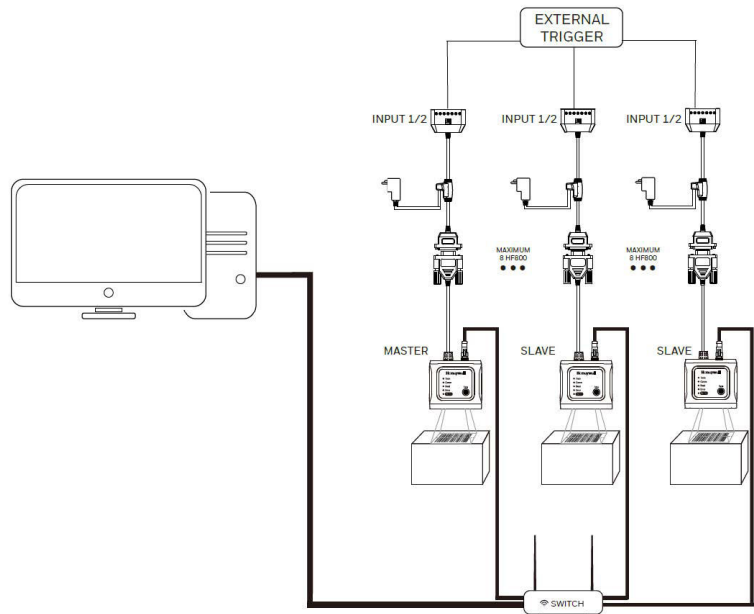

Set Up a Network Group

1. Open DataMax and connect the scanners to be included in the network group.
2. Select the scanner to act as master in the **Devices** panel.

3. Select the **Interface** tab and then the **Network** subtab.
4. Select **Master** next to Network Role.
5. Select an Internal Work Mode: **Synchronize** or **Passthrough**.
6. Click **OK**.

Note: Ensure that master and slave devices share the same symbology settings. If the slave device decodes and transmits a symbology to the master device that the master does not support, the master device will ignore that symbology.

View Existing Network Grouping

1. Select a scanner in the **Devices** panel.
2. Select the **Interface** tab and then the **Network** subtab.

If the current Network Role for that device is set to **Master**, DataMax will list current grouping information, and you will have the option to add additional slaves.

If the current Network Role for that device is set to **Slave**, all other options will be grayed out.

To remove a slave, click **Delete** next to the device in the list.

Serial Interface Setup

The Serial interface is used when connecting to the serial port of a PC or terminal. Select the **Interface** tab in DataMax and click the **Serial** subtab.

Setting	Description	Default
Output Port	Type of serial port: RS232 or RS485	
Baudrate	Sends the data from the scanner to the terminal at the specified rate. The host terminal must be set to the same baud rate as the scanner.	115200
Word Format	<p>Data Bits sets the word length to 7 or 8 bits of data per character. If an application requires only ASCII Hex characters 0 through 7F decimal (text, digits, and punctuation), select 7 data bits. For applications that require use of the full ASCII set, select 8 data bits per character.</p> <p>Stop Bits sets the stop bits at 1 or 2.</p> <p>Parity provides a means of checking character bit patterns for validity.</p>	8 Data Bits 1 Stop Bit No Parity
XON/XOFF Software Flow Control	Standard ASCII control characters can be used to tell the scanner to start sending data (XON/XOFF On) or to stop sending data (XON/XOFF Off). When the host sends the XOFF character (DC3, hex 13) to the scanner, data transmission stops. To resume transmission, the host sends the XON character (DC1, hex 11). Data transmission continues where it left off when XOFF was sent.	XON/XOFF Off

Setting	Description	Default
ACK/NAK Software Flow Control	After transmitting data, the scanner waits for an ACK character (hex 06) or an NAK character (hex 15) response from the host. If ACK is received, the communications cycle is completed, and the scanner looks for more barcodes. If NAK is received, the last set of barcode data is retransmitted, and the scanner waits for ACK/NCK again.	Disabled
RS232 Time-out (ms)	When using Flow Control with Timeout, you must program the length of the delay from 1-5100 milliseconds that you want to wait for CTS from the host.	Disabled
RTS/CTS Hardware Flow Control	<p>Allows control of data transmission from the scanner using software commands from the host device.</p> <ul style="list-style-type: none"> • RTS/CTS off No data flow control is used. • Flow Control, No Timeout The scanner asserts RTS when it has data to send and will wait indefinitely for CTS to be asserted by the host. • Two-Direction Flow Control The scanner asserts RTS when it is OK for the host to transmit. The host asserts CTS when it is OK for the devices to transmit. • Flow Control with Timeout The scanner asserts RTS when it has data to send and waits for a delay (see RS232 Time-out) for CTS to be asserted by the host. If the delay time expires and CTS is not asserted, the device transmit buffer is cleared and scanning may resume. 	RTS/CTS off

DataMax provides four operation modes:

- Internal Trigger
- External Trigger
- Presentation
- Streaming Presentation (Default)

To set an operation mode:

1. Select a connected device (see page [13](#)).
2. Click the **Operation Mode** tab.
3. Select an option from the **Operation Mode** drop-down list.

The scanner will enter that mode immediately. Available options will differ based on the mode selected (see below).

Internal Trigger Mode

When set to Internal Trigger Mode, the scanner will trigger itself within a user-specified time interval infinitely. (For instructions on setting the time interval, see [Read Timeout](#) on page 41.)

External Trigger Mode

In External Trigger Mode, the scanner will wait for an external trigger signal. This signal can be a pulse or a latched electrical level. When the scanner detects this signal, it will try to search for barcodes immediately.

The scanner can also be triggered by receiving the command from the host through serial or network interface. To trigger the scanner from DataMax, click **Trigger On**.

External Trigger Mode Options

Setting	Description	Default
Working Mode	<ul style="list-style-type: none"> • OneShot The scanner will only capture one image and try to decode this image when it detects an external trigger signal. • Burst The scanner will start to search for barcodes when it detects an external trigger signal and will remain in this state no matter whether or not the external trigger signal is removed until a barcode is decoded or the timeout occurs. • Continuous-Sync When the scanner is in Continuous-Sync Mode, keep the external trigger signal pulled once triggered. If the user stops the external trigger signal after being triggered, the scanner will cancel reading immediately. If the scanner has read the barcodes or the timeout occurs, the scanner will also trigger off although the trigger signal is still on. • Continuous-ASync The scanner will be triggered when it detects an external electrical impulse or level. The scanner will keep the trigger state even if the external signal is pulled out. The scanner will trigger off until it decodes a barcodes or the timeout occurs. 	Continuous ASync
Trigger Time (Burst Mode only)	Set a Trigger Time. When this value is larger than 1, the scanner will repeat the barcode reading activity for the specific time. In each reading cycle, the scanner will acquire one image and try to search the barcodes contained in it. You can also set the duration for each reading cycle using the Read Timeout parameter (see page 41).	2
External Trigger Delay	Set a trigger delay in milliseconds from zero to 10,000. If the delay duration is larger than zero, the scanner will delay for the user-specified time value (in milliseconds) then trigger the scanner. If the delay duration is equal to zero, the scanner will be triggered immediately.	500
Trigger Command String	Customize the trigger string.	TRIGGER
Untrigger Command String	Customize the untrigger string.	UNTRIG
Image Buffer Depth	Set a buffer depth between 1 and 10.	1

Note: You can use custom Trigger and Untrigger strings. However, do not use the same string in both fields.

Trigger Through Remote Commands

The scanner can also be triggered by sending a specified ASCII command via serial or network connection:

Activate: SYN T CR (ASCII 22 84 13)

Deactivate: SYN U CR (ASCII 22 85 13)

The device scans until a barcode is read, the deactivate command is sent, or the timeout has been reached.

To customize the TCP port for sending trigger command through a network, click the **Interface** tab, select the **Network** subtab, and modify the port value. *Default = 55256.*

Presentation Mode

Presentation Mode uses ambient light and scanner illumination to detect barcodes. When in Presentation Mode, the LEDs remains dim until a barcode is presented to the scanner, then the LEDs light up and the aimer turns on so that the scanner can read the code.

Note: *If the light level in the room is not high enough, Presentation Mode may not work properly. If room lighting is not sufficient, auxiliary lighting may be used to improve scanning performance.*

Presentation Mode Options

Setting	Description	Default
Idle Illumination Level	Sets the brightness of the scanner's internal illumination when the device is not actively scanning?	Low
LED Behavior After Decode	The LED aimer dims 30 seconds after a barcode is decoded. Disable this feature if you wish to dim the LED aimer immediately after a barcode is decoded?	Enabled
Object Detect Sensitivity	Sets the scanner's sensitivity to barcode presentation (1-3).	1
Idle State Protect Duration	The minimum duration the scanner will stay in an idle state.	1000

Streaming Presentation Mode

In Streaming Presentation Mode, the scanner remains on all the time to continuously search for barcodes.

To configure the scanner's illumination and aimer to be on or off, use the Tuning page (see page [20](#)).

SYMBOLOLOGIES

You can use DataMax to enable or disable symbologies individually or by group, as well as to control features specific to each barcode type.

The HF800 supports the following symbologies:

- Australian Post
- Maxicode
- Codabar
- Codablock A
- Codablock F
- Code 11
- Code 39
- Code 93
- Code 128
- DataMatrix
- Dot Code
- EAN-8
- EAN-13
- GS1-128
- GS1 DataBar
- GS1 DataBar Limited
- GS1 DataBar Expanded
- HanXin (Chinese Sensible)
- Intelligent Mail
- Interleaved 2 of 5
- Japanese Post
- KIX Post
- Maxicode
- MicroPDF
- MSI
- PDF417
- Planet Code
- Postnet
- Postnet with B and B' Fields
- QR Code
- UPC-A
- UPC-E

Message Length Description

Some barcode symbologies require valid reading lengths. If the data length of the scanned barcode doesn't match the specific reading length, the scanner will sound an error tone. You may wish to set the same value for minimum and maximum length to force the scanner to read fixed-length barcode data in order to reduce the chances of a misread.

EXAMPLE: Decode only those barcodes with a count of 9-20 characters.

Min length = 09, Max length = 20

EXAMPLE: Decode only those barcodes with a count of 15 characters.

Min length = 15, Max length = 15

Symbologies Tab

In DataMax, use the **Symbologies** tab to enable or disable symbologies and set associated parameters.

- 2D (see page [31](#))
- Linear (see page [32](#))
- Stacked Linear (see page [39](#))
- Postal Codes (see page [39](#))

Enable Symbologies

1. Select a connected device (see page [13](#)).
2. Click the **Symbologies** tab.
3. Choose a category (2D, Linear, Stacked Linear or Postal Code).
4. Click **Check All** at the top of the list to enable all symbologies within that group, or enable individual symbologies by clicking the checkbox next to the symbology name(s).
5. Select a symbology to set parameters.

Disable Symbologies

1. Open DataMax and connect a device.
2. Click the **Symbologies** tab.
3. Choose a category.
4. If **Check All** is enabled at the top of the list, click on it again to disable all symbologies within that category.
Or click the checkbox next to an enabled symbology to disable it.

2D Symbologies

Aztec

Setting	Description	Default
Minimum Length	Output the decode result when the symbology length is equal to or larger than the minimum length.	1
Maximum Length	Output the decode result when the symbology length is equal to or shorter than the maximum length.	3832
Append Mode	Allows the HF800 to append the data from several HF800 barcodes together before transmitting them to the host computer. When the HF800 encounters an Aztec barcode with the append trigger character(s), it buffers the number of Aztec barcodes determined by information encoded in those barcodes. Once the proper number of codes is reached, the data is output in the order specified in the barcodes.	1
Strip Append Information	When enabled, this mode strips off the append information from the barcode. Details about append information can be found in the Aztec ISO specification. For debug purposes, this mode allows the append information to be output with the data.	Enabled

Maxicode

Setting	Description	Default
Minimum Length	Output the decode result when the symbology length is equal to or larger than the minimum length.	1
Maximum Length	Output the decode result when the symbology length is equal to or shorter than the maximum length.	150

HanXin

Setting	Description	Default
Minimum Length	Output the decode result when the symbology length is equal to or larger than the minimum length.	1
Maximum Length	Output the decode result when the symbology length is equal to or shorter than the maximum length.	7833

DataMatrix

Setting	Description	Default
Minimum Length	Output the decode result when the symbology length is equal to or larger than the minimum length.	1
Maximum Length	Output the decode result when the symbology length is equal to or shorter than the maximum length.	3116

QR Code

Setting	Description	Default
Minimum Length	Output the decode result when the symbology length is equal to or larger than the minimum length.	1
Maximum Length	Output the decode result when the symbology length is equal to or shorter than the maximum length.	7089
Append Mode	Allows the HF800 to append the data from several QR HF800 barcodes together before transmitting them to the host computer. When the HF800 encounters a QR Code barcode with the append trigger character(s), it buffers the number of QR Code barcodes determined by information encoded in those barcodes. Once the proper number of codes is reached, the data is output in the order specified in the barcodes.	1

Dot Code

Setting	Description	Default
Minimum Length	Output the decode result when the symbology length is equal to or larger than the minimum length.	1
Maximum Length	Output the decode result when the symbology length is equal to or shorter than the maximum length.	2400

Linear Symbologies

Code 11

Setting	Description	Default
Redundant Times	Output decoding results only when identical barcode information is obtained within the specified time.	0
Minimum Length	Output the decode result when the symbology length is equal to or larger than the minimum length.	4
Maximum Length	Output the decode result when the symbology length is equal to or shorter than the maximum length.	80
Check Digits	Determines whether 1 or 2 check digits are required with Code 11 barcodes.	1

Code 128

Setting	Description	Default
Redundant Times	Output decoding results only when identical barcode information is obtained within the specified time.	0
Minimum Length	Output the decode result when the symbology length is equal to or larger than the minimum length.	0
Maximum Length	Output the decode result when the symbology length is equal to or shorter than the maximum length.	80

Setting	Description	Default
Append Mode	Allows the HF800 to append the data from several Code 128 barcodes together before transmitting them to the host computer. When the HF800 encounters a Code 128 barcode with the append trigger character(s), it buffers Code 128 barcodes until it reads a Code 128 barcode that does not have the append trigger. The data is then transmitted in the order in which the barcodes were read (FIFO).	Enabled
Function Code Transmit	If enabled, the hex value for the function character will be sent out in the data stream. For 128 Function 1, Function 2, Function 3, Function 4 all cause special events to happen per the ISO Specification. If enabled, this setting causes Function 1, 2 and 4 to be ignored and the raw data output. This does not apply to function 3 as that signifies a menu command in code 128.	Disabled
ISBT Decoding	The ISBT 128 Application Specification describes: 1) the critical data elements for labeling blood products; 2) the current recommendation to use Code 128 due to its high degree of security and its space-efficient design; 3) a variation of Code 128 that supports concatenation of neighboring symbols; and 4) the standard layout for barcodes on a blood product label.	Disabled

Code 39

Setting	Description	Default
Redundant Times	Output decoding results only when identical barcode information is obtained within the specified time.	0
Minimum Length	Output the decode result when the symbology length is equal to or larger than the minimum length.	0
Maximum Length	Output the decode result when the symbology length is equal to or shorter than the maximum length.	48
Transmit Start/Stop Characters	Start/Stop characters identify the leading and trailing ends of the barcode.	Disabled
Check Character	<ul style="list-style-type: none"> No check The HF800 reads and transmits barcode data with or without a check character. Validate not transmit The scanner only reads Code 39 barcodes printed with a check character but does not transmit the check character with the scanned data. Validate & Transmit The scanner only reads Code 39 barcodes printed with a check character and transmits this character at the end of the scanned data. 	No check
Append Mode	Allows the HF800 to append the data from several Code 39 barcodes together before transmitting them to the host computer. When the HF800 encounters a Code 39 barcode with the append trigger character(s), it buffers Code 39 barcodes until it reads a Code 39 barcode that does not have the append trigger. The data is then transmitted in the order in which the barcodes were read (FIFO).	Disabled

Setting	Description	Default
Full ASCII Mode	When enabled, certain character pairs within the barcode symbol are interpreted as a single character. For example: \$V is decoded as the ASCII character SYN, and /C is decoded as the ASCII character #. (See ASCII table below.)	Disabled
Code 32 (PARAF) Decoding	Code 32 Pharmaceutical is a form of the Code 39 symbology used by Italian pharmacies. This symbology is also known as PARAF.	Disabled

ASCII Table

Full ASCII Table							
NUL %U	DLE\$P	SP SPACE	0 0	@ %V	P P	' %W	p +P
SOH \$A	DC1 \$Q	! /A	1 1	A A	Q Q	a +A	q +Q
STX \$B	DC2 \$R	" /B	2 2	B B	R R	b +B	r +R
ETX \$C	DC3 \$S	# /C	3 3	C C	S S	c +C	s +S
EOT \$D	DC4 \$T	\$ /D	4 4	D D	T T	d +D	t +T
ENQ \$E	NAK \$U	% /E	5 5	E E	U U	e +E	u +U
ACK \$F	SYN \$V	& /F	6 6	F F	V V	f +F	v +V
BEL \$G	ETB \$W	' /G	7 7	G G	W W	g +G	w +W
BS \$H	CAN \$X	(/H	8 8	H H	X X	h +H	x +X
HT \$I	EM \$Y) /I	9 9	I I	Y Y	i +I	y +Y
LF \$J	SUB \$Z	* /J	: /Z	J J	Z Z	j +J	z +Z
VT \$K	ESC %A	+ /K	; %F	K K	[%K	k +K	{ %P
FF \$L	FS %B	, /L	< %G	L L	\ %L	l +L	%Q
CR \$M	GS %C	--	= %H	M M] %M	m +M	} %R
SO \$N	RS %D	..	> %I	N N	^ %N	n +N	~ %S
SI \$O	US %E	/ /O	? %J	O O	_ %O	o +O	DEL

Codabar

Setting	Description	Default
Redundant Times	Output decoding results only when identical barcode information is obtained within the specified time.	0
Minimum Length	Output the decode result when the symbology length is equal to or larger than the minimum length.	4
Maximum Length	Output the decode result when the symbology length is equal to or shorter than the maximum length.	60
Transmit Start/Stop Characters	Start/Stop characters identify the leading and trailing ends of the barcode.	Disabled

Setting	Description	Default
Check Character	<p>Codabar check characters are created using different “modulos.” You can program the HF800 to read only Codabar barcodes with Modulo 16 check characters.</p> <ul style="list-style-type: none"> • No check The scanner reads and transmits barcode data with or without a check character. • Validate not transmit The scanner only reads Codabar barcodes printed with a check character but does not transmit the check character with the scanned data. • Validate & Transmit The scanner only reads Codabar barcodes printed with a check character and transmits this character at the end of the scanned data. 	No check

Code 93

Setting	Description	Default
Redundant Times	Output decoding results only when identical barcode information is obtained within the specified time.	0
Minimum Length	Output the decode result when the symbology length is equal to or larger than the minimum length.	2
Maximum Length	Output the decode result when the symbology length is equal to or shorter than the maximum length.	60
Append Mode	Allows the HF800 to append the data from several Code 93 barcodes together before transmitting them to the host computer. When this function is enabled, the HF800 stores those Code 93 barcodes that start with a space (excluding the start and stop symbols) and does not immediately transmit the data. The HF800 stores the data in the order in which the barcodes are read, deleting the first space from each. The HF800 transmits the appended data when it reads a Code 93 barcode that starts with a character other than a space.	Disabled

EAN-13

Setting	Description	Default
Redundant Times	Output decoding results only when identical barcode information is obtained within the specified time.	0
Check Digit Transmit	Specifies whether the check digit should be transmitted at the end of the scanned data.	Enabled
2 Digit Addenda	Adds 2 digits to the end of all scanned EAN-13 data.	Disabled
5 Digit Addenda	Adds 5 digits to the end of all scanned EAN-13 data.	Disabled
Addenda Required	When Addenda Required is enabled, the HF800 only reads EAN-13 barcodes that have addenda	Disabled
Addenda Separator	When this feature is enabled, there will be a space between the data from the barcode and the data from the addenda. When it is disabled, there is no space.	Enabled

Setting	Description	Default
ISBN on	When ISBN On is enabled, EAN-13 Bookland symbols are translated into their equivalent ISBN number format.	Disabled

EAN-8

Setting	Description	Default
Redundant Times	Output decoding results only when identical barcode information is obtained within the specified time.	0
Check Digit Transmit	Specifies whether the check digit should be transmitted at the end of the scanned data.	Enabled
2 Digit Addenda	Adds 2 digits to the end of all scanned EAN-8 data.	Disabled
5 Digit Addenda	Adds 5 digits to the end of all scanned EAN-8 data.	Disabled
Addenda Required	When Addenda Required is enabled, the HF800 only reads EAN-8 barcodes that have addenda	Disabled
Addenda Separator	When this feature is enabled, there will be a space between the data from the barcode and the data from the addenda. When it is disabled, there is no space.	Enabled

GS1-128

Setting	Description	Default
Minimum Length	Output the decode result when the symbology length is equal to or larger than the minimum length.	0
Maximum Length	Output the decode result when the symbology length is equal to or shorter than the maximum length.	80

GS1 DataBar

Setting	Description	Default
Minimum Length	Output the decode result when the symbology length is equal to or larger than the minimum length.	4
Maximum Length	Output the decode result when the symbology length is equal to or shorter than the maximum length.	74

GS1 DataBar Limited

Setting	Description	Default
Minimum Length	Output the decode result when the symbology length is equal to or larger than the minimum length.	4
Maximum Length	Output the decode result when the symbology length is equal to or shorter than the maximum length.	74

GS1 DataBar Expanded

Setting	Description	Default
Minimum Length	Output the decode result when the symbology length is equal to or larger than the minimum length.	4
Maximum Length	Output the decode result when the symbology length is equal to or shorter than the maximum length.	74

Interleaved 2 of 5

Setting	Description	Default
Minimum Length	Output the decode result when the symbology length is equal to or larger than the minimum length.	4
Maximum Length	Output the decode result when the symbology length is equal to or shorter than the maximum length.	80
Check Digit	<ul style="list-style-type: none"> • No check The scanner reads and transmits barcode data with or without a check digit. • Validate, but Don't Transmit The scanner only reads Interleaved 2 of 5 barcodes printed with a check digit but does not transmit the check digit with the scanned data. • Validate & Transmit The scanner only reads Interleaved 2 of 5 barcodes printed with a check digit and transmits this digit at the end of the scanned data. 	No check

MSI

Setting	Description	Default
Minimum Length	Output the decode result when the symbology length is equal to or larger than the minimum length.	4
Maximum Length	Output the decode result when the symbology length is equal to or shorter than the maximum length.	48
Check Character	<p>Different types of check characters are used with MSI barcodes. You can program the HF800 to read MSI barcodes with Type 10 check characters.</p> <ul style="list-style-type: none"> • Validate Type 10/11 and Transmit The scanner only reads MSI barcodes printed with the specified type of check character(s) and transmits the character(s) at the end of the scanned data. • Validate Type 10/11, but Don't Transmit The scanner only reads MSI barcodes printed with the specified type of check character(s) but does not transmit the check character(s) with the scanned data. • Disabled 	Validate Type 10 but Don't Transmit

UPC-A

Setting	Description	Default
Redundant Times	Output decoding results only when identical barcode information is obtained within the specified time.	0
Check Digit Transmit	Specifies whether the check digit should be transmitted at the end of the scanned data.	Enabled
Number System Digit Transmit	The numeric system digit of a UPC symbol is normally transmitted at the beginning of the scanned data. Disabling this function prevents the digit being transmitted.	Enabled
2 Digit Addenda	Adds 2 digits to the end of all scanned UPC-A data.	Disabled
5 Digit Addenda	Adds 5 digits to the end of all scanned UPC-A data.	Disabled
Addenda Required	When Addenda Required is enabled, the HF800 only reads UPC-A barcodes that have addenda	Disabled
Addenda Separator	When this feature is enabled, there will be a space between the data from the barcode and the data from the addenda. When it is disabled, there is no space.	Enabled

UPC-E

Setting	Description	Default
Redundant Times	Output decoding results only when identical barcode information is obtained within the specified time.	0
E0 Decoding	Most UPC barcodes have a leading 0 digit system. For these codes, use UPC-E0.	Enabled
E1 Decoding	Enable this feature if you need to read codes with a leading 1 digit system.	Disabled
E Expand	UPC-E Expand expands the UPC-E code to the 12 digit, UPC-A format.	Disabled
E Check Digit Transmit	Specifies whether the check digit should be transmitted at the end of the scanned data.	Enabled
UPC-E0 Leading Zero	Allows the transmission of a leading zero (0) at the beginning of scanned data.	Enabled
2 Digit Addenda	Adds 2 digits to the end of all scanned UPC-E data.	Disabled
5 Digit Addenda	Adds 5 digits to the end of all scanned UPC-E data.	Disabled
Addenda Required	When Addenda Required is enabled, the HF800 only reads UPC-E barcodes that have addenda.	Disabled
Addenda Separator	When this feature is enabled, there will be a space between the data from the barcode and the data from the addenda. When it is disabled, there is no space.	Enabled

Stacked Linear Symbologies

PDF417

Setting	Description	Default
Minimum Length	Output the decode result when the symbology length is equal to or larger than the minimum length.	1
Maximum Length	Output the decode result when the symbology length is equal to or shorter than the maximum length.	2750
Macro PDF417	MacroPDF417 is an implementation of PDF417 capable of encoding very large amounts of data into multiple PDF417 barcodes. When this selection is enabled, these multiple barcodes are assembled into a single data string.	Enabled

MicroPDF

Setting	Description	Default
Minimum Length	Output the decode result when the symbology length is equal to or larger than the minimum length.	1
Maximum Length	Output the decode result when the symbology length is equal to or shorter than the maximum length.	366

Codablock A

Setting	Description	Default
Minimum Length	Output the decode result when the symbology length is equal to or larger than the minimum length.	0
Maximum Length	Output the decode result when the symbology length is equal to or shorter than the maximum length.	600

Codablock F

Setting	Description	Default
Minimum Length	Output the decode result when the symbology length is equal to or larger than the minimum length.	0
Maximum Length	Output the decode result when the symbology length is equal to or shorter than the maximum length.	2048

Postal Codes - 2D

DataMax supports the following 2D postal codes:

- Australian Post
- Intelligent Mail

- Japanese Post
- KIX Post
- Planet Code
- Postnet
- Postnet with B and B' Fields

Australia Post, Planet Code, and Postnet have optional parameters. By default, Postal Codes are turned off.

Australian Post

Setting	Description	Default
Bar Output	Controls what interpretation is applied to customer fields in Australian 4-State symbols. (Refer to the Australian Post Specification Tables.) <ul style="list-style-type: none"> • Off Feature is disabled. • Numeric N Table The field is interpreted as numeric data using the N Table. • Alphanumeric C Table The field is interpreted as alphanumeric data using the C Table. • Combination C and N Tables The field is interpreted using either the C or N Tables. 	Off

Planet Code

Setting	Description	Default
Check Digit Transmit	Specifies whether the check digit should be transmitted at the end of the scanned data.	Disabled

Postnet

Setting	Description	Default
Check Digit Transmit	Specifies whether the check digit should be transmitted at the end of the scanned data.	Disabled

DECODER CONFIGURATION

This chapter explains how to configure scanner parameters using the **Decoding** tab in DataMax.

1. Open DataMax and connect a device (see page [13](#)).
2. Click the **Decoding** tab.

The Decoding page has three panels:

- The top panel provides general settings (see next section).
- The bottom **Code Items** panel allows you to set up a specific output sequence (see page [44](#)).
- Use the middle panel Use the second panel to choose options for the sequence matching.

General Decoding Settings

The top panel of the Decoding page provides parameters that may be dependent on the scanner's operating mode (see page [25](#)).

Setting	Description	Default
Re-Read Delay	In Presentation and Streaming Presentation mode, the time period (in milliseconds) before the scanner can read the same barcode a second time. Setting a reread delay protects against accidental rereads of the same barcode. Longer delays are effective in minimizing accidental rereads. Use shorter delays in applications where repetitive barcode scanning is required.	750ms
Read Timeout	In Internal and External Trigger modes, the time limit for the scanner's trigger when using external signal or commands to trigger the scanner. Once the scanner has timed out, activate the scanner either by a re-start external signal or using the trigger command.	30,000ms
Good Ready Delay	In Internal and External Trigger modes, the minimum amount of the time before the scanner can read another barcode.	0ms

Setting	Description	Default
DPM Decoding	Use this setting when scanning Direct Part Marking (DPM) barcodes that are etched or imprinted directly into the surfaces of materials including metal and plastic. Options include: <ul style="list-style-type: none"> • Disable • Dot Peen DPM • Reflective DPM Optimizes the scanner to read DPM codes printed on objects with reflective surfaces. Since this option is also effective when reading dotted DPM codes, this option is recommended for DPM.	Disable
Decode Timeout	The maximum time duration that the scanner uses to decode each image.	250ms
ROI Mode	Set the Region of Interest (ROI) for decoding. Options include: <ul style="list-style-type: none"> • Disable ROI is disabled and the entire original image is sent to the decoder. • Standard ROI Use the aimer position to weight activity Activity calculated on the row and the column in the middle of each cell. The ROI window may not include the aimer. • Standard ROI-Aimer centered Activity calculated on the row and the column in the middle of each cell. The ROI window will always include the aimer. • DPM ROI-Aimer centered Activity calculated on 4 rows and 2 columns in each cell. The ROI window will always include the aimer. • Presentation ROI Ignore aimer position, no weight activity. Activity is calculated on the row and the column in the middle of each cell. The ROI window may not include the aimer. 	Disable
Infinite Symbol Delay	Same symbol contents will be checked without consideration of the scan interval time.	Disable
Code Buffer Depth	The number of buffered symbols for symbol delay check when Infinite Symbol Delay is enabled,	8

Output Sequences

The middle and lower panels of the Decoding tab allow you to set up output sequences and the rules for matching those sequences.

Matching Rules

To enable output sequence matching, select the **Decoding** tab and use the following settings:

Setting	Description	Default
Output Mode	<p>Off: the barcode data is output to the host as the scanner decodes it (no sequence matching).</p> <ul style="list-style-type: none"> • Required All output data must conform to an edited sequence, or the scanner will not transmit the output data to the host device. • On/Not Required The scanner will attempt to get output data to conform to an edited sequence but, if it cannot, the scanner transmits all output data to the host device as is. • NoRule The output data will not conform to the edited sequence, it will buffer all the decoded data and output it when the timeout occurs or the data numbers meet the scan count. The scan count can also be set. 	Off
Transmit Partial Sequence	<p>If an output sequence operation is terminated before all output sequence criteria are met, the barcode data acquired to that point is a “partial sequence”.</p> <p>Disabling this function will discard partial sequences when the output sequence operation is terminated before completion. Enabling this function will transmit the partial sequences. (Any fields in the sequence where no data match occurred will be skipped in the output.)</p>	Disable
Separator	Add separators to the output sequences.	
Partial Prefix	Add a prefix to partial output sequences.	
Partial Suffix	Add a suffix to partial output sequences.	
Total Timeout	Time limit in milliseconds that the scanner has to read the entire configured sequence. When the timer expires, the current reading process will stop.	
Code Sequence	<p>Controls the output ordering rule when the sequence is output:</p> <ul style="list-style-type: none"> • Random Barcode result will output randomly. • Top-Bottom Barcode result will output from top to bottom according to the coordinates in the image. • Left-Right Barcode result will output from left to right according to the coordinates in the image. 	Random
Partial Read Regard As	If an output sequence operation is terminated before all your output sequence criteria are met, the barcode data acquired to that point is a “partial sequence.” Use this setting to define whether a partial sequence is output as a Good Read or an Error Read.	Error Read

Code Items

The lower panel of the Decoding tab allows you to program the scanner to output data (when scanning more than one symbol) in whatever order your application requires, regardless of the order in which the barcodes are scanned.

To apply the output sequence, edit the matching rules in the middle panel before executing it. The following items can be added into the matching sequence:

Rule	Description
Code ID	The order of the symbologies in the sequence. Use the arrow buttons to move symbologies up or down.
Code Type	Designates the specific symbology type that you want to apply to the output sequence.
Length	Specifies what length (up to 9999 characters) of data output will be acceptable for this symbology. 9999 is a universal number, indicating all lengths. When calculating the length, you must count any programmed prefixes, suffixes, or formatted characters as part of the length (unless using 9999).
Head String	Specifies the first character(s) you want to match. 99 is the universal number, indicating all characters.

Add or Modify an Output Sequence

1. Select a scanner in the Devices panel.
2. Click the **Decoding** tab
3. Set the matching rules in the middle panel.
4. Set up the sequence in the lower panel:
 - To add an item, click **Add Code**.
 - To remove an item, click **Delete**.
 - Use the arrow buttons to adjust the order of items.
5. Click **Active** to configure the edited output sequence into the scanner. This new sequence will take effect immediately.

This chapter explains how to configure input and output settings.

Input Channel Settings

The scanner has two inputs protected by two polarity-insensitive optocouplers: Input 1 and Input 2. They are both used as external triggers. The main function is acquisition triggering in External Trigger Mode. By default, Input 1 and Input 2 are set to a polarity of “None”. The input signals are fully user programmable.

Polarity and Debounce Time

Select a connected device (see page 13), then select the **I/O** tab in DataMax. There are two input options:

Setting	Description	Default
Polarity	The active state of these inputs is: NONE, Rising Edge, Falling Edge, Low Level, High Level.	None
Debounce time	Anti-disturbance filter.	2

To set Input1 or Input2 work as external trigger, set Operation Mode to External Trigger Mode, including One Shot Mode, Burst Mode, and Continuous Mode.

For example:

If Polarity is set to Low Level, set the Operation Mode to Continuous. The low level will start decoding a barcode and the high level will stop decoding. If the scanner gets the barcode data during the low level, it will also stop decoding.

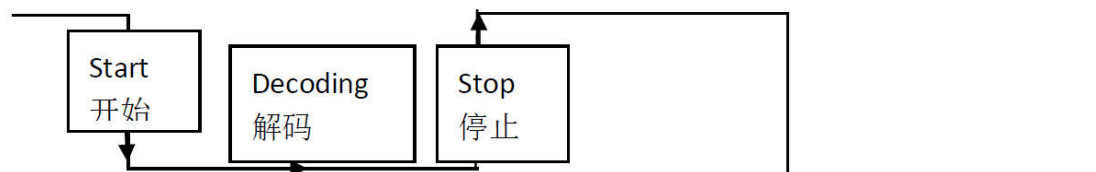

If Falling Edge is selected, set the Operation Mode to Continuous Mode. The Falling signal will start decoding a barcode and stop when the reading timeout occurs or when the correct barcode data is obtained.

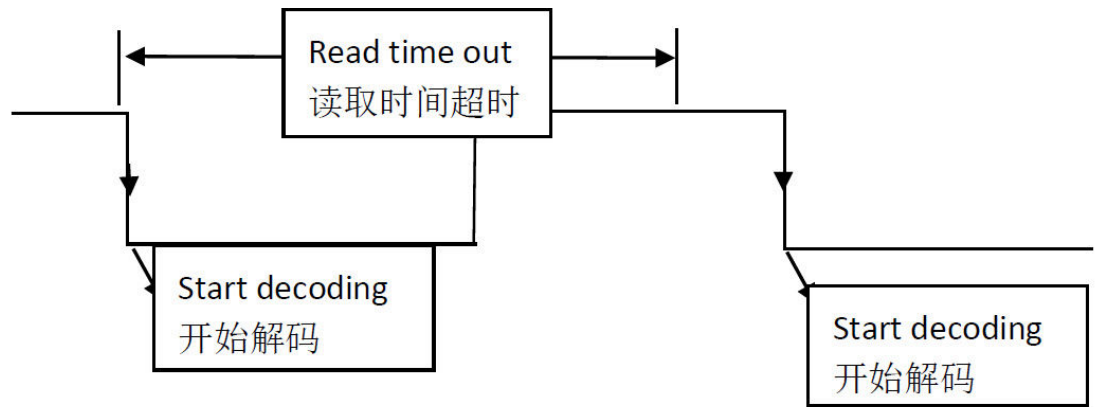

Output Channel Settings

Two general purpose outputs are available, with the protection of 2 optocouplers. Output 1 and Output 2 can be defined by the user and are typically used either to signal the data collection result or to control an external lighting system.

The following settings are available for Output1 and Output2:

Setting	Description	Default
Message/Event	The signal will be asserted/de-asserted if the configured event occurs. <ul style="list-style-type: none"> Off Always On Good Read Activates when all the selected codes are correctly decoded. Error Read No Read Activates when the code(s) signaled by the external trigger are not decoded. 	Off
Duration Time	The length of time the signal will asserted.	100ms
Output Delay Time	The signal will be delayed for the specified time, then asserted after the specific event occurs.	100ms

EXAMPLE:

If Output 1 is configured with Good Read Event, Duration Time 100ms, and Output Delay Time is set to 100ms.

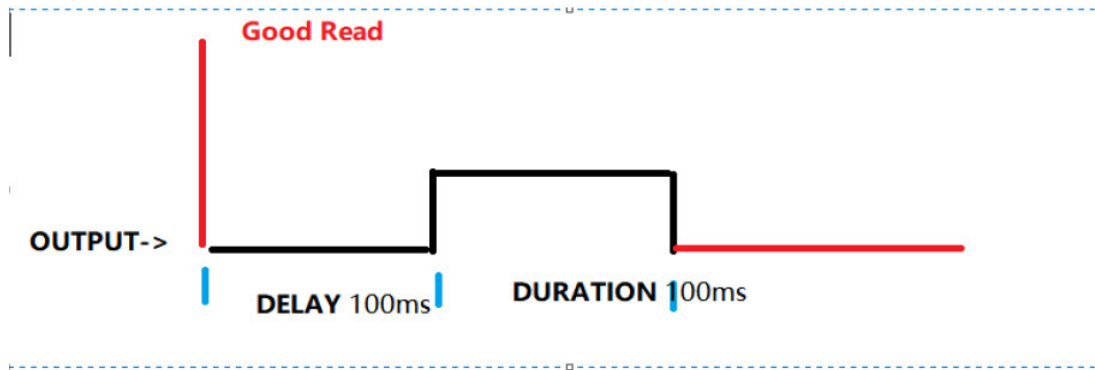

DATA EDITING AND FORMATTING

This chapter explains how to edit and format data using DataMax.

Prefix/Suffix Overview

When a barcode is scanned, additional information is sent to the host computer along with the barcode data. This group of barcode data and additional, user-defined data is called a “message string”. Use the **Data** tab to build user-defined data into the message string.

Prefix and suffix characters are data characters that can be sent before and after scanned data. The data characters can be sent with all symbologies, or only with specific symbologies.

Prefix	Scanned Data	Suffix
---------------	---------------------	---------------

Add a Prefix/Suffix

1. Select a connected device (see page [13](#)).
2. Click the **Data** tab.
A prefix or suffix may be added or cleared from one symbology or all symbologies.
3. Select symbologies and click **Add**.
4. Enter characters in the setting prefixes/suffixes fields. You can also select from the displayed keyboard of common prefixes or suffixes.

The default is no prefix or suffix.

EXAMPLE:

1. Select all symbologies.
2. Select a prefix and suffix.

The screenshot shows a software interface with two main sections. The top section is titled 'Symbologies' and contains a dropdown menu set to 'All Symbologies' and an 'Add' button. Below this is a table with one row: '1 All Symbologies', with 'Delete' and 'View' buttons to its right. The bottom section is titled 'Settings' and contains two input fields: 'Prefix' with the value 'ABC' and 'Suffix' with the value 'ED33'.

3. When the following barcode is input, the data is output as:
ABC1234567890ABCDEFGHIJED33



Remove a Prefix/Suffix

To clear a prefix or suffix, delete the text in the corresponding field.

Data Format Editor Introduction

Use the Data Format Editor to change the device's output. For example, you can insert characters at certain points in the barcode data as it is scanned. Changing the data format is optional. The default is to output the original data content as is.

The maximum size of a data format configuration is 2000 bytes, which includes header information.

Add a Data Format

1. Select the **Data** tab.
2. Select the symbology from the symbologies list and click **View** to select the detail settings.

3. Choose from the following data formats:

String	Description
Full Code String	Include in the output message all of the characters from the input message, starting from the current cursor position, followed by an insert character.
Sub Code String	Include in the output message a number of characters followed by an insert character. Start from the "Start position" input by the user and continue for "Length" characters or through "Drop Last Length" the character in the input message.
Code Type Name	Insert the name of the barcode's symbology in the output message, without moving the cursor. Only symbologies with a Honeywell ID are included.
Code Length	Insert the barcode's length in the output message, without moving the cursor. The length is expressed as a numeric string and does not include leading zeros.
Insert String	Insert a string into the output message.

When working with the Data Format Editor, a virtual cursor is moved along your input data string. The commands in the table above are used to both move this cursor to different positions and to select, replace, and insert data into the final output. The data will be added after the prefix and before the suffix (if used) in the order listed in the data panel.

EXAMPLE:

1. Select a symbology then click **Add**.
2. Click **View**.
3. Add data formats in the right-hand panel.

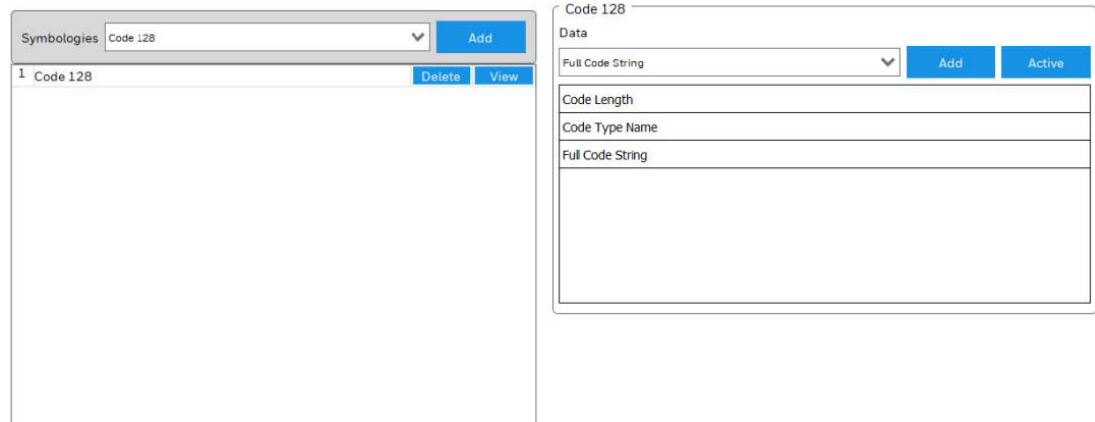

4. Click **Active**.

5. After the following barcode is scanned, the data is output as:
20Code1281234567890ABCDEFGHIJ



Delete a Data Format

To clear a data format, right-click on the format then click **Delete**.

Advance Mode (Command Line)

Advance Mode is used to edit the data format by command line. Using the command line allows data formats to be used more flexibly.

MAINTENANCE AND TROUBLESHOOTING

Software and Firmware

Software Downloads

Product support is available online through the [Technical Support Portal](#). Software and firmware can be accessed through the [Software Downloads](#) portal. You will need to create a login account for portal access. Additional information such as purchased date, service agreement number, maintenance plan number, or software license number may be required for downloads.

1. Go to honeywell.com/PSSsoftware-downloads.
2. Create a login account if you have not already created one.
3. Install the Honeywell Download Manager tool. See “Note” on the portal page. This tool is required for downloads.
4. Locate the app or firmware update you want to download in the Software directory.
For example: **Software > Barcode Scanners > Industrial > HF800 > Configuration Software > DataMax.zip** (actual path may vary).
5. Select **Download**. Follow the prompts to download the file.

Firmware Upgrades

You can use DataMax to upgrade the scanner’s firmware.

1. Download updated firmware (see previous section).
2. Open DataMax and connect a device (see page [13](#)).
3. Click .
4. Select **Firmware Update**.
5. Click **Choose file** and select the .SMOC file.

6. Click **Open**. The device will restart automatically after the file transfer is completed. Please do not turn off device power, during the upgrade.

Restore Factory Defaults

You can reset the scanner to factory defaults either by using the Tune button on the scanner's control panel or through DataMax.

All environment parameters will be restored to factory default values and any existing configurations stored on the device will be erased. The device will be reset and will start in run mode with the factory default configuration.

Reset with the Tune Button

1. Press and hold the Tune button on the scanner for more than 20 seconds.
The Train LED will blink at 500ms intervals to indicate the scanner is waiting for you to confirm you want to reset to the default configuration.
2. Press the Tune button again within 10 seconds to confirm. The scanner reverts to the default configuration. The beeper will sound a menu good read beep to indicate a successful reset, and the Read LED will be green.
If you do not press the Tune button again within 10 seconds, the reset to default is canceled, and the scanner keeps the current configuration.

Reset with DataMax

1. Open DataMax and connect to a device (see page [13](#)).
2. Click .
3. Select **Reset To Default**.
4. If you do not want to save the current settings, click **No**.
Or
Click **Yes** to save the current settings to a .cfg file. Select a location and a file name, then click **Save**.
5. Click **Yes** to reset to factory defaults. Or click **No** to cancel the reset process.

Repairs

Repairs and/or upgrades are not to be performed on this product. These services are to be performed only by an authorized service center (see [Customer Support](#) on page vii).

Maintenance

Your device provides reliable and efficient operation with a minimum of care. Although specific maintenance is not required, the following sections describe periodic checks to ensure dependable operation.

Clean the Scanner

The scanner housing and scanner window may be cleaned with a soft cloth dampened with water or a mild detergent-water solution. If a mild detergent solution is used, wipe the scanner or base with a clean cloth dampened only with water to remove any detergent residue.

Note: *Reading performance may degrade if the scanner's window is not clean. If the window is visibly dirty, or if the scanner isn't operating well, clean the window.*



Caution: **Do not submerge the scanner in water or cleaning solution. Do not use abrasive wipes or cloths on the scanner's window. Abrasive wipes may scratch the window. Never use solvents (e.g., acetone) on the housing or window. Solvents may damage the finish or the window.**

Caution: **Ensure all components are dry prior to mating the scanner with charging accessories or other peripheral devices. Mating wet components may cause damage not covered by the warranty.**

Inspect Cords and Connectors

Inspect the interface cable and connector for wear or other signs of damage. A badly worn cable or damaged connector may interfere with scanner operation. Contact your distributor for information about cable replacement.

Troubleshooting

Issue	Suggestion
DataMax installation	Check the following points, and then install the software again. <ul style="list-style-type: none">To install the software, log on as a user with Administrator rights.The installation may be impeded by security software. Temporarily disable the security software.
DataMax running	When DataMax runs for the first time after installation, it may be blocked by a firewall. If the system may ask you to confirm DataMax's access to the network, be sure to click the allow option.

Issue	Suggestion
Power is on but the Power LED is not lit.	Verify power is connected, If using a power adapter, please make sure to use the Honeywell recommend power adapter. If using customer power, please make sure it is properly wired with Vin and GND on the connector. See Terminal Pinouts on page 64.
Unable to connect to DataMax.	Check the following: <ul style="list-style-type: none"> • RS232/485 connection (page 6) • Ethernet connection (page 6) • Make sure the unit is properly configured to the related working mode.
Device is not displayed in the Device Selection Area	To be discoverable by DataMax, online devices must be powered on and connected to the Local Area Network. If you do not see the desired device within this list, please verify its connection to the LAN and ensure it is powered on; then click  to run a new device search. If a device is connected via serial port, be sure to select the correct parameters (Data Bits/Stop Bits/Parity).
Reading failure	<ul style="list-style-type: none"> • Tune the Acquisition Delay on Trigger if the moving code is out of the scanner field of view. • Set the streaming presentation/presentation Operating Mode if no external trigger source is available. • Fine tune the Image Setup to improve the code image quality. • Check the code parameter settings in the Symbology Setup step: 2D, Linear, and Stacked Linear. • View the full resolution code image to check the printing or marking quality.
Unable to trigger the device with external trigger source or soft trigger	Ensure the external sensor wiring is correct. Check the I/O input according to external sensor parameter.
Communication: device is not transmitting anything to the host	<ul style="list-style-type: none"> • Make sure the wire is properly connected. • Make sure the configuration is related to the actual working mode. • Verify that the host serial port settings are the same as the scanner serial port settings.
Communication: data transferred to the host is incorrect	In DataMax, check the Prefix and Suffix String settings and other parameters on the Data tab.

PRODUCT SPECIFICATIONS

HF800 Product Specifications

Parameter		
Mechanical		
	Horizontal Model:	Vertical Model:
Length	2.15 inches (54.5mm)	2.88 inches (73.2mm)
Width	2.07 inches (52.5mm)	2.07 inches (52.5mm)
Height	1.14 inches (29mm)	1.14 inches (29mm)
Weight	7.41 oz (210g)	9.35 ounces (265g)
Electrical		
Voltage Requirements	10VDC to 30 VDC	
Current Draw	Maximum 5A	
Environmental		
Temperature Ranges:		
Operating	0°C to 50°C	
Storage	-20°C to 70°C	
Humidity	<90%	
Sealant Range	IP65	
Image		
Image Size	838×640	

Depth of Field

Refer to the following tables to adjust installation distance.

DOF=L1~L2

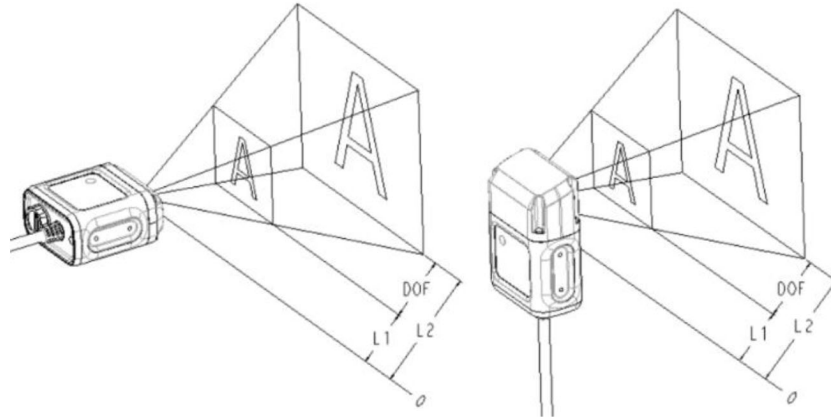

Symbology	Horizontal	Vertical
HD	Standard (L1~L2)	Vertical (L1~L2)
4 mil Code 38	50~80 mm	25-55 mm
5 mil Code 39	30~115 mm	25~90 mm
13 mil UPC	40~175 mm	25-150 mm
10 mil Data Matrix	22~128 mm	25-105 mm
20 mil Data Matrix	23~195 mm	25-170 mm
SR	Standard	Vertical
5 mil Code 39	64~140 mm	39-115 mm
13 mil UPC	55~405 mm	30-380 mm
10 mil Data Matrix	62~190 mm	37-165 mm
20 mil Data Matrix	47~375 mm	25-350 mm
ER	Standard	Vertical
5 mil Code 39	147~218 mm	122-193 mm
13 mil UPC	71~480 mm	46-455 mm
10 mil Data Matrix	135~250 mm	110-225 mm
20 mil Data Matrix	102~400 mm	77-375 mm

Field of View Calculation

Use the data in the following table and the formula below to calculate Field of View (FOV).

$$FOV_{range} = 2[(L_0 + L) * \tan (\theta / 2)]$$

EXAMPLE: HF800HD-1-1H @ 50mm

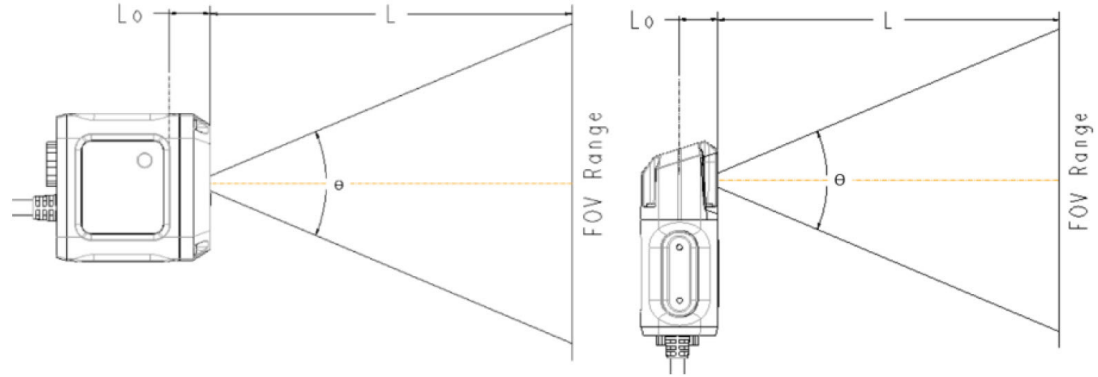

Model	L_0 (Internal Distance/mm)	θ_H (Horizontal angle)	θ_V (Vertical angle)
HF800HD-1-1H	5	41.4	32.2
HF800SR-1-1H	5	42.4	33
HF800ER-1-1H	5	31.6	24.4
HF800HD-1-1V	25	41.4	32.2
HF800SR-1-1V	25	42.4	33
HF800ER-1-1V	25	31.6	24.4

Connector Pinouts

Note: The following pin assignments are not compatible with all Honeywell products. Use of a cable with improper pin assignments may lead to damage to the product. Use of any cables not provided by the manufacturer may result in damage not covered by your warranty.

HF800 D-Sub 25-Pin Male Connector

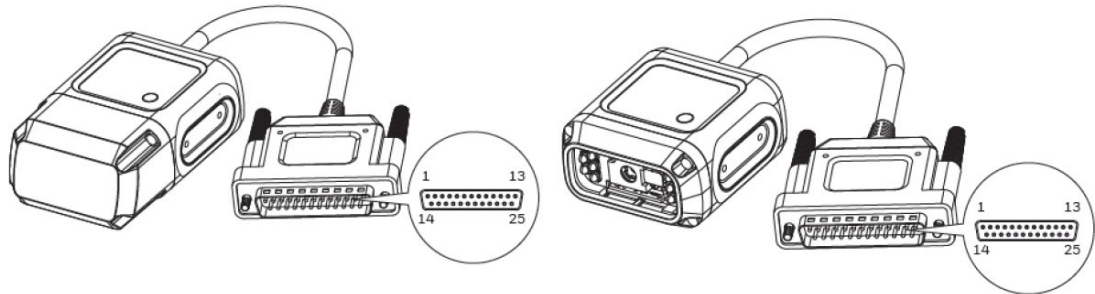

Power, COM and I/O Connector Pinouts		
Pin Number	Name	Description
9, 13	Vin	Power supply input (10VDC-30VDC)
7, 25	GND	Power supply ground
1	Shield	Chassis shield
2	RS232_TX	TXD (output)
3	RS232_RX	RXD (input)
4	RS232_RTS	RTS (output)
5	RS232_CTS	CTS (input)
6	IN2A	External input channel 2A
10	IN2B	External input channel 2B
18	IN1A	External input channel 1A
19	IN1B	External input channel 1B
8	O1+	Positive output 1
22	O1-	Negative output 1
11	O2+	Positive output 2
12	O2-	Negative output 2
14	RS485_Z	RX- (RS422 RX- only) (input)
15	RS485_Y	RX+ (RS422 RX+ only) (input)
16	RS485_A	T/R+ (RS485 data+ and RS422 TX+)
17	RS485_B	T/R- (RS485 data- and RS422 TX-)
20, 21, 23, 24	Reserved	Reserved

Output

There are two digital outputs (Output1, Output2), with the protection of two optocouplers. The maximum VCE of the optocoupler is 30VDC; maximum continuous current is 50mA. There are two TVS diodes paralleled with these Output pins; maximum voltage applied to these TVS is 30VDC. Adjust the VDD and the load resistance to make sure the current is less than 50mA and the VDD is less than 30VDC. You can use these two outputs to control the beeper and external illumination LEDs.

Typical use case:

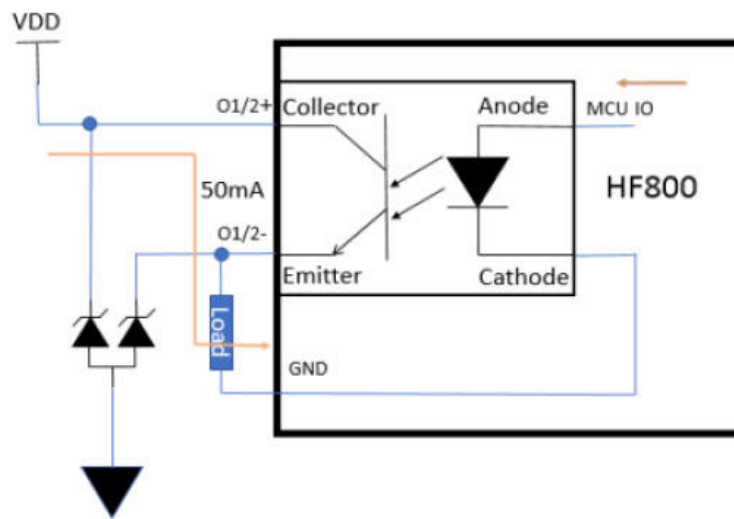
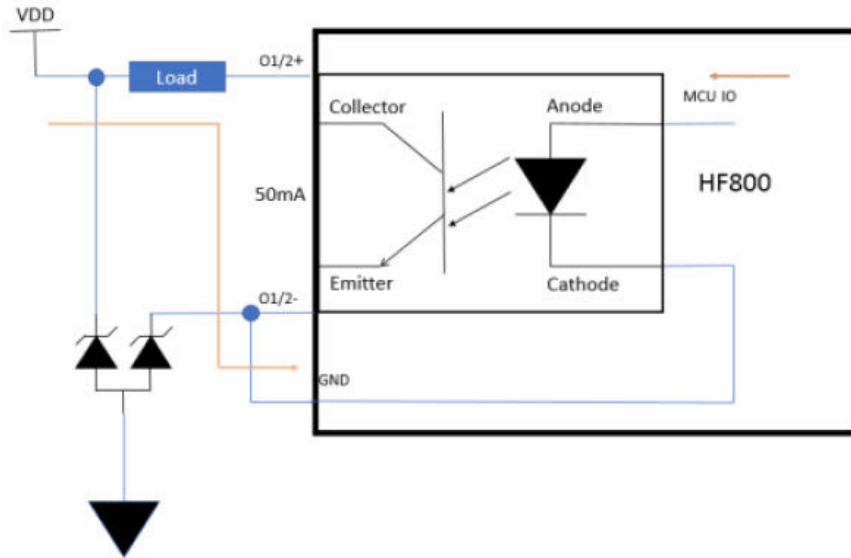

Input

There are two digital inputs (Input1, Input2), with the protection of two polarity-insensitive optocouplers. Typical forward voltage of the optocoupler is 1.35V; maximum currents is 50mA. Adjust the VDD and the serial resistor to make sure the current is less than 50mA. The VDD should be more than 1.35VDC and less than 30VDC. Maximum input frequency is 100KHz. You can connect an external IR trigger and PLC to these two inputs.

Typical Use Case:

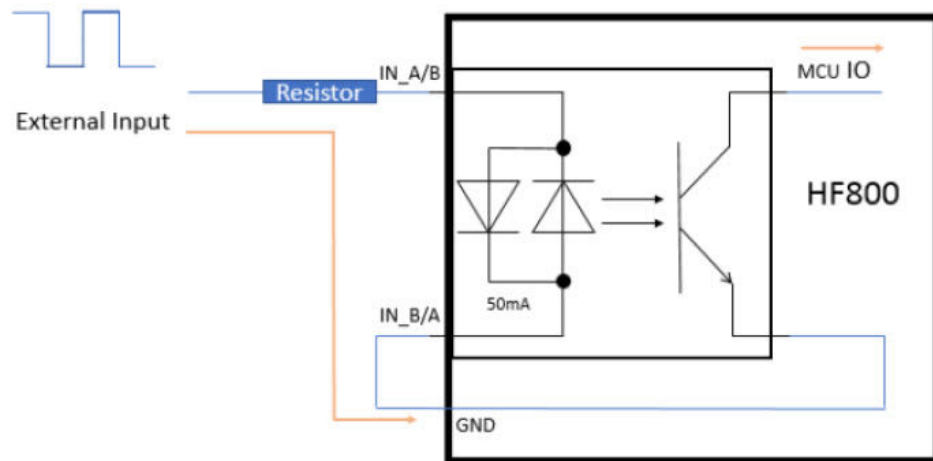
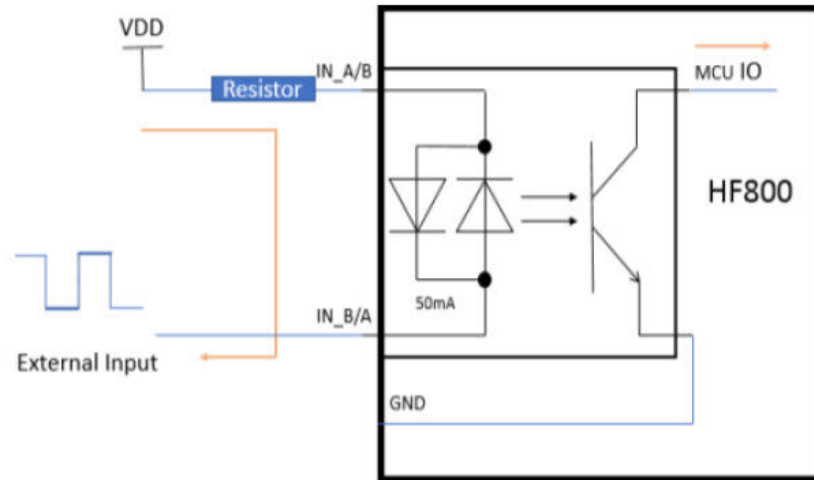

NPN

The connection layout of a typical NPN type IR and input 2 is shown below. The connection of input 1 is similar: just replace IN2A with IN1A and IN2B with IN1B. A series resistor (1Kohm to 1.5Kohm) is recommended between V+ and IN2A to limit the current.

NPN type IR connected to external I/O+RS232 cable:

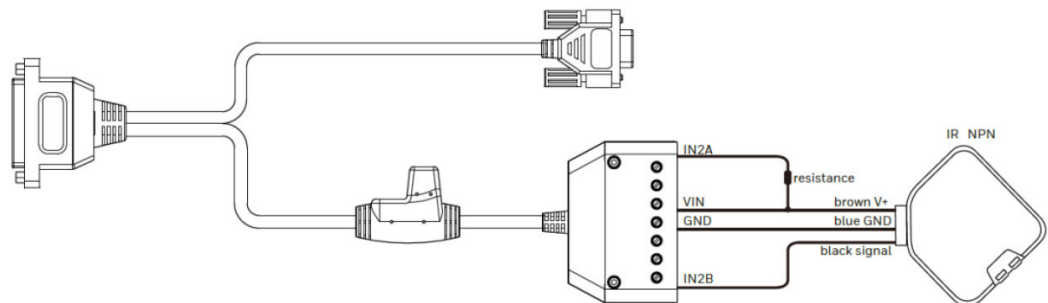

NPN type IR connected to external I/O+RS485/422 cable:

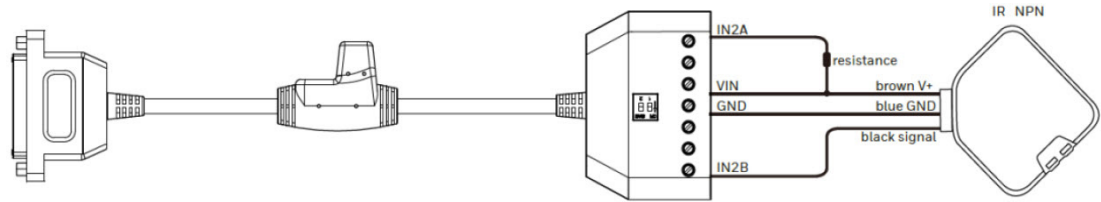

PNP

The connection layout of a typical PNP type IR and input 2 is shown below. The connection of input 1 is similar: just replace IN2A with IN1A and IN2B with IN1B. A series resistor (1Kohm to 1.5Kohm) is recommended between the signal and IN2A to limit the current.

PNP type IR connected to external I/O+RS232 cable:

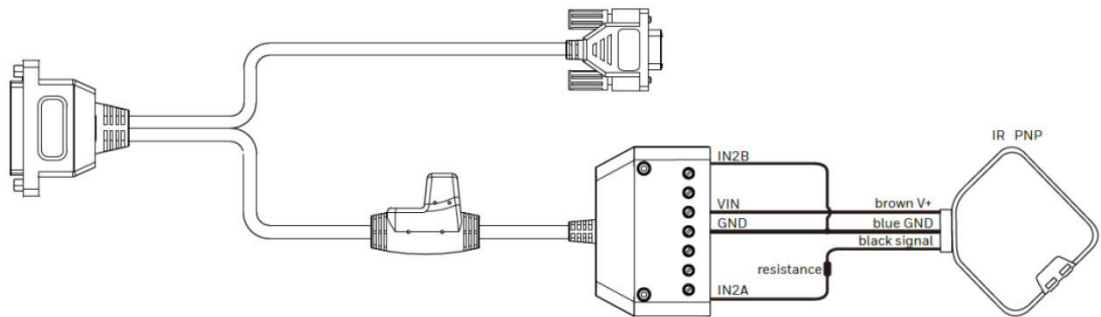

PNP type IR connected to external I/O+RS485/422 cable:

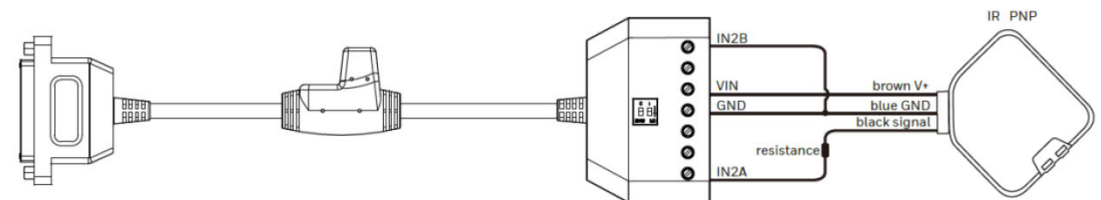

RS232

The HF800 supports RS232 communication (hardware dataflow control configurable). Default baud rate is 115200 and can be configured to 4800, 9600, 19200, or 38400.

RS485 and RS422

The HF800 supports both RS485 and RS422 communication. Baud rate is 115200 fixed. Use one at a time (485 or 422). When using RS485, connect 485 data+ to RS485_A, connect 485 data- to RS485_B. RS485_Y and RS485_Z are for RS422 RX only.

Ethernet M12 Connector

The HF800 supports one 10/100M adaptable Ethernet connection. DHCP is enabled by default. If disabled, the default IP is 192.168.1.110 and the subnet mask 255.255.255.0. The M12 A coding connector is waterproof. M12 to RJ45 Ethernet transform cables can be purchased from Honeywell.

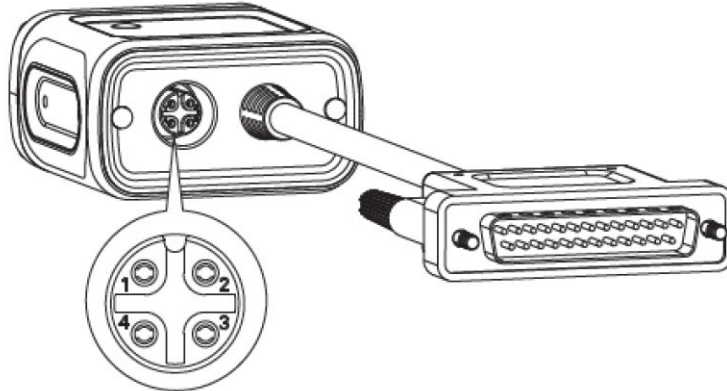

HF800 Ethernet Connector Pinouts		
Pin Number	Name	Description
1	TX+	Transmitted data (+)
2	TX-	Transmitted data (-)
3	RX+	Received data (+)
4	RX-	Received data (-)

Terminal Pinouts

External I/O+RS232 Cable

Standard DB9 female connector for RS232. The RS232 cable is 1.5m long and has a DC jack for a power adapter and a 14-pin connector for input and output. The I/O cable length is 1.2m.

Note: Connect the shield to ground for better EMC performance.

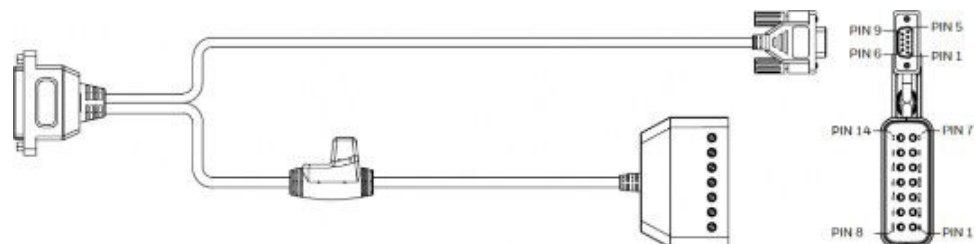

Female DB9 Connector:

Pin Number	Name	Description
1	Shield	Shield
2	RS232_TX	RS232_TX (output)
3	RS232_RX	RS232_RX (input)
5	GND	Ground
7	CTS	CTS (input)
8	RTS	RTS (output)
6, 7, 13, 14	Reserved	Reserved

14-Pin Connector:

Pin Number	Name	Description
1	Vin	Power supply
2	IN1B	External input 1B (polarity insensitive)
3	IN1A	External input 1A (polarity insensitive)
4	IN2B	External input 2B (polarity insensitive)
5	IN2A	External input 2A (polarity insensitive)
8	GND	Power supply ground
9	O1+	Positive output 1
10	O1-	Negative output 1
11	O2+	Positive output 2
12	O2-	Negative output 2
6, 7, 13, 14	Reserved	Reserved

I/O+RS232 Discrete Wiring Cable

This cable is available in two lengths: 5m and 10m. The tinned conductor is 10mm.

Note: Connect the shield to ground for better EMC performance.

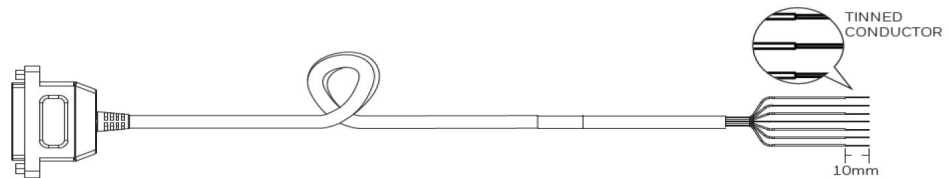

Discrete Wire:

Color	Signal	Description
Drain Black	Shield	Shield
Brown	RS232_TX	RS232_TX (output)
Blue	RS232_RX	RS232_RX (input)
Orange	RS232_RTS	RS232_RTS (output)
Yellow	RS232_CTS	RS232_CTS (input)
Red	VIN	Power supply
Black	GND	Power supply ground
White	IN2A	External input 2A (polarity insensitive)
Violet	IN2B	External input 2B (polarity insensitive)
White/Brown	O2+	Positive output 2
White/Red	O2-	Negative output 2
White/Blue	IN1A	External input 1A (polarity insensitive)
White/Green	IN1B	External input 1B (polarity insensitive)
Green	O1+	Positive output 1
Gray	O1-	Negative output 1

External I/O+RS485/422 Cable

There are two switches on the 485/422 cable. If the switch is in the On position, HF800 485/422 will terminate with 120ohm. If the switch is Off, there will be no termination resistor. There is a DC jack for a power adapter. Cable length is 1.2m.

Note: For better signal quality, confirm that there are two 120ohm termination resistors on the data line (between data+ and data-): one near the host and the other one on the end.



14-Pin Connector:

Pin Number	Name	Description
1	Vin	Power supply
2	IN1B	External input 1B (polarity insensitive)
3	IN1A	External input 1A (polarity insensitive)
4	IN2B	External input 2B (polarity insensitive)
5	IN2A	External input 2A (polarity insensitive)
8	GND	Power supply ground
9	O1+	Positive output 1

Pin Number	Name	Description
10	O1-	Negative output 1
11	O2+	Positive output 2
12	O2-	Negative output 2
RS485-422		
6	RS485_A	T/R+
7	RS485_B	T/R-
13	RS485_Y	RX+
14	RS485_Z	RX-

To power the HF800, use either an adapter via the DC jack or a DC source via the Vin pin in the 14-pin connector. When an adapter is used, other accessories, such as beeper, external illumination or even another HF800 could draw current from the adapter via the Vin pin in the 14-pin connector. Total power consumption should not exceed 15W.

Ethernet Cable

M12A coding 4-pin to RJ45 Ethernet cable. The Ethernet cable is available in two lengths: 2m and 5m.



M12 Pin Number	RJ45 Pin Number	Signal	Description
1	1	TX+	Transmitted data (+)
2	2	TX-	Transmitted data (-)
3	3	RX+	Received data (+)
4	6	RX-	Received data (1)

Required Safety Labels

Horizontal Model

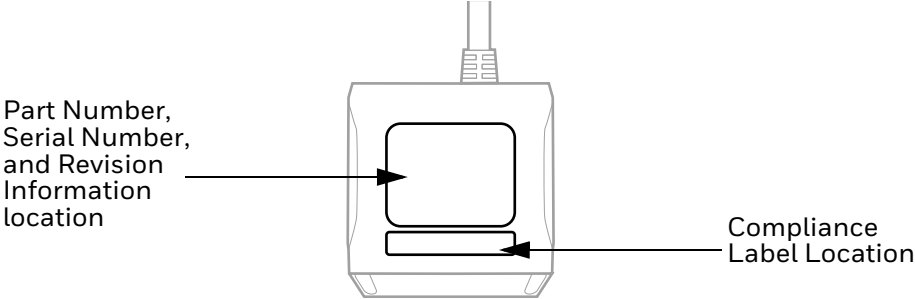

Vertical Model

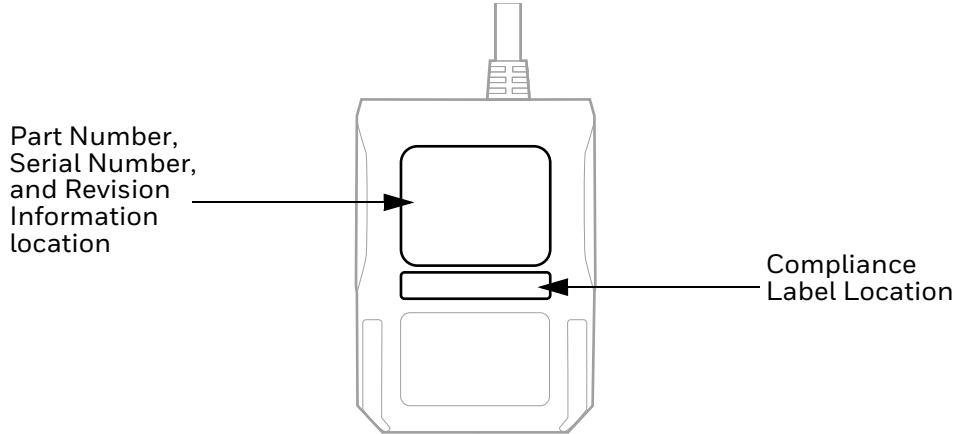

Network DHCP

Function will take effect after you restart the device



NWKDHP1.
Enable Network DHCP



NWKDHP0.
Disable Network DHCP

Reboot the Scanner



RESET_
Reboot

Honeywell
855 S. Mint Street
Charlotte, NC 28202

sps.honeywell.com