



PM45c

Mid-Range Industrial Printer

Quick Start Guide

Out of the Box

Make sure the shipping box contains these items:

- Printer
- Power Adapter
- Power Cord (see note below)
- Product Documentation

Note: *Power cord inclusion is SKU dependent and may need to be ordered separately. Contact your local sales representative for assistance.*

If you have ordered accessories for your printer, verify that they are included in the order. Be sure to keep the original packaging in case you need to return the printer.

Printer Features

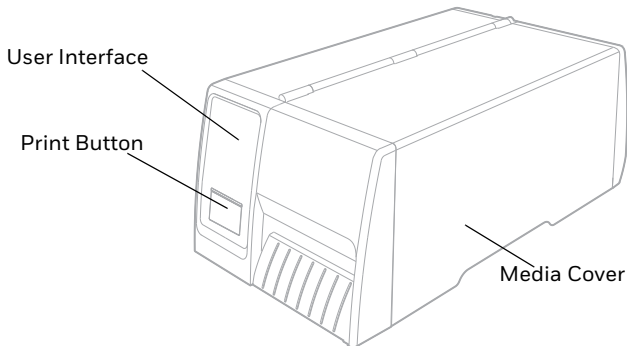

Internal View

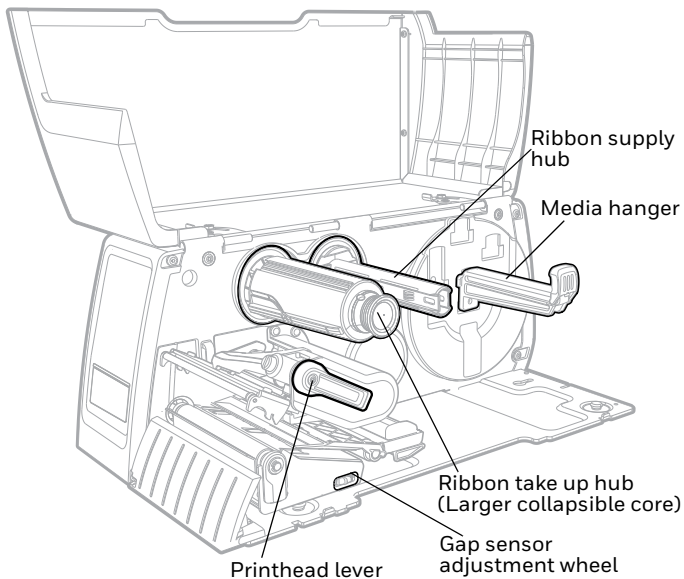

Load Media

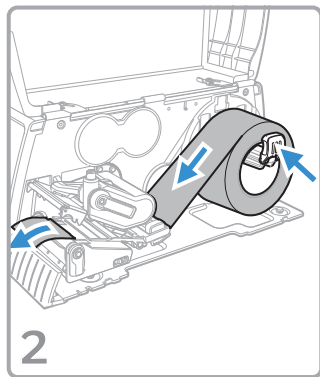
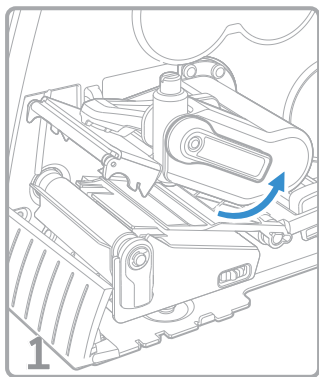
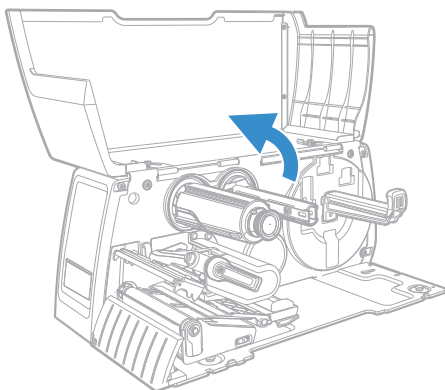

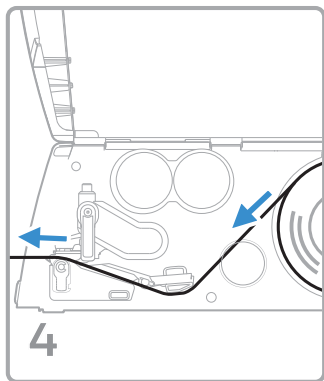
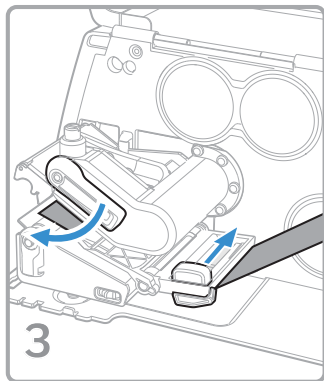

Load Ribbon

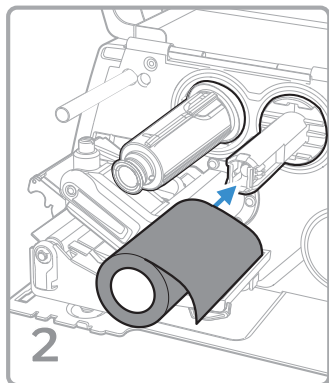
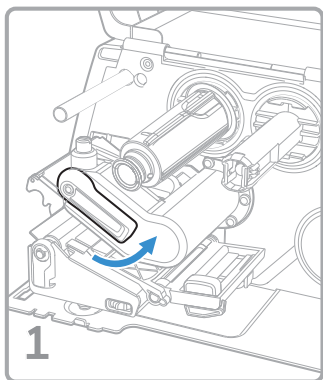

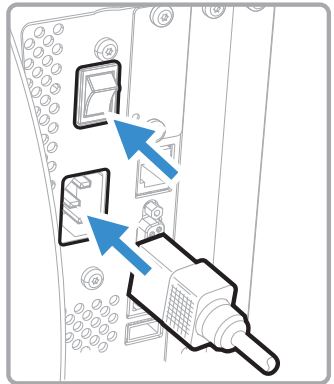
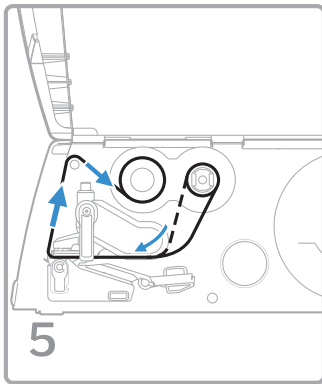
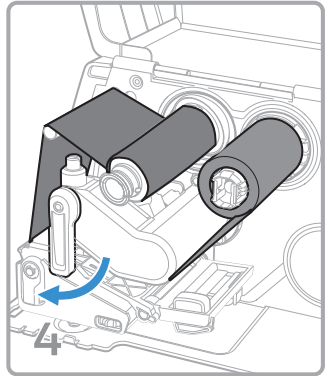
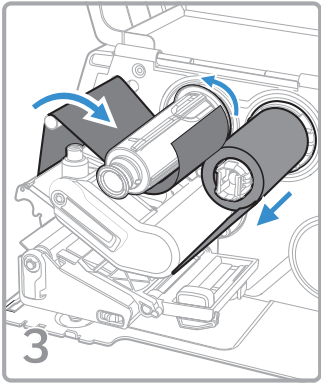

Front Panel and Display









LED ICON DISPLAY







TOUCHSCREEN DISPLAY

LED Icon Display - Color and Indication

LED Display Status Indicators	Color	Indication
 Wi-fi Signal	White	Wireless Signal.
	Off	Wireless radio disabled or not installed.
 Connectivity	White	Steady connection.
	Off	No data is being sent or received.





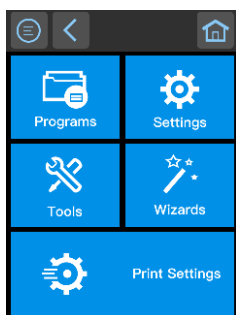
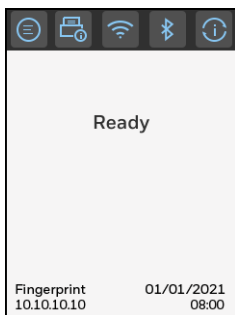

LED Display Status Indicators	Color	Indication
 Bluetooth	White	Bluetooth is enabled.
	Off	Bluetooth is disabled or not installed.
 Media	Red	Out of media or there is problem with the media (jammed, not loaded correctly).
	Off	Media is available and loaded correctly.
 Printer Configuration	Red	There is printer configuration problem.
	Off	There are no configuration problems.
 Ribbon	Red	Out of ribbon or there is problem with the ribbon (not feeding or loaded incorrectly).
	Off	Ribbon is good or the printer is not configured to use ribbon.
 Printhead Hot	Red	The printhead is too hot.
	Off	The printhead temperature is normal and ready for printing.

LED Display Status Indicators	Color	Indication
 Printhead Lifted	Red	Printhead is lifted.
	Off	Printhead is lowered.
 General Error	Red	There is printer problem not associated with any of the other icons.
	Off	There are no general errors.
 Pause	White	The printer is paused.
	Off	The printer is not paused.
 Maintenance	Amber	Maintenance is required and a lifetime odometer setting is reached.
	Off	No maintenance is required.

Touchscreen Printer - Ready Screen and Main Menu



Touchscreen Menu Icons

Touchscreen Menu Icons	Press to:
 Main Menu	View the main menu of the printer.
 Communications	View communications information for the printer.
 Printing	View specific printer information.
 Wi-Fi Connectivity	View Wi-Fi connection information.
 Bluetooth	View Bluetooth/Bluetooth LE information for the printer.
 Back	Navigate back through the printer menus.
 Home	Return to the Ready screen.

To learn more about printer icons, see the user guide.

Print Button

Use the **Print** button  to feed media, pause print jobs, calibrate, test feed, and print.

Printer State	Print Button Action
Startup	Press the Print button during startup to enter Calibration mode or to restore defaults if the printhead is lifted.
Ready	Press the Print button to advance the media. Press and hold the Print button for smart calibration.
Printing	Press the Print button to stop or pause printing. The printer stops after completing the current label.
Paused	Press the Print button to resume printing.
Error	Press the Print button to advance the media.

Print a Test Label on the LED Display Model

Once the printer is turned on, the printer goes through its startup sequence and all of the LEDs light up. When the last two LEDs are lit (Printhead Hot and Maintenance),

1. Press and hold the **Print** button until the test label starts to print.
2. Release the **Print** button.

Your test label prints.

Print a Test Label with the Touchscreen Printer

Once the printer is turned on, it runs a startup wizard to let you enter basic setup information.

1. Enter all the information on the wizard screens. Click **No** when prompted to run other wizards.
2. From the Ready screen, tap the **Main Menu**  button.
3. From the Main Menu, tap **Tools > Test Labels**.
4. Select the test label you want to print and tap it.

Your test label prints.

Support

To search our knowledge base for a solution or to log into the Technical Support portal and report a problem, go to www.sps.honeywell.com.

Documentation

Product documentation is available at www.sps.honeywell.com.

Limited Warranty

For warranty information, go to www.sps.honeywell.com and click **Support > Warranties**.

Patents

For patent information, see www.hsmpats.com.

Trademarks

Bluetooth trademarks are owned by Bluetooth SIG, Inc., U.S.A. and licensed to Honeywell.

Other product names or marks mentioned in this document may be trademarks of other companies and are the property of their respective owners.

Disclaimer

Honeywell International Inc. (“HII”) reserves the right to make changes in specifications and other information contained in this document without prior notice, and the reader should in all cases consult HII to determine whether any such changes have been made. HII makes no representation or warranties regarding the information provided in this publication.

HII shall not be liable for technical or editorial errors or omissions contained herein; nor for incidental or consequential damages resulting from the furnishing, performance, or use of this material. HII disclaims all responsibility for the selection and use of software and/or hardware to achieve intended results.

This document contains proprietary information that is protected by copyright. All rights are reserved. No part of this document may be photocopied, reproduced, or translated into another language without the prior written consent of HII.

Copyright © 2021-2022 Honeywell International Inc. All rights reserved.