

STS320™



The first-in-class solution to address demanding tire tracking and traceability applications

Datalogic's STS320™ is the first-in-class solution of undisputed reliability for the Tire Industry, offering tire manufacturers complete traceability in all demanding applications along the tire production chain.

PERFORMANCE EXCELLENCE

STS320 delivers outstanding reading performance at the best price/performance ratio because of a superior 2MP sensor (1920 × 1080 pixels 16:9) combined with a powerful dual core processor. In a very compact solution, STS320 achieves an extra-large Field of View (FOV) up to 1250 mm (49") for large conveyor coverage and a high Depth of Field (DOF) even on high resolution codes of 0.25 mm (10 mils) for extreme application flexibility. STS320 works with conveyor speed up to 1.5 m/s and with reduced minimum gap among tires allowing an increase in overall productivity.

EASY & QUICK INSTALLATION

The STS320 is an out-of-the box solution fully pre-assembled, pre-configured and validated in the factory. Together with the self-contained, compact mechanical layout, it makes product handling extremely easy and dramatically reduces installation time. The product configuration is improved by the state-of-the-art DL.CODE™ software common to all Matrix series. The usability is enhanced and simplified by the new cross projection integrated aiming system, 'Green Spot' technology, and the X-Press HMI.

NEW INTUITIVE DIAGNOSTICS

The STS320 performance analysis is boosted by a new web interface and by the new web Mosaic view that allows the monitoring of all the readers at a glance for easy setup and monitoring through a complete suite of remote diagnostics. The new run-time unreadable code detection identifies the presence of damaged labels and the live high-speed image-saving based on the new generation FTP file transfer collects the information for post processing quality analysis aiming to optimize productivity. Performance diagnostics are intuitive and magnified from a distance because of the innovative configurable 360-degree multi-color read feedback for ease of use and operation.

EASY INTEGRATION, MAINTAINANCE AND USE FOR A REDUCED TOTAL COST OF OWNERSHIP

The STS320 is simple to fit and to integrate with its full industrial connectivity, compactness, and top industrial grade. Each single reader replacement is quick and easy for reduced system downtime. The new web Device Discovery simplifies the access and monitoring of all readers in the network. The Sulphur gas resistance allows safe installation of the STS320 in the most challenging environment (curing process). Its undisputed robustness offers unrivalled long-term reliability and life cycle, minimum wear and tear.

The STS320 embodies the full set of application requirements of the Tire Industry that makes it the best solution, once again confirming Datalogic's leadership in the market.

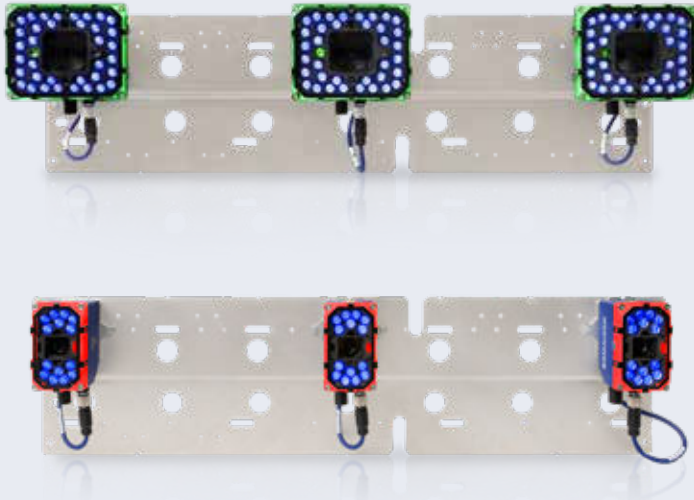

HIGHLIGHTS

- Outstanding reading performance
- Compact and out of the box solution for the quickest installation on the field
- New run time diagnostics and unreadable code classification to increase the overall productivity
- Live and high-speed image saving for post processing analysis
- New web interface and configurable 360-degree visual read feedback
- New web Mosaic view to monitor all the readers
- New web Device Discovery to quickly access all the readers in the network
- Completely new state of the art DL.CODE software
- Unmatched price/performance ratio

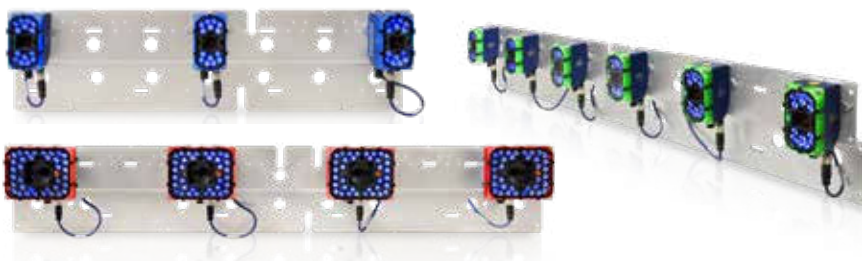

APPLICATIONS

Factory Automation / Manufacturing

Automotive, Tires Manufacturing and Tires Distribution Center

STS320

- Tire and Wheel identification
- Tire tracking and traceability both in Green Vulcanized Tires (curing press) and Finished Tires
- High speed sorting on omnidirectional conveyors
- Bottom (under belt) reading

ATS320

- Tires picking station
- Spinning Tires
- Tire building machine and tire assembly inspection
- Test machine
- Visual inspection machine
- Tire and Wheel identification

TECHNICAL DATA

OPTICAL FEATURES

Sensor Type	Image resolution 2.0 Mpixel (1920 x 1080) 16:9 form factor - 1/3" CMOS global shutter
Frame Rate	40 to 60 frames/s, depending on application
Illumination	Internal illuminators colors: Blue Internal illuminators power: High Power 14 LEDs, Very High Power 36 LEDs
Pitch	± 35°
Tilt	0° - 360°

DECODING CAPABILITY

Readable Symbologies	1D Codes: all standard 1 dimensional symbologies 2D Codes: Data Matrix, QR Code, Micro QR, MAXICODE, Aztec, Dot code Postal Codes: Australia Post, Royal Mail, Kix code, Japan Post, PLANET, POSTNET (+BB), Intelligent Mail, Swedish Post and many more
Code Quality Metrics	1D CQ Standard: ISO/IEC 15416 2D CQ Standard: ISO/IEC 16022/18004, ISO/IEC 29158 (AIM-DPM), ISO/IEC 15415

COMMUNICATIONS INTERFACE

Embedded communication interfaces	- Ethernet 10/100/1000 Mbit/s: TCP/IP, UDP, FTP and Fieldbus PROFINET IO, Ethernet IP, Modbus TCP - Serial RS232/RS422FD up to 115.2 Kbit/s + Serial Aux RS232 up to 115.2 Kbit/s - OPC UA
Reader Networking	Datalogic ID-NET™
Connectivity Modes	Pass Through, Master/Slave, Ethernet point to point

INPUTS AND OUTPUTS

Digital Inputs	2 inputs opto-coupled and polarity insensitive Max. Voltage 30 Vdc Max. Input Current 10 mA
Digital Outputs	3 Outputs: configurable NPN, PNP and PP short-circuit protected VOUT (ILOAD = 0 mA) max. 24 Vdc VOUT (ILOAD = 100 mA) max. 3 Vdc ILOAD max. 100mA Using CBX connection box the first 2 outputs are opto-coupled

USER INTERFACE AND PROGRAMMING

Aiming System	Laser cross red projection aiming
User Interface	<ul style="list-style-type: none"> Configurable 360 degree multicolor visual feedback Green spot and Red spot LEDs X-PRESS™ Human Machine Interface Beeper X-PRESS™ Push Button 7 LEDs (Status, Communication, Trigger, Good Read, Ready, Power on, Network) Web Monitoring and Web Supervisory Interface
Device Programming	DL.CODE™ Windows-based software (programming via Ethernet or Serial Interface) with Javascript output formatter Serial Host Mode programming X-PRESS™ Human Machine Interface

ELECTRICAL FEATURES

Power Supply Voltage	24 VDC ± 10%
Max Power Consumption	STS320-XX3 3,1A Max STS320-XX4 4,1A Max STS320-XX5 5,1A Max STS320-XX6 6,0A Max

360 DEGREE VISUAL FEEDBACK DEFAULT COLORS

Default configuration	LEDs COLOR
Good Read	Green
No Read	Red
Configuration	Blue

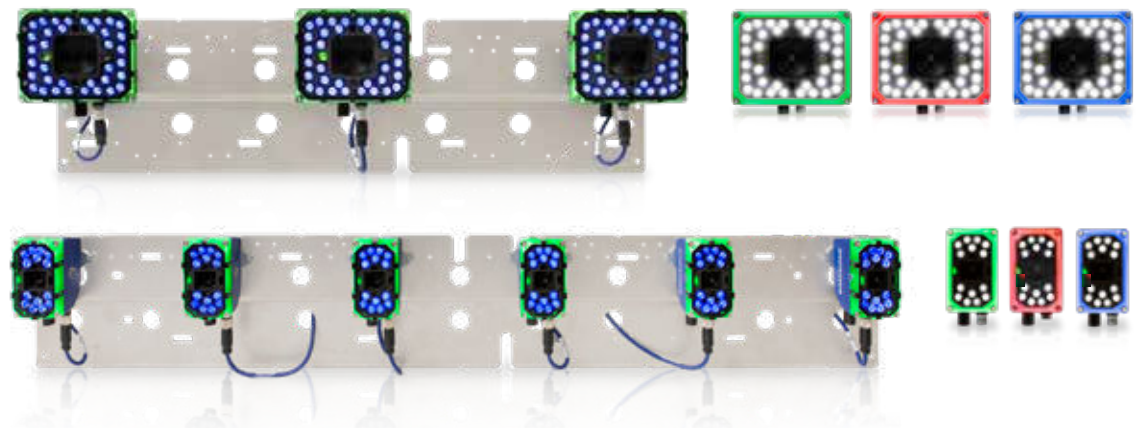

PHYSICAL FEATURES

Dimensions	STS320-003, STS320-013, STS320-014, STS320-203 695 x 177 x 119.1 mm [27.36 x 6.97 x 4.69 in] STS320-113 695 x 181.5 x 133.9 mm [27.36 x 7.15 x 5.27 in] STS320-103, STS320-114 726 x 181.5 x 133.9 mm [28.58 x 7.15 x 5.27 in] STS320-204 815 x 177 x 119.5 mm [32.09 x 6.97 x 4.64 in] STS320-004, STS320-015, STS320-016, STS320-205 1095 x 177 x 119.1 mm [43.11 x 6.97 x 4.69 in] STS320-104, STS320-115 1095 x 181.5 x 133.9 mm [43.11 x 7.15 x 5.27 in] STS320-116 1126 x 181.5 x 133.9 mm [44.33 x 7.15 x 5.27 in]
Weight	STS320-003, STS320-013, STS320-203: 4.84 Kg (10.67 lbs) STS320-103, STS320-113: 5.68 Kg (12.52 lbs) STS320-014: 5.54 Kg (12.21 lbs) STS320-114: 6.68 Kg (14.73 lbs) STS320-204: 6.16 Kg (13.58 lbs) STS320-004: 7.44 Kg (16.40 lbs) STS320-104: 8.58 kg (18.92 lbs) STS320-015, STS320-205: 8.12 Kg (17.90 lbs) STS320-115: 9.55 Kg (21.04 lbs) STS320-016: 8.80 Kg (19.40 lbs) STS320-116: 10.51 Kg (23.17 lbs)
Case Material	Aluminium case and plastic protective window cover

ENVIRONMENTAL FEATURES

Humidity	90% non condensing
Protection Class EN60529	IP65 and IP67
Operating Temperature	-10 to 50°C (14 to 122°F)
Storage Temperature	-20 to 70 °C (-4 to 158 °F)
Sulfur gas resistance	Available for all the models according to ISO EN 60068-2-43

SAFETY & REGULATORY

Agency approvals	The product meets necessary safety and regulatory approvals for its intended use.
Environmental compliance	Complies to EU RoHS
Regulatory	EN61000-6-2 Electromagnetic Immunity; EN61000-6-4 Electromagnetic Emissions Class A; FCC part 15 for Class A digital device; CSA listed product for Canada and U.S.; CE; KC
Laser Safety	Class 1 Laser Product but may be marked as Class 2 Laser Product as worse case as per IEC 60825-1 Complies with CDRH Requirements
LED Safety	LED Safety (Risk Group 1) as per EN 62471

WARRANTY

Warranty	2-Year Factory Warranty
-----------------	-------------------------

DIMENSIONS

STS320-003

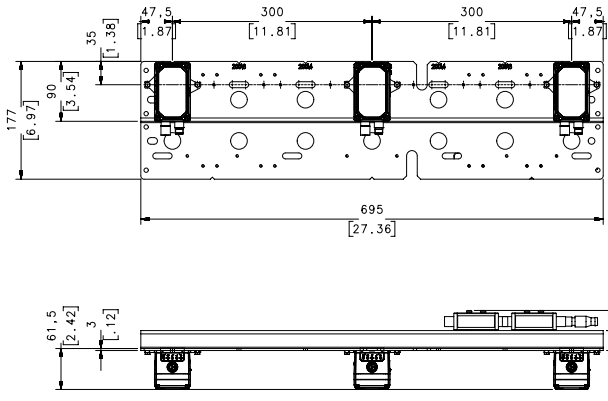

STS320-004

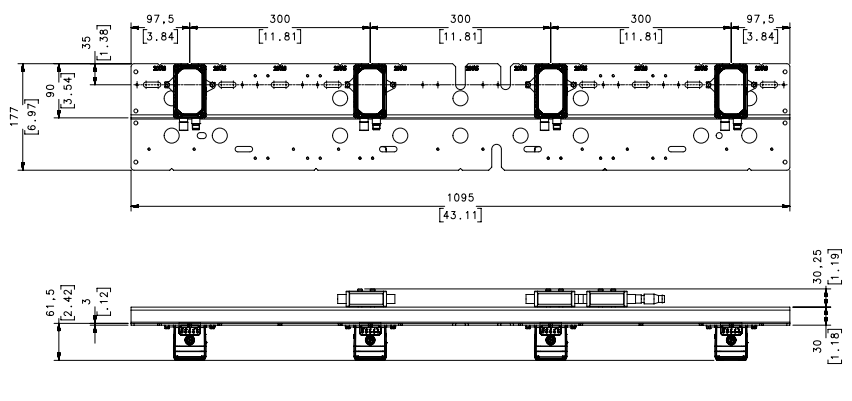

STS320-013

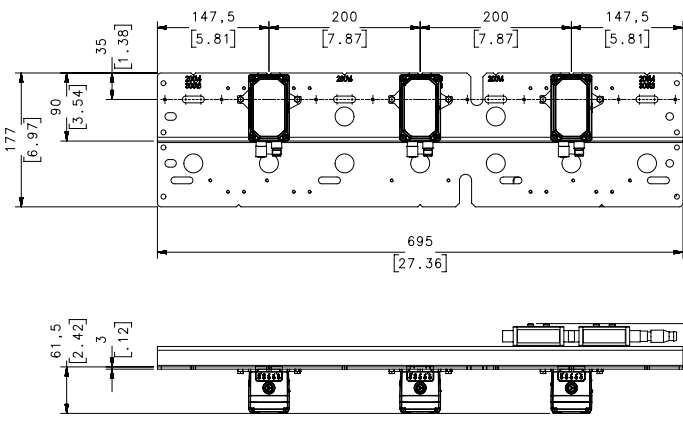

STS320-014

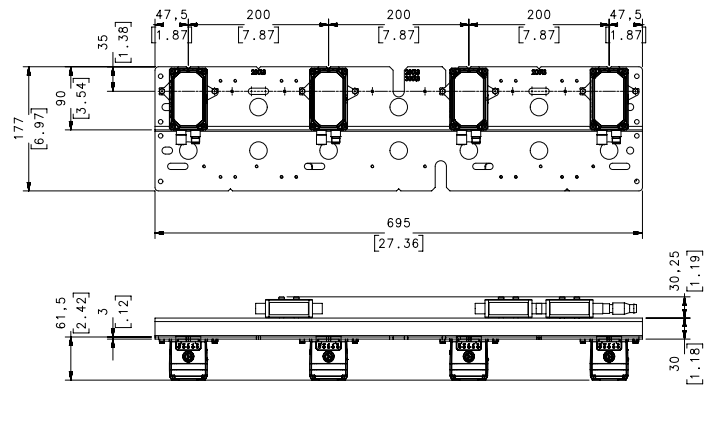

STS320-015

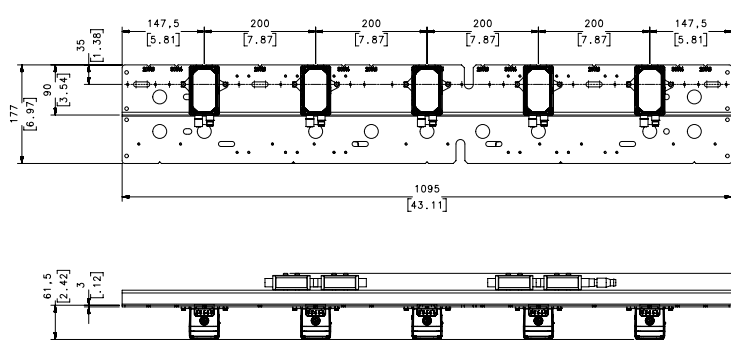

STS320-016

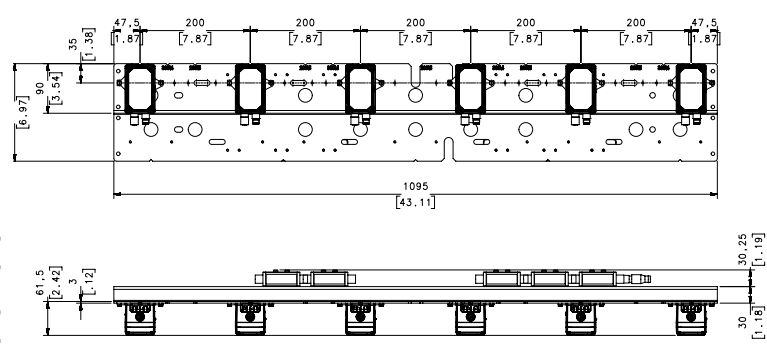

STS320-103

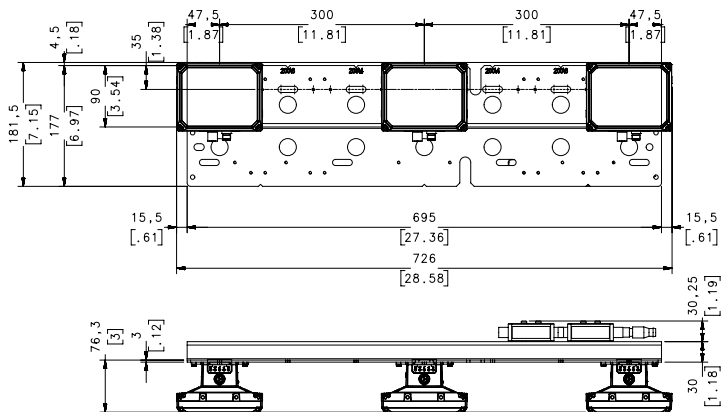

STS320-104

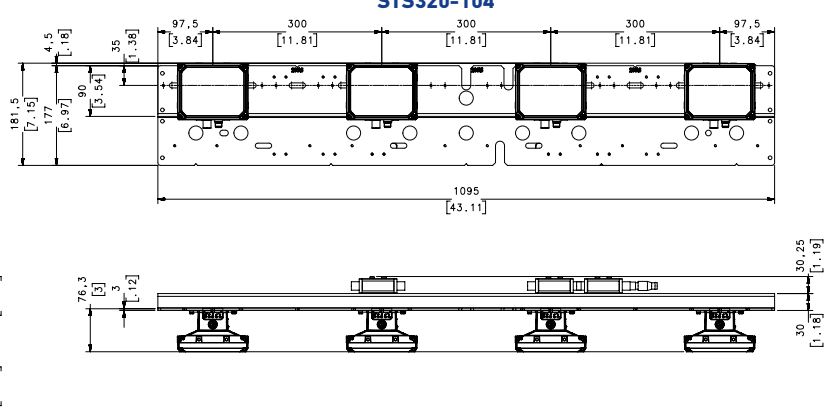

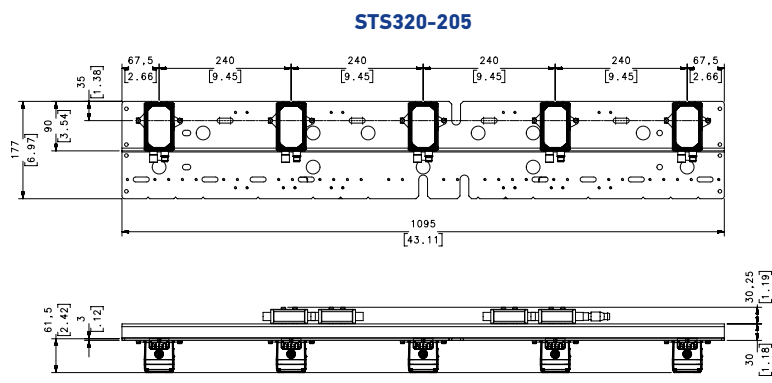
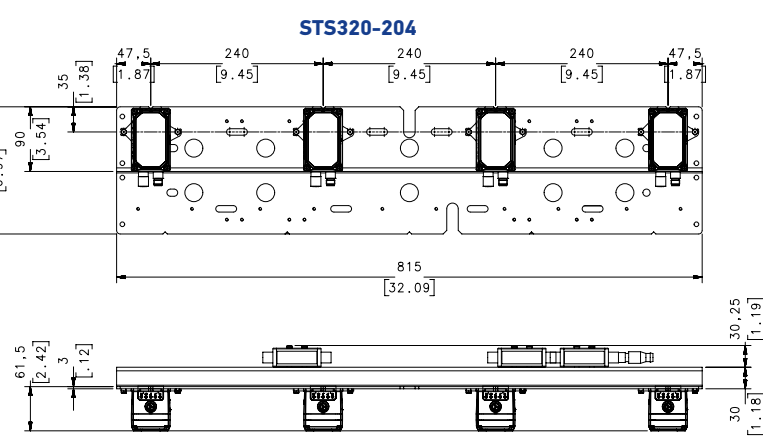
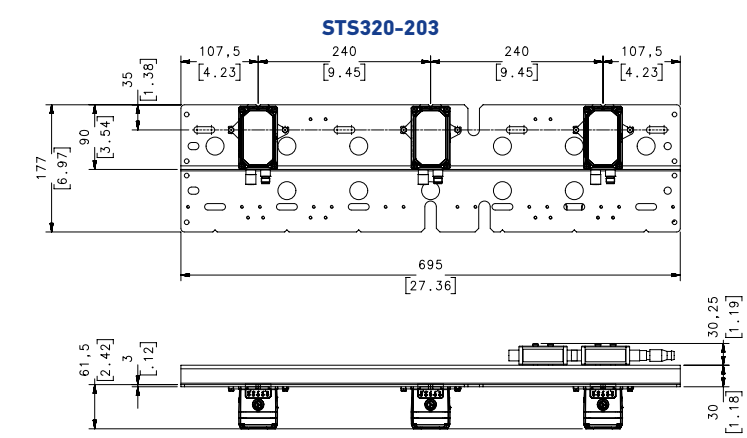
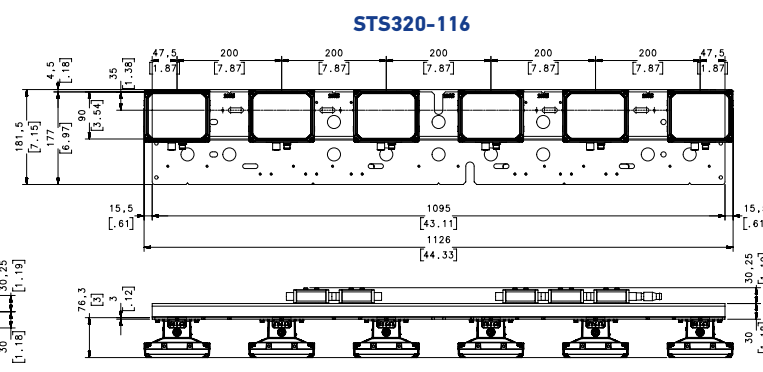
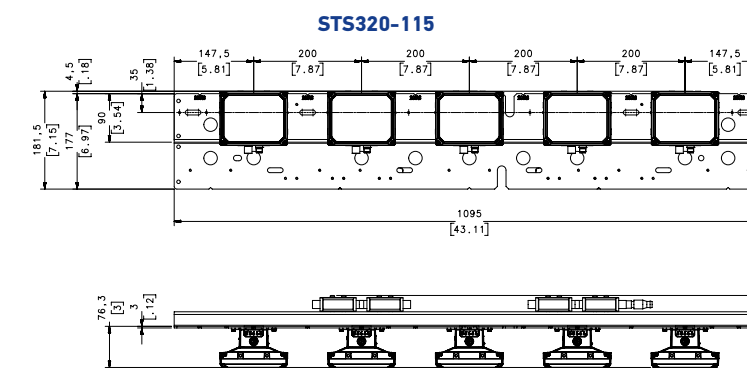
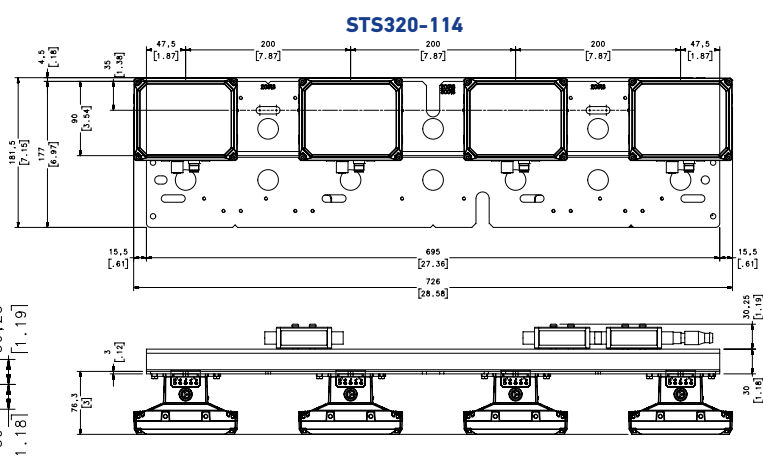
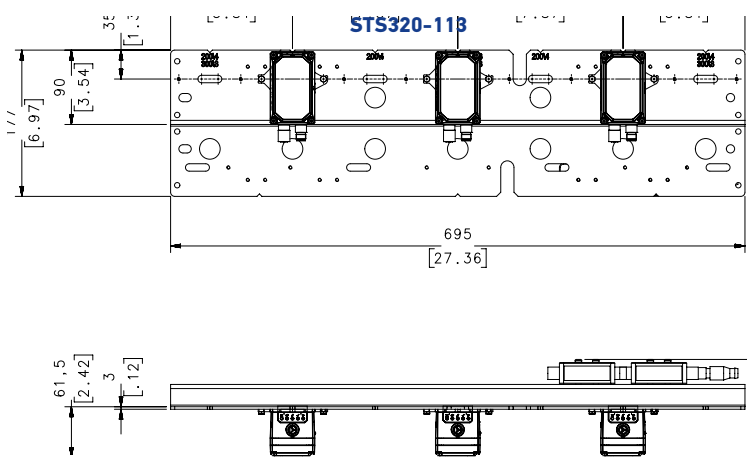

Dimensions in mm

MODELS

P/N	DESCRIPTION	READER QTY	CODE RESOLUTION	READING WIDTH	DOF	MIN READING DISTANCE	MAX READING DISTANCE	FOCUS DISTANCE	VERTICAL FOV @ MIN DISTANCE
STS320-00X AND STS320-01X STANDARD RANGE TOP READING PASSENGER LIGHT TRUCK TIRES									
STS320			mm (mils)	mm (in)	mm (in)	mm (in)	mm (in)	mm (in)	mm (in)
938100001	STS320-003 TIRE SORT 3_HEAD ST RES	3	0.30 (12)	950 (37.40)	250 (9.84)	830 (32.68)	1080 (42.52)	940 (37.01)	202 (7.95)
938100002	STS320-004 TIRE SORT 4_HEAD ST RES	4		1250 (49.21)					
938100004	STS320-013 TIRE SORT 3_HEAD HI RES	3	0.25 (10)	650 (25.59)		620 (24.41)	870 (34.25)	730 (28.74)	152 (5.98)
938100005	STS320-014 TIRE SORT 4_HEAD HI RES	4		850 (33.46)					
938100006	STS320-015 TIRE SORT 5_HEAD HI RES	5		1050 (41.34)					
938100007	STS320-016 TIRE SORT 6_HEAD HI RES	6		1250 (49.21)					
MATRIX 320 ATS ASSEMBLY FOR TIRES SOLUTIONS			mm (mils)	mm (in)		mm (in)	mm (in)	mm (in)	mm (in)
938100036	MATRIX 320 ATS-000 ASSY FOR STS320-00X	-	0.30 (12)	359 (14.13)	250 (9.84)	830 (32.68)	1080 (42.52)	940 (37.01)	202 (7.95)
938100037	MATRIX 320 ATS-010 ASSY FOR STS320-01X	-	0.25 (10)	270 (10.63)		620 (24.41)	870 (34.25)	730 (28.74)	152 (5.98)
STS320-10X AND STS320-11X LONG RANGE TOP READING COMMERCIAL VEHICLE TIRES									
STS320			mm (mils)	mm(in)	mm(in)	mm(in)	mm(in)	mm(in)	mm(in)
938100008	STS320-103 TIRE SORT 3_HEAD ST RES LR	3	0.35 (14)	950 (37.40)	400 (15.75)	850 (33.46)	1250 (49.21)	1000 (39.37)	211 (8.31)
938100009	STS320-104 TIRE SORT 4_HEAD ST RES LR	4		1250 (49.21)					
938100010	STS320-113 TIRE SORT 3_HEAD HI RES LR	3	0.25 (10)	650 (25.59)		830 (32.68)	1230 (48.43)	970 (38.19)	145 (5.71)
938100011	STS320-114 TIRE SORT 4_HEAD HI RES LR	4		850 (33.46)					
938100012	STS320-115 TIRE SORT 5_HEAD HI RES LR	5		1050 (41.34)					
938100013	STS320-116 TIRE SORT 6_HEAD HI RES LR	6		1250 (49.21)					
MATRIX 320 ATS ASSEMBLY FOR TIRES SOLUTIONS			mm (mils)	mm(in)		mm(in)	mm(in)	mm(in)	mm(in)
938100038	MATRIX 320 ATS-100 ASSY FOR STS320-10X	-	0.35 (14)	375 (14.76)	400	850 (33.46)	1250 (49.21)	1000 (39.37)	211 (8.31)
938100039	MATRIX 320 ATS-110 ASSY FOR STS320-11X	-	0.25 (10)	258 (10.16)	(15.75)	830 (32.68)	1230 (38.19)	970 (38.19)	145 (5.71)
STS32-20X - NEAR RANGE AND BOTTOM READING TIRES									
938100014	STS320-203 TIRE SORT 3_HEAD ST RES NR	3	0.30 (12)	770 (30.31)	170 (6.69)	280 (11.02)	450 (17.72)	330 (12.99)	157 (6.18)
938100015	STS320-204 TIRE SORT 4_HEAD ST RES NR	4		1010 (39.76)					
938100016	STS320-205 TIRE SORT 5_HEAD ST RES NR	5		1250 (49.21)					
MATRIX 320 ATS ASSEMBLY FOR TIRES SOLUTIONS			mm (mils)	mm (in)	mm (in)	mm (in)	mm (in)	mm (in)	mm (in)
938100040	MATRIX 320 ATS-200 ASSY FOR STS320-20X	-	0.30 (12)	300 (11.81)	170 (6.69)	280 (11.02)	450 (17.72)	330 (12.99)	157 (6.18)

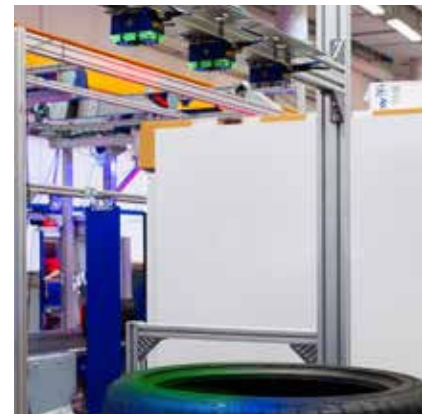
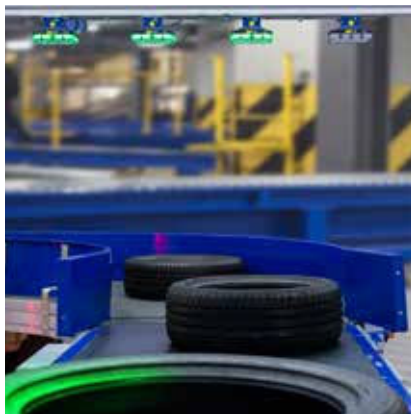
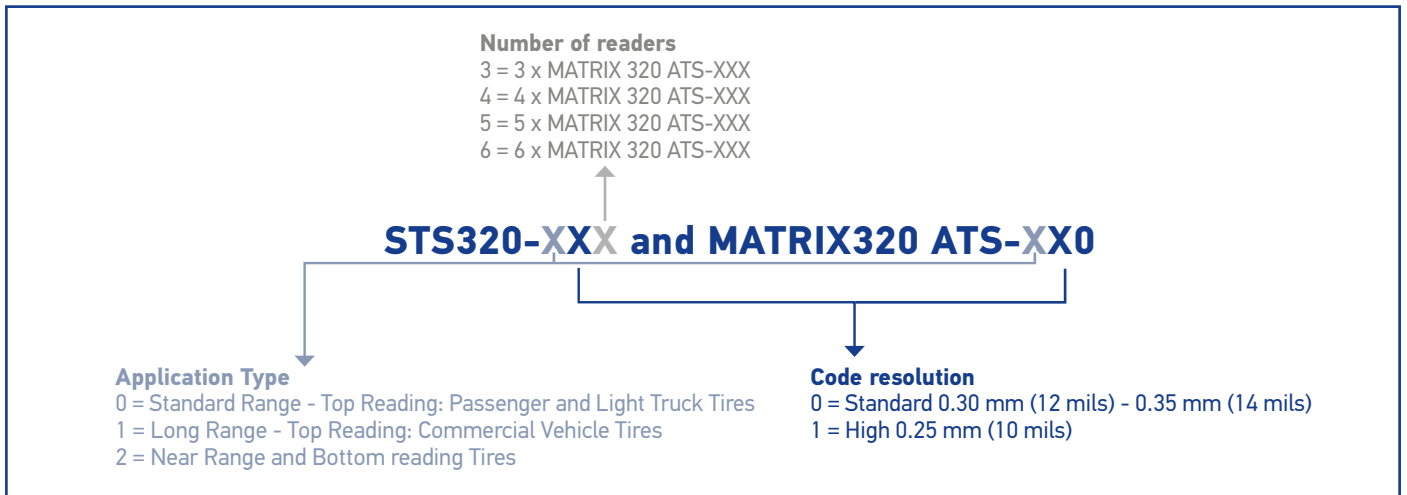

ACCESSORIES

CATEGORY	P/N	DESCRIPTION
Power Supply	93ACC0264	PWR-240 POWER UNIT 110/230VAC 24V 240 W
Cover	93ACC0323	Cover LT 14L STS320/ATS320
	93ACC0324	Cover LT 36L STS320/ATS320
Cables	93A050058	M12-IP67 Cable To CBX or QL (1M)
	93A050059	M12-IP67 Cable To CBX or QL (3M)
	93A050060	M12-IP67 Cable To CBX or QL (5M)
	93A051390	M12-IP67 Cable To CBX or QL (10M)
	93A050122	M12-IP67 GIGA Ethernet Cable X-Coded (1M)
	93A050123	M12-IP67 GIGA Ethernet Cable X-Coded (3M)
	93A050124	M12-IP67 GIGA Ethernet Cable X-Coded (5M)
	93A050124	M12-IP67 GIGA Ethernet Cable X-Coded (5M)
Ethernet Switch	93ACC1842	ETH GB SWITCH 8 CH 24Vdc
Software Management	93A101027	WEBSSENTINEL PLUS LICENSE IMAGES 5 ARRAYS
	93A101028	WEBSSENTINEL PLUS LICENSE IMAGES 10 ARRAYS
	93A101029	WEBSSENTINEL PLUS LICENSE IMAGES 20 ARRAYS
	93A101030	WEBSSENTINEL PLUS LICENSE IMAGES 32 ARRAYS
	93A101031	WEBSSENTINEL PLUS LICENSE IMAGES 64 ARRAYS



WebSentinel Plus

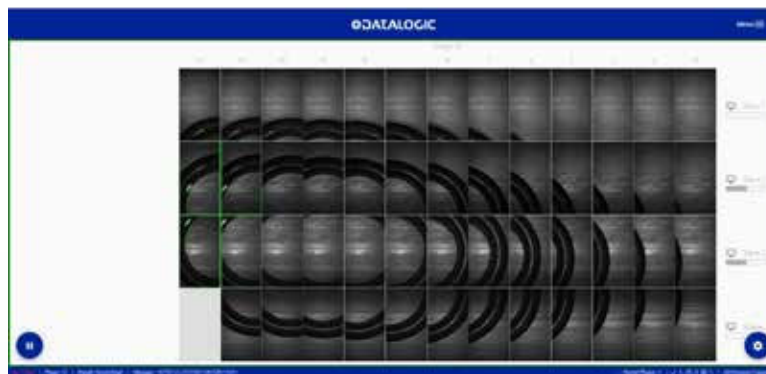

Mosaic view