

Datalogic S.r.l.
 Via San Vitalino 13
 40012 Calderara di Reno (BO)
 Italy
 Tel. +39 051 3147011
 Fax +39 051 3147205
 ©2014-2023 Datalogic S.p.A. and/or its affiliates

All rights reserved. Without limiting the rights under copyright, no part of this documentation may be reproduced, stored in or introduced into a retrieval system, or transmitted in any form or by any means, or for any purpose, without the express written permission of Datalogic S.p.A. and/or its affiliates.

Owners of Datalogic products are hereby granted a non-exclusive, revocable license to reproduce and transmit this documentation for the purchaser's own internal business purposes. Purchaser shall not remove or alter any proprietary notices, including copyright notices, contained in this documentation and shall ensure that all notices appear on any reproductions of the documentation.

Electronic versions of this document may be downloaded from the Datalogic website (www.datalogic.com). If you visit our website and would like to make comments or suggestions about this or other Datalogic publications, please let us know via the "Contact" page.

Disclaimer

Datalogic has taken reasonable measures to provide information in this manual that is complete and accurate, however, Datalogic shall not be liable for technical or editorial errors or omissions contained herein, nor for incidental or consequential damages resulting from the use of this material. Datalogic reserves the right to change any specification at any time without prior notice.

Trademarks

Datalogic and the Datalogic logo are registered trademarks of Datalogic S.p.A. in many countries, including the U.S.A. and the E.U.

SUPPORT THROUGH THE WEBSITE

Datalogic provides several services as well as technical support through its website.

Log on to www.datalogic.com.

For quick access, from the home page click on the search icon , and type in the name of the product you're looking for. This allows you access to download Data Sheets, Manuals, Software & Utilities, and Drawings.

Hover over the Support & Service menu for access to Services and Technical Support.

SAFETY PRECAUTIONS

READ THIS INFORMATION BEFORE INSTALLING THE PRODUCT!

This product is intended to be installed by Qualified Personnel only.

The power supplied to the CBX510 from the data collecting device must be between 10 and 30 Vdc only, typically it is 24 Vdc.



CAUTION: CBX510 only accepts power directly from the data collecting device connected through the 25-pin connector. This allows passing power to connected accessories such as Encoder/Tach and Presence Sensor/Trigger from SC5000 or DS8110/DX8210 scanners powered directly. See the relative data collecting device Reference Manual for details.



CAUTION: +V and -V signals must not be used as power supply inputs to the CBX510 nor to the data collecting device.



NOTE: To avoid electromagnetic interference: Connect the data collecting device chassis to earth ground through the jumper, Connect the Cable Shields to the Shield spring clamp connectors.



©2014 - 2023 Datalogic S.p.A. and/or its affiliates
 • All rights reserved • Without limiting the rights under copyright, no part of this documentation may be reproduced, stored in or introduced into a retrieval system, or transmitted in any form or by any means, or for any purpose, without the express written permission of Datalogic S.p.A. and/or its affiliates • Datalogic and the Datalogic logo are registered trademarks of Datalogic S.p.A. in many countries, including the U.S. and the E.U.

www.datalogic.com



821002654 (Rev. D) April 2023

OVERVIEW

The CBX510 is a connection box which can be used as an accessory to facilitate system connections for installation and device replacement of several Datalogic family data collecting devices.

System cabling is made through spring clamp terminal blocks inside the CBX510 while the data collecting device is connected to the CBX510 through a 25-pin connector on the housing.

A 9-pin connector placed inside the CBX510 facilitates connection between an external PC and the auxiliary serial interface of the data collecting device for data monitoring.

CBX510 can also house an accessory Backup and Restore Module to make system maintenance extremely quick and easy.

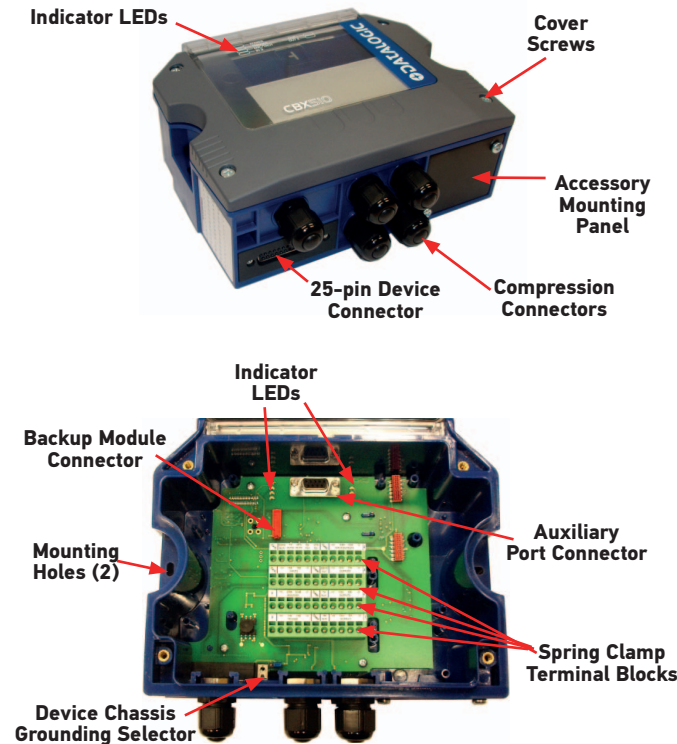

POWER CONSUMPTION NOTE

Total power consumption is given by adding the CBX510 power consumption to that of all the devices powered through the CBX510 (BM100 Backup Module, Trigger, Encoder/Tach, I/O). Refer to the example below and the manual of the connected devices for details about minimum/maximum supply voltage and power consumption.

The following example shows current consumption for the most common system devices being powered through the CBX510.

Example:

Data Collecting device = DS8110: sourcing 24 Vdc power

For CBX510, a typical power consumption of about 360 mA @ 24 Vdc includes the following devices:

- LEDs (all on)
- Output 1 (sourcing 40 mA max continuous current)
- Trigger
- Output 2 (sourcing 40 mA max continuous current)
- Encoder
- BM100

SUPPORTED DATA COLLECTING/POWER SOURCING DEVICES

The CBX510 can be directly connected to the following data collecting devices through the 25-pin connector.

Cameras	Scanners	Dimensioner	Controllers
AV7000	DS8110	DM3610	SC5000
AV500/AV900	DX8210		SC5100

OPENING THE CBX510

To install the CBX510 or during normal maintenance, it is necessary to open it by unscrewing the four cover screws:



CAUTION: The CBX510 must be disconnected from the power supply during this operation (25-pin connector disconnected.)

MECHANICAL INSTALLATION

CBX510 can be mounted to various wooden or plastic surfaces using the two self-threading screws (3.9 x 45 mm) and washers provided in the package.

Mounting to other surfaces such as concrete walls or metallic panels requires user-supplied parts (screws, screw anchors, nuts, etc). A mounting template is included in the package to facilitate hole drilling alignment.

The following accessories are available for mounting CBX510 to a DIN rail using BA100 (93ACC1821), a Bosch Frame using BA200 (93ACC1822).

The diagram below gives the overall dimensions of the CBX510 and shows the two mounting through-holes.

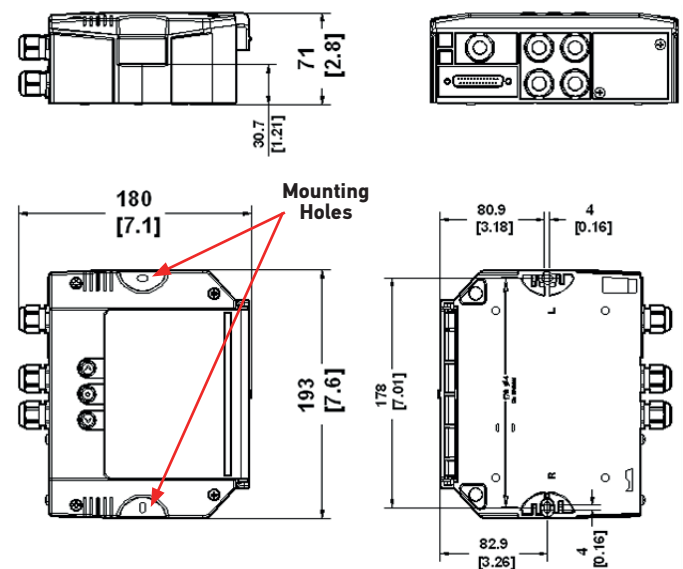

ACCESSORIES

The following accessories are available on request for the CBX510:

BM100	Backup Module	93ACC1808
BA100	DIN Rail Mounting Kit	93ACC1821
BA200	Bosch Frame Mounting Kit	93ACC1822
BA300	M12 3PF Service Conn. (Aux port)	93ACC1877
BA500	M12 4PF Trigger Connector	93ACC1854
BA900	2 Cable Compression Conn. Panel	93ACC1847
CAB-DS01-S	I/O Cable M12-17-p to 25-p D-sub 1m	93A050058
CAB-DS03-S	I/O Cable M12-17-p to 25-p D-sub 3m	93A050059
CAB-DS05-S	I/O Cable M12-17-p to 25-p D-sub 5m	93A050060
CAB-SC500	Cable SC500 to CBX510 1m	93A050059

LAYOUTS

The following figures show typical layouts.

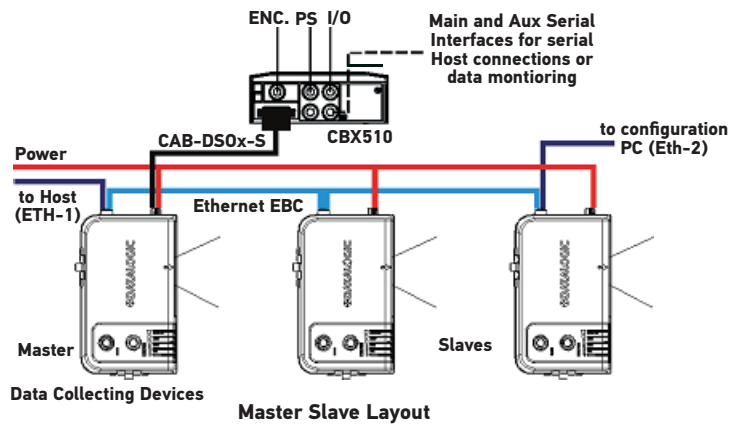
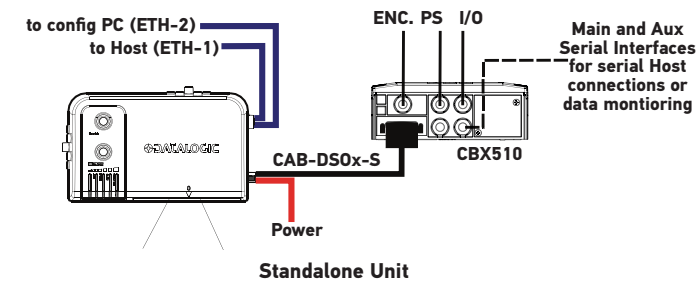

After making system cabling, connect a compatible device to the CBX510's 25-pin Device Connector through a proper cable. Power on the compatible device. The CBX510 Power LED turns on (blue) when the power connection has the correct polarity. In case of wrong polarity, no power is passed to the CBX510 and the Power LED remains off.

In typical layouts, the data collecting devices (Master or Standalone) are connected in an Ethernet network to a Host through an Ethernet switch.

The Master or Standalone device is also connected to the CBX510 where it receives Presence Sensor (Trigger) and Encoder signals. Output devices connected to the CBX510 can be driven by the device.

Optionally, connections to a Serial Host can be made through the CBX510 using either the Main or Aux Serial Interfaces.

After system functioning has been verified, close the CBX510 using the four cover screws

SYSTEM WIRING

The connection and wiring procedure for CBX510 is described as follows:

1. Verify that the CBX510 25-pin connector is free (no connection).
2. Open the CBX510 by unscrewing the four cover screws.
3. Unscrew the compression connectors and pass all the system cables through them into the CBX510 housing.
4. To connect the input/output signals:
 - Prepare the individual wires of the system cables by stripping the insulation back approximately 1 cm.
 - Using a device such as a small screwdriver, push down on the internal lever directly above the clamp (circular hole).
 - Insert the wire into the clamp (circular hole) and release the internal lever. The wire will now be held in the spring clamp.
5. Tighten the compression connector nuts so that the internal glands seal around the cables.



Flexible stranded wire should be used and must meet the following specifications.

All positions: 24 - 16 AWG 0.2 - 1.5 mm²

The CBX510 spring clamp connector pinouts are indicated in the Pinout table. Refer to the data collecting device Installation Manual for signal details.

Pinouts		
Group	Name	Function
Grounding	Earth	Protection Earth Ground (PE)
	+V	I/O Power Source
I/O Power	-V	I/O Power Reference
	I1A	External Trigger A (polarity insensitive)
Trigger/PS Input	I1B	External Trigger B (polarity insensitive)
	ENA	Encoder A (polarity insensitive)
Encoder/Tach Input	ENB	Encoder B (polarity insensitive)
	I3A	Input 3A (polarity insensitive)
Generic Input	I3B	Input 3B (polarity insensitive)
	O1+	Output 1 +
Generic Outputs	O1-	Output 1 -
	O2+	Output 2 +
	O2-	Output 2 -
	O3+	Output 3 + (only for SC5000)
Other I/O	O3-	Output 3 - (only for SC5000)
	IO4+	Programmable Input/Output 4+ (only for SC5000)
	IO4-	Programmable Input/Output 4- (only for SC5000)
	TX	Auxiliary Interface TX
Auxiliary Interface	RX	Auxiliary Interface RX
	SGND	Auxiliary Interface Reference
	Shield	Cable Shields (internally connected to PE)
Main Interface		RS232
		TX
		RTS
		RX
		CTS
		SGND**
		RS422/485 FD
		TX+
		TX-
		*RX+
		*RX-
		SGND**

*Do not leave floating. see Data Collecting Device Reference Manual for connection details.
**When connected to SC5000 the Main SGND is opto-isolated.

SHIELD TO PROTECTION EARTH

All I/O device and Serial Host Interface cable shields can be connected to Earth ground (PE) by inserting them into any one of the CBX510 Shield clamp connectors.

CHASSIS GROUNDING JUMPER SETTINGS

The data collecting device chassis grounding method can be selected by positioning a jumper. In this way the data collecting device chassis can be connected to earth ground (only if pin Earth is connected to a good earth ground). For DS8110 and DX8210, the chassis is internally connected to the scanner GND.

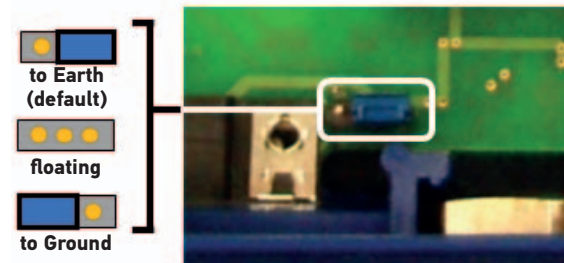

MAIN AND AUXILIARY SERIAL INTERFACES

Connections to a Serial Host (if permanent), should be made through the CBX510 using either the Main or Aux Serial Interface internal spring clamp connectors.

Instead, for data monitoring, the data collecting device auxiliary serial interface can be connected temporarily to a portable PC through the internal CBX510 9-pin connector.

This connection can be made to a PC using a straight through cable or a USB-RS232 converter.

See the data collecting device Installation Manual and Help On Line for more details.

The details of the connector pins are indicated in the following table:

CBX510 9-pin D-Sub Female Connector Pinout			
Pin	Name	Function	
2	TX	Auxiliary RS232	
3	RX	Auxiliary RS232	
5	SGND	Auxiliary Reference Ground	
1,4,6,7,8,9		N.C.	

BM100 BACKUP AND RESTORE MODULE (ACCESSORY)

The BM100 Backup and Restore Module (separate accessory) provides configuration parameter backup. It can easily be installed by aligning it over its corresponding connector in the CBX510 and pushing down until correctly seated.

When closed, the plastic support inside the CBX510 cover holds the module in place. For further details see the BM100 manual.

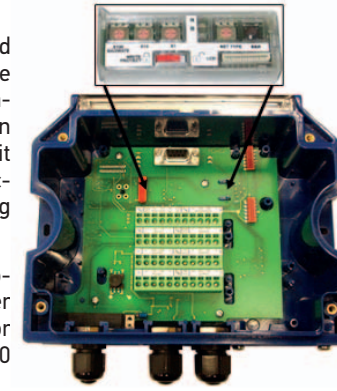

NOTE: All-in one models come with BM100 pre-installed

INDICATOR LEDS



There are six Indicator LEDs which signal power and I/O activity and are visible from the CBX510 outside cover.

The Power LED is blue when power is correctly applied to the CBX510. In case of wrong polarity, no power is passed to the CBX510 and the Power LED remains off. In this case the connected data collecting device and optional Backup Module are protected.



NOTE: All external I/O devices powered through CBX510 (connected to +V/-V), are protected from polarity inversion.

The remaining five LEDs signal activity on the relative I/O lines. Their meaning depends on the software configuration of the connected data collecting device.

TECHNICAL FEATURES

Electrical Features	
Supply Voltage	10 to 30 Vdc*
Consumption (See Power Consumption Note on opposite page)	0.5 A max.
Inputs 1, 2 and 3	Non opto-isolated polarity insensitive 30 Vdc max; 12 mA max
Outputs 1 and 2	Opto-isolated polarity sensitive 30 Vdc max; 40 mA max continuous 130 mA max pulsed
Output 3	Non opto-isolated Pass through
Input / Output 4	Non opto-isolated Pass through
User Interface	
LED Indicators	Power On (blue) TRIGGER (green) ENC/TACH (green) IN3 (green) OUT1 (yellow) OUT2 (yellow)

Physical Features	
Mechanical Dimensions	193 x 180 x 71 mm (7.6 x 7.1 x 2.8 in.)
Weight	about 800 g. (28.25 oz.)
Environmental Features	
Operating Temperature	0° to 50 °C (+32° to 122 °F)
Storage Temperature	-20° to 70° C (-4° to 158 °F)
Humidity max.	90% non condensing
Vibration Resistance EN 60068-2-6 2 hours on each axis	14 mm @ 2 to 10 Hz 1.5 mm @ 13 to 55 Hz 2 g @ 70 to 200 Hz
Shock Resistance EN 60068-2-27	30 g; 11 ms; 3 shocks on each axis
Protection Class EN 60529	IP65 (when compression connectors and reading device are correctly connected)

The features given are typical at a 25° C ambient temperature (if not otherwise indicated).
* for further details about minimum/maximum supply voltage refer to the manual of the connected reading device, since the minimum supply voltage required may be >10.

COMPLIANCE

This product is intended to be installed by Qualified Personnel only.

Power Supply

This device is intended to be supplied by a UL Listed or CSA Certified Power Unit with Class 2 or LPS power source, which supplies power directly through the 25-pin connector.

CE Compliance

European Declaration of Conformity

Hereby, Datalogic S.r.l. declares that the full text of the European Declaration of Conformity is available at: www.datalogic.com. Select the Support & Service > Downloads > Product Certifications link where you can search for your specific product certification.

UKCA Declaration of Conformity

Hereby, Datalogic S.r.l. declares that the full text of the UKCA Declaration of Conformity is available at: www.datalogic.com. Select the Support & Service > Downloads > Product Certifications link where you can search for your specific product certification.

Warning: This is a Class A product. In a domestic environment this product may cause radio interference in which case the user may be required to take adequate measures.

FCC Compliance

Modifications or changes to this equipment without the expressed written approval of Datalogic could void the authority to use the equipment.

This device complies with PART 15 of the FCC Rules. Operation is subject to the following two conditions: (1) This device may not cause harmful interference, and (2) this device must accept any interference received, including interference which may cause undesired operation.

This equipment has been tested and found to comply with the limits for a Class A digital device, pursuant to part 15 of the FCC Rules. These limits are designed to provide reasonable protection against harmful interference when the equipment is operated in a commercial environment. This equipment generates, uses, and can radiate radio frequency energy and, if not installed and used in accordance with the instruction manual, may cause harmful interference to radio communications. Operation of this equipment in a residential area is likely to cause harmful interference in which case the user will be required to correct the interference at his own expense.

EAC Compliance

Customs Union:

The CU Conformity certification has been achieved; this allows the Product to bear the Eurasian mark of conformity.