



Stroke-Turn Applicator

4214

for the following products

Family	Type
Stroke-Turn Applicator	4214L-200
	4214L-300
	4214L-400
	4214R-200
	4214R-300
	4214R-400

Edition: 06/2022 - Part.-No. 9003501

Copyright

This documentation as well as translation hereof are property of cab Produkttechnik GmbH & Co. KG.

The replication, conversion, duplication or divulgement of the whole manual or parts of it for other intentions than its original intended purpose demand the previous written authorization by cab.

Editor

Regarding questions or comments please contact cab Produkttechnik GmbH & Co. KG.

Topicality

Due to the constant further development of our products discrepancies between documentation and product can occur.

Please check www.cab.de for the latest update.

Terms and conditions

Deliveries and performances are effected under the General conditions of sale of cab.

Germany
cab Produkttechnik GmbH & Co KG
 Karlsruhe
 Phone +49 721 6626 0
www.cab.de

USA
cab Technology, Inc.
 Chelmsford, MA
 Phone +1 978 250 8321
www.cab.de/us

Taiwan
cab Technology Co., Ltd.
 Taipei
 Phone +886 (02) 8227 3966
www.cab.de/tw

Singapore
cab Singapore Pte. Ltd.
 Singapore
 Phone +65 6931 9099
www.cab.de/en

France
cab Technologies S.à.r.l.
 Niedermodern
 Phone +33 388 722501
www.cab.de/fr

Mexico
cab Technology, Inc.
 Juárez
 Phone +52 656 682 4301
www.cab.de/es

China
cab (Shanghai) Trading Co., Ltd.
 Shanghai
 Phone +86 (021) 6236 3161
www.cab.de/cn

South Africa
cab Technology (Pty) Ltd.
 Randburg
 Phone +27 11 886 3580
www.cab.de/za

1	Introduction	4
1.1	Instructions.....	4
1.2	Intended Use.....	4
1.3	Safety Instructions.....	4
1.4	Safety Marking	5
1.5	Environment.....	5
2	Product Description.....	6
2.1	Important Features.....	6
2.2	Technical Data.....	6
2.3	Overview Without Cover	7
2.4	Contents of Delivery.....	9
3	Operation	10
3.1	Standard Operation.....	10
3.2	Cleaning	10
3.3	Movement of the Pad.....	12
4	Error Messages	13
4.1	Error Messages of the Printer	13
4.2	Error Messages of the Applicator	13
5	Installation	14
5.1	Factory default Settings	14
5.2	Tools.....	14
5.3	Mounting and Dismounting the Cover.....	15
5.4	Transportation Lock.....	15
5.5	Mounting the Applicator to the Printer.....	16
5.6	Mounting the Pad.....	17
5.7	Mounting the Blow Tube.....	17
5.8	Connecting the Compressed Air	18
6	Adjustments	19
6.1	Adjusting the Pad.....	19
6.1.1	Moving the Pad in Y-Direction	20
6.1.2	Moving the Pad in Z-Direction	21
6.2.1	Moving the Pad in X-Direction.....	22
6.3	Set Throttle Valves on the Cylinders	23
6.4	Set the Sensors.....	23
6.5	Vacuum Adjustments.....	24
6.6	Adjusting the Blow Tube (Supporting Air).....	25
6.7	Adjustment of the Stopper for Blow Mode.....	27
6.8	Lift Speed of Cylinder Z.....	28
6.9	Sensors on Cylinder Z.....	29
6.10	End Position Cushioning.....	30
6.11	Adjusting the Options for Z-Direction Movement	30
6.12	Lift Speed of Cylinder R	31
6.13	Sensors on Cylinder R	31
6.14	Settings of the Rotation Angle of the Cylinder R	32
6.15	Labeling from Below - Changing the Spring of the Impact Sensor	33
7	Configuration.....	34
7.1	Method for Changing the Printer Setup.....	34
7.2	Configuration Parameters of the Applicator	35
7.3	Setting the Peel Position	36
7.4	Activation of Peel-off Mode	36
8	Test Operation	37
8.1	Test Mode without a Print Job.....	37
8.2	Test Mode with a Print Job.....	37
9	Drawings.....	38
9.1	Block Diagram.....	38
9.2	Pneumatic Drawing Type 4214	39
9.3	Pneumatic Drawing Type 4214 pressure reduced 4.5 bar	40
9.4	Labeling Position Type 4214 L	41
9.5	Label Position Type 4214 R	42
10	Index.....	43

1.1 Instructions

Important information and instructions in this documentation are designated as follows:



Danger!

Draws attention to an exceptionally great, imminent danger to your health or life due to hazardous voltages.



Danger!

Draws attention to a danger with high risk which, if not avoided, may result in death or serious injury.



Warning!

Draws attention to a danger with medium risk which, if not avoided, may result in death or serious injury.



Caution!

Draws attention to a danger with low risk which, if not avoided, may result in minor or moderate injury.



Attention!

Draws attention to potential risks of property damage or loss of quality.



Note!

Advice to make work routine easier or on important steps to be carried out.



Environment!

Gives you tips on protecting the environment.



Handling instruction



Reference to section, position, illustration number or document.



Option (accessories, peripheral equipment, special fittings).

Time

Information in the display.

1.2 Intended Use

- The device is manufactured in accordance with the current technological status and the recognized safety rules. However, danger to life and limb of the user or third parties and/or damage to the device and other tangible assets can arise during use.
- The device may only be used for its intended purpose and if it is in perfect working order, and it must be used with regard to safety and dangers as stated in the manual.
- The device is designed to use on a cab printer of the HERMES Q series. Any other use or use going beyond this shall be regarded as improper use. The manufacturer/supplier shall not be liable for damage resulting from unauthorized use; the user shall bear the risk alone.
- Usage for the intended purpose also includes complying with the manual, including the manufacturer's maintenance recommendations and specifications.



Note!

The complete and current version of the documentation can be found in the Internet.

1.3 Safety Instructions



Attention!

Initiation, adjustments and changing of parts are to be performed by qualified service personnel only.



Warning!

This is a class A product. In a domestic environment this product may cause radio interference in which case the user may be required to take adequate measures.

- Before mounting the delivered components disconnect the printer from the power supply and close the shutoff valve of the applicator.
- Only connect the device to other devices which have a protective low voltage.
- Switch off all affected devices (computer, printer, accessories) before connecting or disconnecting.
- In operation, moving parts are easily accessible.
This applies especially for the zone, where the pad is moved between the starting and the labelling position.
During operation do not reach into that zone and keep long hair, loose clothes, and jewelry away. Before any alterations are undertaken in those areas, close the compressed air shutoff valve.
- The device may only be used in a dry environment, do not expose it to moisture (water splashes, sprays and mist)
- Do not use the device in an explosive atmosphere.
- Do not use the device close to high-voltage power lines.
- Perform only those actions described in this manual.
Work going beyond this may only be performed by trained personnel or service technicians.
- Unauthorized interference with electronic modules or their software can cause malfunctions.
- Other unauthorized work on, or modifications to the device can also endanger operational safety.
- Always have service work done by a qualified workshop, where the personnel have the technical knowledge and tools required to do the necessary work.
- There are various warning stickers on the device. They draw your attention to danger. Warning stickers may therefore not be removed.

1.4 Safety Marking

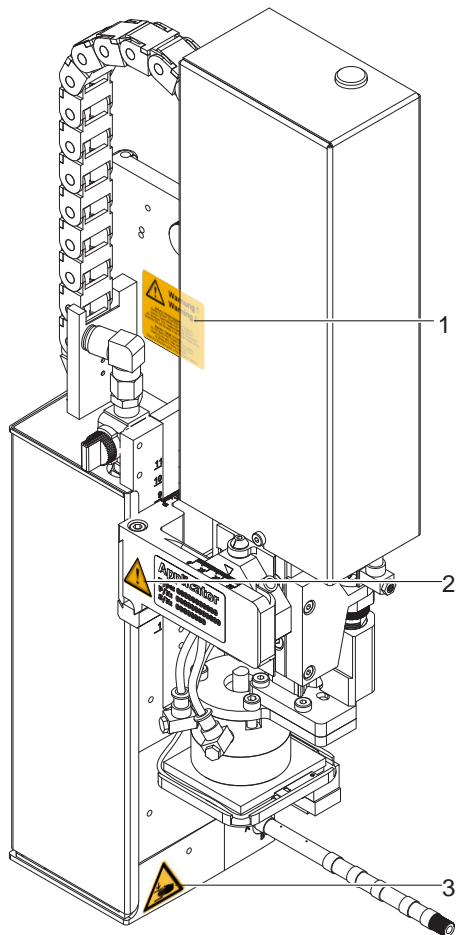

1:



Risk of injuries by moving parts!

2:

The cylinder is under pressure also if the printer is switched off.
Possibility of residual energy!

3:



Danger of crushing hands and fingers by the moving pad!



Attention!

Never remove or cover safety markings!
Replace it in case of damage!

Fig. 1 Safety marking

1.5 Environment



Obsolete devices contain valuable recyclable materials that should be sent for recycling.

- Send to suitable collection points, separately from residual waste.

The modular construction of the applicator enables it to be easily disassembled into its component parts.

- Send the parts for recycling.

2.1 Important Features

- The supporting air and the vacuum as well as the speed of the cylinder are adjustable. That way the applicator can be adapted to different label materials and sizes.
- To avoid contamination within the vacuum channels they are cleaned by air pressure impulse at the end of each application.
- For operation in a system the I/O interface of the printer can be used.

2.2 Technical Data

Label transfer method		Tamp pad	Tamp pad with foam	Tamp pad with label stop	Blow pad
		4214 L/R 11 F	4214 L/R 12 F	4214 L/R 61 F	4214 L/R 2100
Label width in mm for	HERMES Q2	4 - 58	10 - 58	10 - 58	10 - 58
	HERMES Q4	10 - 80	10 - 80	10 - 80	10 - 80
Label height in mm for	HERMES Q2	4 - 40	4 - 40	4 - 40	10 - 40
	HERMES Q4	8 - 40	8 - 40	8 - 40	10 - 40
Compressed air pressure		0,45 MPa (4,5 bar)			
Sound pressure level		unter 74 dB(A)			
Product during labeling	fixed	■	■	■	■
	in motion	-	-	-	■
Labeling onto the product	from the top	■	■	■	■
	from below	■	■	■	■
	sideways	■	■	■	■
Product height	fixed	-	-	-	■
	variable	■	■	■	-
Horizontal swing angle 90°, 180°, 0°		■	■	■	■
Product distance to lower edge					
at cylinder stroke	200 mm up to mm	135	135	135	140
	300 mm up to mm	235	235	235	240
	400 mm up to mm	335	335	335	340
Immersion depth pad F ²⁾	up to mm	65	65	65	-
Cycle time about frequency/min. ¹⁾		25	25	25	25

Table 1 Technical Data

¹⁾ Determined at 100 mm stroke below device / smallest label height / print speed 100 mm/s.

²⁾ Immersion depth at applicator >25 mm, the cover of the HERMES Q must be modified.

2.3 Overview Without Cover

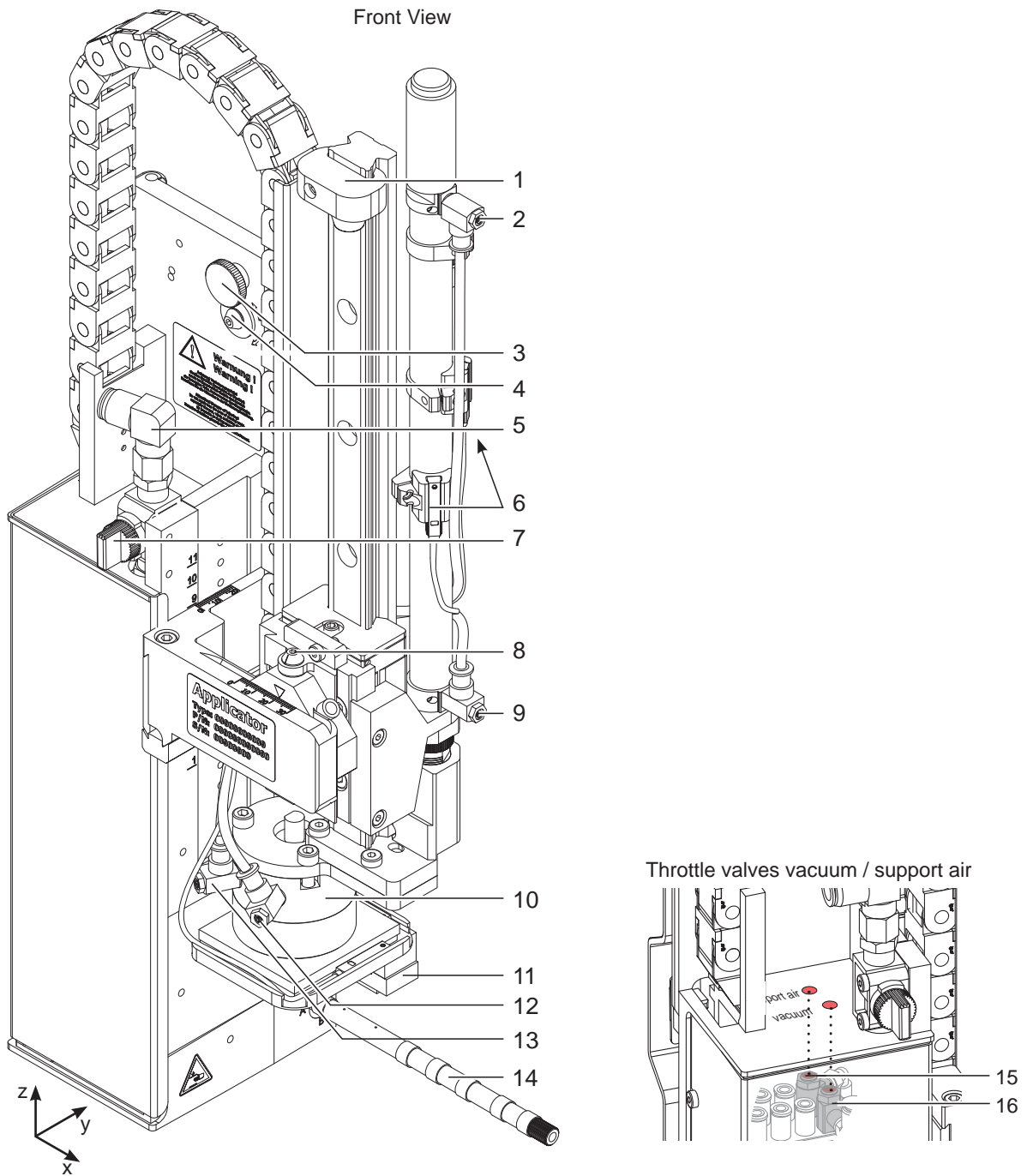

Fig. 2 Device overview - Front view

- | | |
|--|---|
| <ul style="list-style-type: none"> 1 Stopper for the operation mode "Blow on", transport lock 2 Throttle valve cylinder - move in Z-direction 3 Knurled screw for attaching the applicator to the printer 4 Setting screw to adjust the angle between applicator and printer 5 Compressed air connector 6 Sensors Middle Position Z-direction 7 Shutoff valve | <ul style="list-style-type: none"> 8 Setting screw for vertical adjustment cylinder assembly 9 Throttle valve cylinder - move out Z-direction 10 Cylinder R (Rotation) 11 Pad (customized) 12 Throttle valve cylinder R- move in 13 Throttle valve cylinder R- move out 14 Blow tube for supporting air 15 Support air throttle valve 16 Vacuum throttle valve |
|--|---|

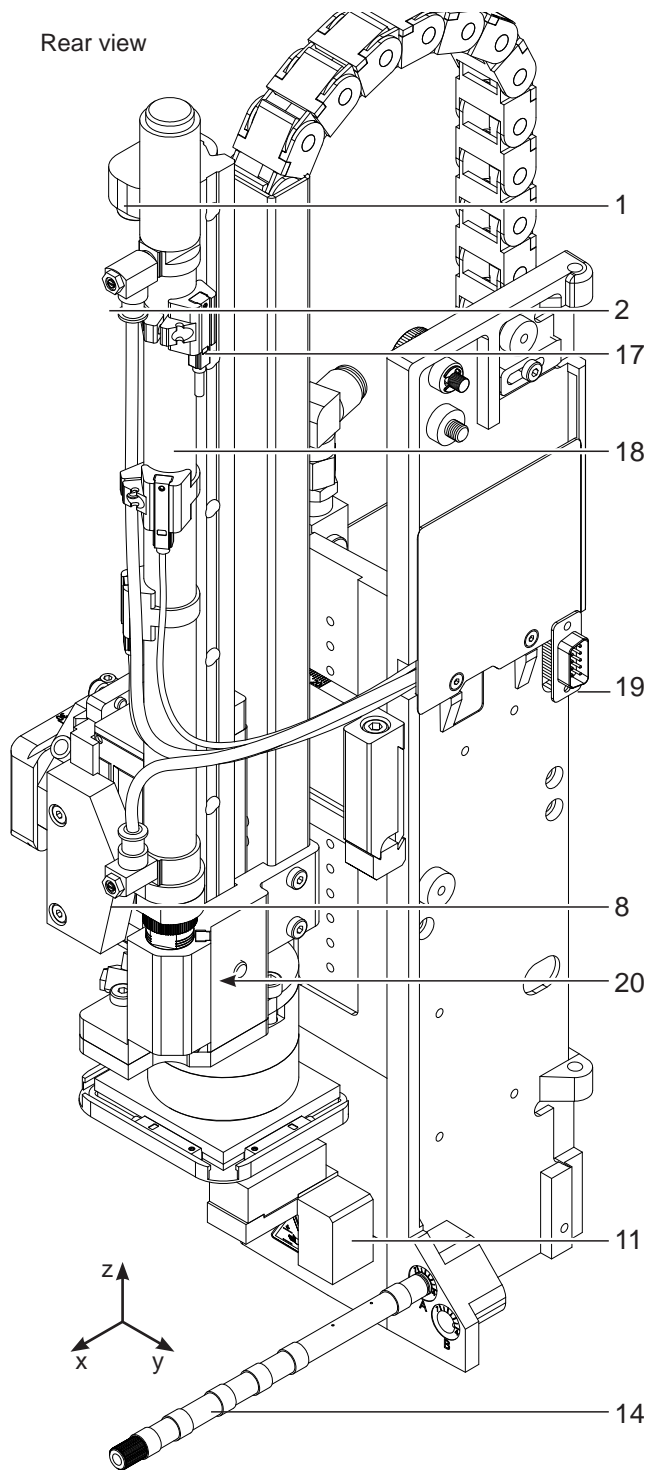

Fig. 3 Device overview - Rear view

- 1 Stopper for the operation mode "Blow on"/ transport lock
- 2 Throttle valve cylinder - move in Z-direction
- 8 Throttle valve cylinder - move out Z-direction
- 11 Pad (customized)
- 17 Sensor "start position" Cyl. Z
- 18 Cylinder Z
- 19 Interface to the printer
- 20 Sensor "end position" Cyl. Z

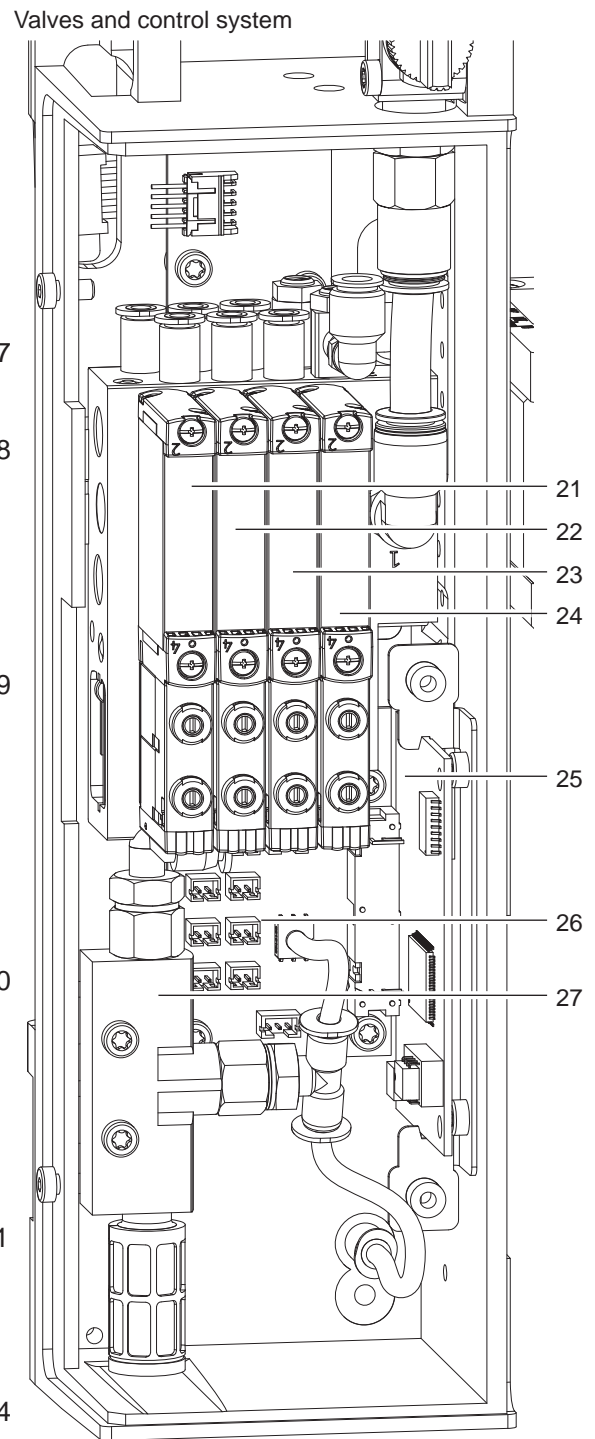
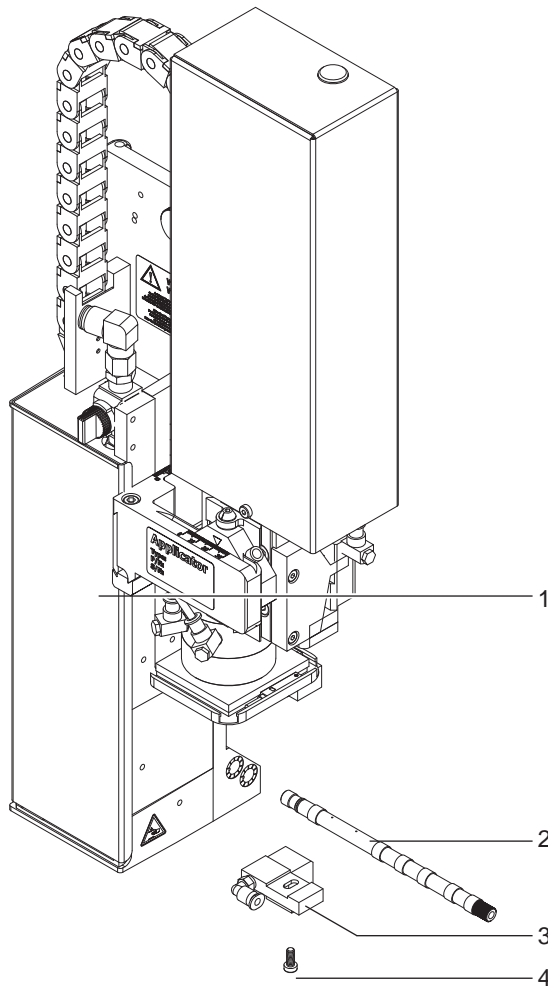

Fig. 4 Device overview - Control system

- 21 Valve Cylinder Z
- 22 Valve Cylinder R
- 23 Valve Blow air
- 24 Valve Vacuum and Support air
- 25 PCB Applicator Control
- 26 PCB Applicator Interfaces
- 27 Vacuum Generator

2.4 Contents of Delivery



- Applicator (1)
- Blow tube - as ordered (2)
- Pad - as ordered (3)
- Screws as part of the pad (4)
- Documentation

Fig. 5 Contents of delivery

**Note!**

Please keep the original packaging in case the applicator must be returned.

**Attention!**

The device and printing materials will be damaged by moisture and wetness.

- ▶ Only set up label printer with applicator in dry locations protected from moisture and splashes.

3.1 Standard Operation

- ▶ Check all external connections.
- ▶ Load the material. Ensure that the locking system is locked ▷ "Operator's Manual" of the printer.
- ▶ Open the shutoff valve.



Attention!

- ▶ Ensure that the pad is not covered by a label when switching on the printer-applicator system. Otherwise the vacuum sensor may be calibrated incorrectly.

- ▶ Switch on the printer.



Note!

If the pad is outside the starting position when the printer-applicator system is switched on the procedure will be interrupted with an error message visible on the display.

Pushing the pause button on the printer will negate the error moving the pad to the starting position. The Applicator is ready for work.

- ▶ Press the  at the printer.
A synchronization feed is initiated. The processed labels have to be removed manually. After a few seconds the printer carries out a short backfeed to position the front edge of the next label at the printing line.



Note!

This synchronization also has to be carried out when the print job has been interrupted with the cancel key. Synchronizing is not necessary when the print head was not lifted between print jobs. This also applies if the printer was powered down between print jobs.

- ▶ Start a print job.
- ▶ Start the labelling process via PLC interface.

Error messages during labelling process are shown in the display of the printer ▷ „4 Error Messages“

3.2 Cleaning



Attention!

Never use solvent and abrasive.

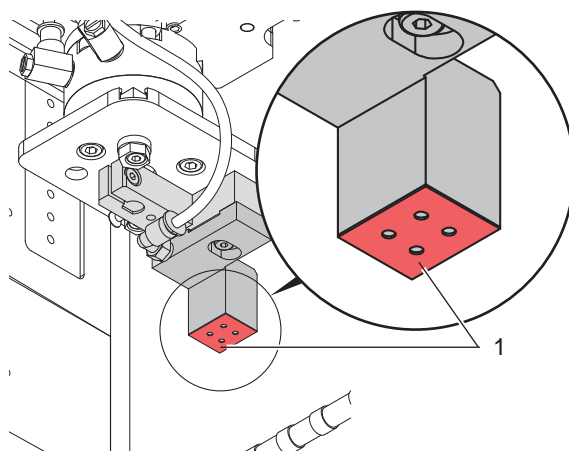

- ▶ Clean the outside surfaces with multi purpose cleaner.
- ▶ Remove dust particles and leftover label pieces with a soft brush and/or vacuum cleaner.
- ▶ The slide foil (1) requires regular cleaning as most of the dirt will accumulate here.

Fig. 6 Cleaning the pad

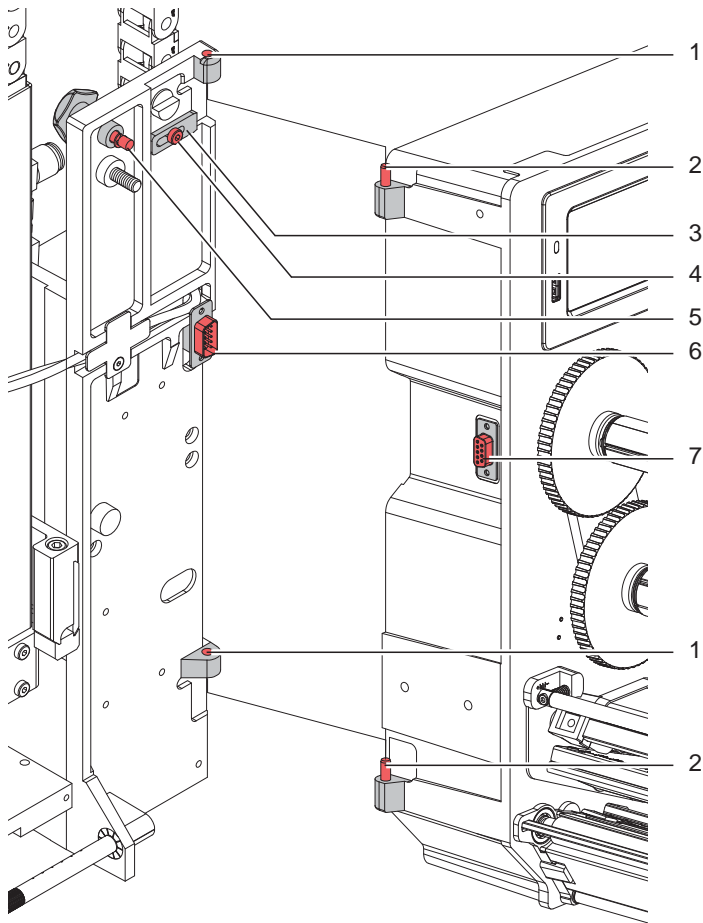

Fig. 7 Mounting the applicator to the printer



Attention!

- ▶ **Disconnect the printer from the power supply before mounting the applicator!**
- ▶ **Ensure a stable positioning of the printer!**
- ▶ **Connect the compressed air only after mounting the applicator to the printer!**

To clean the applicator and printer it is sometimes necessary to turn away or even dismount the applicator from the printer.

Take care not to adjust the setting screws, throttle valves or other alignment elements. This will enable use of the applicator directly after cleaning.

Pivot Away/Dismount the applicator

1. Loosen thumbscrew (5) and swing the applicator away.
2. Disconnect SUB-D 15 male connector (6) from the female connector (7) of the printer.
3. Loosen screw (4) and remove the locking plate (3) from the hinges.
4. Lift the applicator from the hinges.

Mount the applicator

5. Hang on the applicator with the female parts (1) of hinges on the hinges parts (2) of the printer.
6. Connect the SUB-D 15 male connector (6) to the female connector (7) of the printer.
7. To secure the applicator against slipping out of hinges, loosen screw (4), move metal part (3) under the hinge and tighten screw (4).
8. Swing the applicator to the printer and tighten the thumbscrew (5).

3.3 Movement of the Pad

The applicator 4214 has different takeover modes. The position of the pad is also adjustable.

The base position of the pad will be described in ▷ „6.1 Adjusting the Pad“. The kind of takeover mode is dependant on the label size and material. The standard takeover procedure occurs without the intermediate steps of the "take over from above" application mode.

No	Movement of the pad	Label hand-over up, apply 0° swing	Label hand-over up, apply 90° swing	Label apply 0° swing *	Label apply 90° swing *
1	Pad moves to the dispensing plate of the printer (take up of the label)	X	X		
2	Pad departs from the dispensing plate of the printer	X	X		
3	Pad pivots out via the rotation cylinder	X	X	X	X
4	Pad moves to the intermediate position below the dispensing plate of the printer and stops	X		X	
5	Pad will pivot back via the rotation cylinder	X		X	
6	Pad moves to the product un-pivoted and applies the label	X		X	
7	Pad moves to the product pivoted and applies the label		X		X

* Takeover of the label via vacuum and support air with a set distance between the pad and dispensing plate.

Table 2 Phases of pad movement

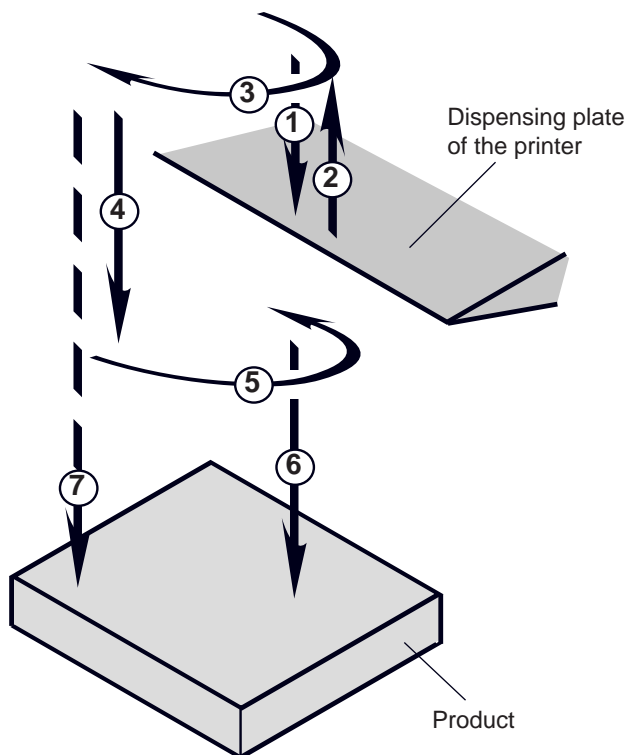

Hand-over up switch active on/off

Menu navigation:



Label swings out and applies

This function will be controlled by the I/O interface of the printer.

The signal **LBLROT (EDR - Hermes+)** on Pin 24 will be used to control this function.

▷ Operator's Manual of the printer

Fig. 8 Movement of the pad

4.1 Error Messages of the Printer

For detailed information about printer errors (e.g. 'Paper out', 'Ribbon out', etc.) ▷ Check the operator's manual of the printer.

Error treatment:

- ▶ Clearing the error results.
- ▶ Press the  respectively **feed** to synchronize the label feed, remove the left over labels manually.

To quit the error state press *Repeat* (HERMES Q) respectively the **pause** key (Hermes +).
 After error correction, the label causing the error will be reprinted.

4.2 Error Messages of the Applicator

The following table contains an overview of applicator specific error messages and their possible causes. It also suggests methods to resolve the error states:

Error Message	Possible Cause
<i>Air pressure ins.</i>	Compressed air is switched off
	Pressure to low < 4 bar
	Pressure to high > 6 bar
<i>Label not depos.</i>	Label has not been placed onto the product; after the pad has moved back the label is still sticking to the pad.
<i>Lower position</i>	Pad has not reached the starting position within 2s after the pad has left the labelling position; or pad has left the starting position without authorization.
<i>Process Error</i>	Process of labeling was interrupted via the I/O interface of the printer with the STP signal.
<i>Refl. sensor blk.</i>	There has been no change of state of the upper sensor of the cylinder from the start of the labelling process and the signal of the labelling position sensor.
<i>Upper position</i>	Pad is not in the starting position when the printer was switched on.
	Pad has not reached the labelling position within 2s after the movement of the pad was started.
	Pad has left the printing position without authorization.
<i>Vac. plate empty</i>	Label has not been picked up properly by the pad; or label fell off the pad before it could be placed onto the product.

Table 3 Error messages of the applicator

Error treatment:

- ▶ Clear the error state.
- ▶ In order to clear the error state press **continue, repeat** or **cancel**.
 - Continue* with the next label in the printing queue.
 - Repeat* repeat the print of the label causing the error.
Only applicable with error *Vac. plate empty*.
 - Cancel* the current print job.



Warning!

After the error has been resolved the pad will immediately move back to the starting position!

Danger of injury to hands and fingers by the moving pad!

- ▶ **Do not reach into the area of the moving pad and keep long hair, loose clothes, and jewelry away.**

Reprinting a label, interrupted by an error, is not possible without a new printing job.

- ▶ In the mode "apply/print" before the standard cyclic operation can commence the signal "print first label" must be sent or push  to send a printed label to the pad.

5.1 Factory default Settings



Note!

The applicators default factory settings guarantee reliable operation within the same configuration.

The factory default settings are:

- Connected to a cab HERMES Q printer, vertical
- Used Pad for factory settings: cab part No.: 5940831 25x10 for L
cab part No.: 5956410 25x10 for R
- Material used for factory default settings: cab part No.: 5556470 25x10
- Pressure value of the compressed air: 0.45 MPa (4.5 bar)
- Factory setting sensors
 - Cylinder Z ▷ „6.9 Sensors on Cylinder Z“
 - Cylinder R ▷ „6.13 Sensors on Cylinder R“
- Factory settings throttle valves
 - Cylinder Z ▷ „6.8 Lift Speed of Cylinder Z“
 - Cylinder R ▷ „6.12 Lift Speed of Cylinder R“

5.2 Tools





Screwdriver with parallel blade	2.5		<ul style="list-style-type: none"> • To adjust the throttle valves and product sensor
Hexagon key L-wrench	0.8		<ul style="list-style-type: none"> • To adjust the sensors (in contents of delivery)
	2.5		<ul style="list-style-type: none"> • For matched norm parts (in contents of delivery)
	4		<ul style="list-style-type: none"> • Pad adjustments Changing pad
Flat-round nose - straight - angled			<ul style="list-style-type: none"> • To mount/dismount tubes
Open spanner	SW 8		<ul style="list-style-type: none"> • To change the throttle valves
	SW 13		<ul style="list-style-type: none"> • Setting the spring strength of the adapter bolt
	SW20		<ul style="list-style-type: none"> • Changing the cylinder
Manometer	± 7 bar		<ul style="list-style-type: none"> • Air pressure control

Table 4 Tools

5.3 Mounting and Dismounting the Cover

To initiate the applicator or for adjustments it is necessary to dismount the cover (2). After these adjustments have been completed remount the cover.



Warning!

- ▶ Do not operate the applicator without cover (2).
- ▶ Dismount the cover only for service and/or adjustment purposes.

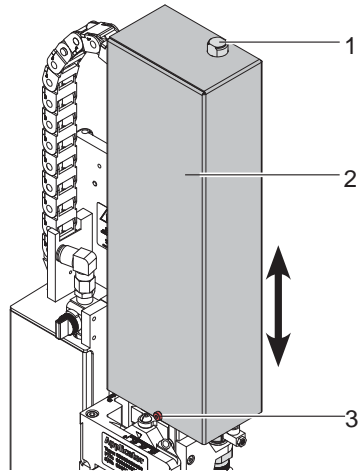

Dismount

1. Loosen screw (3).
2. Lift cover (2).

Mount

3. Move the cover (2) over the cylinder assembly.
4. Put in the cylinder (1) into the hole in the cover (2).
5. Tighten screw (3) to fix cover (2).

Fig. 9 Cover

5.4 Transportation Lock

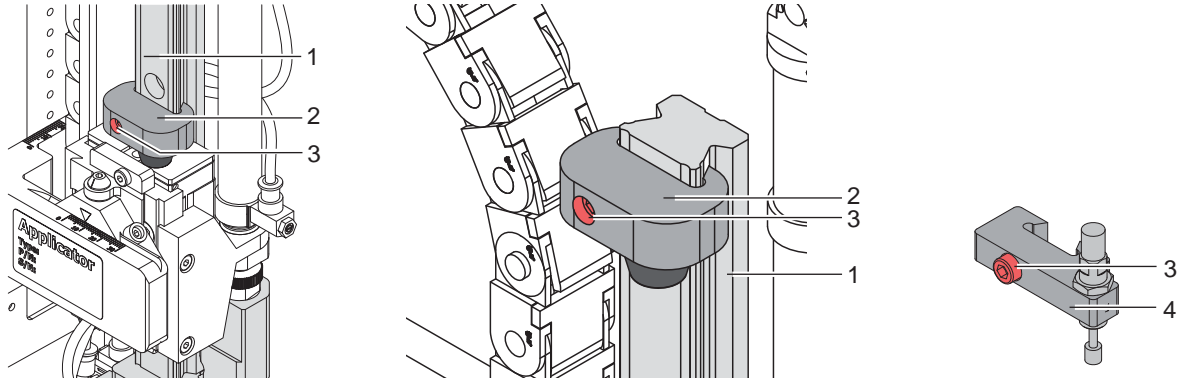

Fig. 10 Stopper as transportation lock

When the applicator is delivered, the stopper (2) is mounted on the rod (1). With this stopper (2) the labelling position for the operation mode "Blow on" can be adjusted.

In transit the stopper (2) is used as a transport lock.



Note!

To reduce the impact energy it is possible to use a stopper with cushioning (4).

Releasing the transportation lock

1. Loosen screw (3) of the stopper (2).
2. Move the stopper (2) along the rod (1) into the position as in operation mode:
 - Operation mode "Blow on": ▷ „6.7 Adjustment of the Stopper for Blow Mode“
 - Operation mode "Stamp on" : Move the stopper (2) up to the end of the rod (1).
3. Tighten screw (3) to fix the stopper (2) in position.

5.5 Mounting the Applicator to the Printer

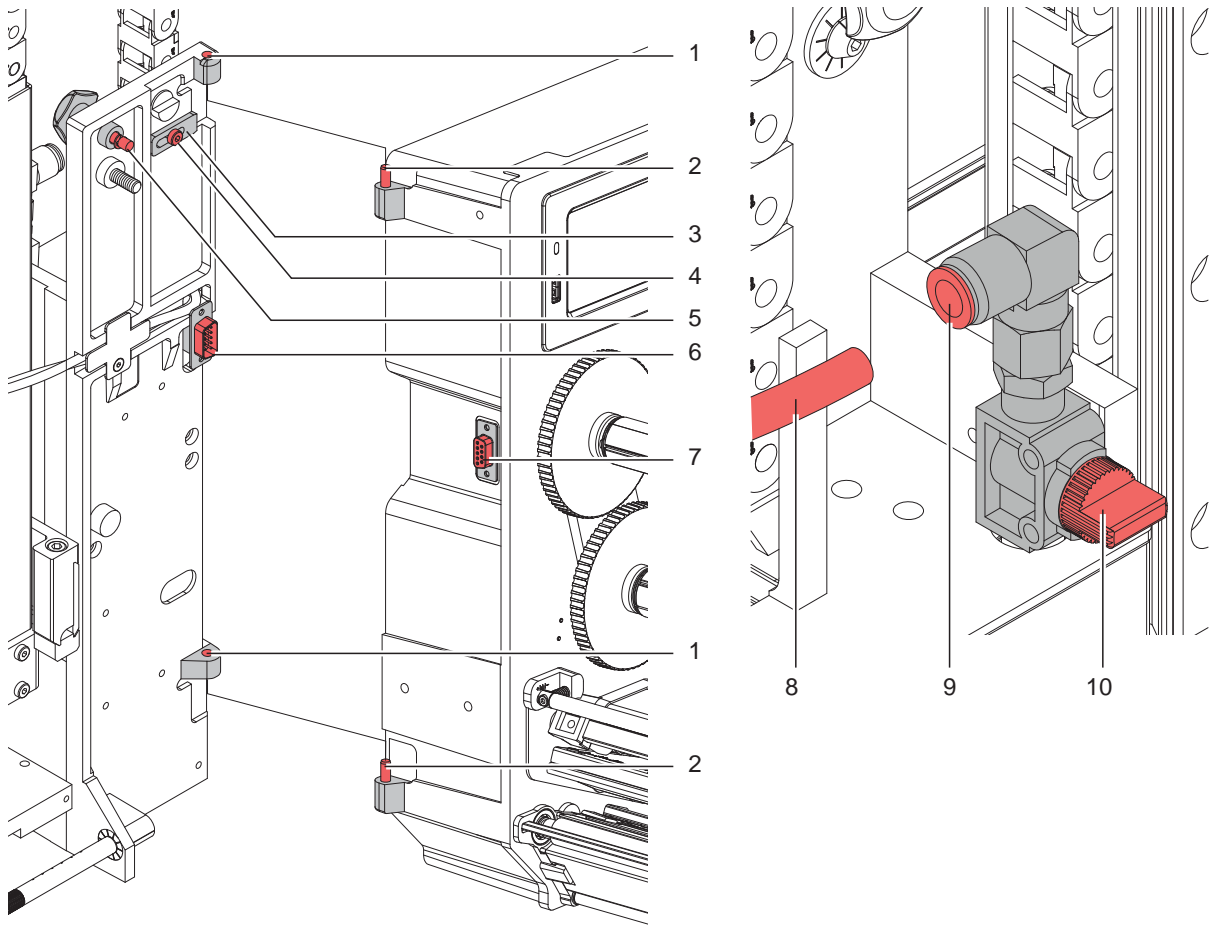

Fig. 11 Mounting applicator on printer



Attention!

Initiation, adjustments and changing of parts is only for qualified service personal only.

▷ Service Manual

Mount the applicator

1. Hang the applicator with the female part of hinges (1) at the printer mounted hinges parts (2).
2. Connect SUB-D 15 male connector (6) to the female connector (7) of the printer.
3. To prevent the applicator from slipping out of the hinges loosen screw (4) and move the locking plate (3) under the hinges and tighten screw (4).
4. Swing the applicator to the printer and tighten the thumbscrew (5).
5. Keep the external compressed air supply closed and close the shut-off valve (10) on the applicator ▷ see illustration
6. Insert external compressed air supply (8) into the plug connector (9) on the shut-off valve (10).
7. Switch on compressed air and open shut-off valve (10) by turning 90 °.

For cleaning the applicator and printer it's sometime necessary to turn away or/and dismount the applicator. Don't change the adjustments of setting screws, throttle valves or other.

Turn away/Dismount the applicator

8. To turn away the applicator loosen thumbscrew (5) and swing the applicator aside.
9. Disconnect SUB-D 15 male connector (6) to the female connector (7) of the printer.
10. Loosen screw (4) and move off the locking plate (3) from the hinges.
11. Lift the applicator upward.

5.6 Mounting the Pad

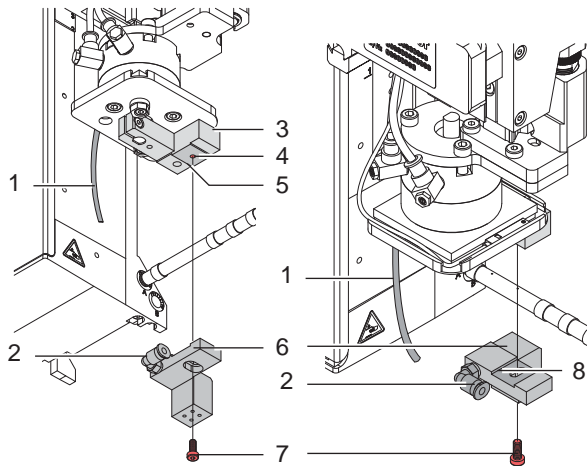

Fig. 12 Mounting the pad

1. Move the pad (6) with the cut-outs (8) along the guiding rail (5) to the bottom side of the pad holder (3).
2. Fix the pad with the screws (7) to the pad holder (3).
3. Insert the vacuum tube (1) into the appropriate connector (2) of the pad.

**Attention!**

- ▶ To avoid possible collisions of the pad with other parts of the printer-applicator system, please roughly align the pad in all directions (▶ „6 Adjustments“) before connecting the applicator to the compressed air supply!

5.7 Mounting the Blow Tube

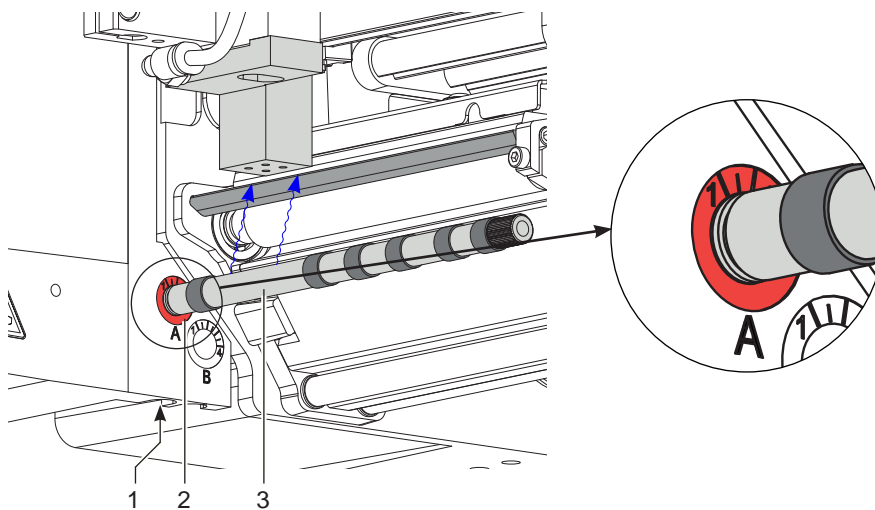

Fig. 13 Mounting the blow tube

It is possible to rotate the blow tube to optimize the direction of the support air for the take over procedure of the label from printer to applicator.

1. Loosen screw (1).
2. Put in the blow tube (3) into the hole A (2).
3. Tighten screw (1). ▶ „6.6 Adjusting the Blow Tube (Supporting Air)“

5.8 Connecting the Compressed Air



Attention!

Adjustments and functionality tests where done with a compressed air value of 4,5 bar. The applicator's operating range is between 4,0 and 6,0 bar.



Warning!

Warning!

When connecting the applicator to compressed air it is considered "IN USE!" Cylinder motion is possible!

► Do not reach into the zone of the moving pad and keep long hair, loose clothes, and jewelry away.

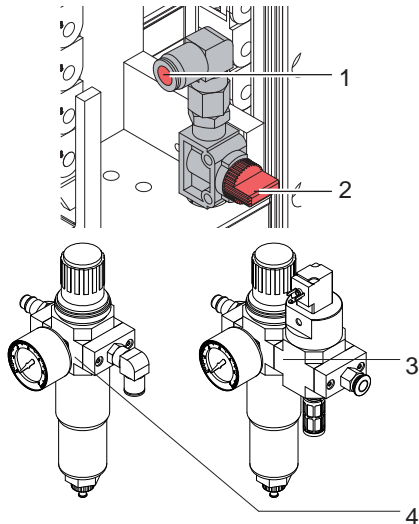

1. Check that the stop valve (2) is closed as illustrated.
 2. Attach compressed air to connector (1).
 3. Open the stop valve (2) by turning it into the direction of air flow.
 4. Switch on the printer via the power switch.
- It is possible to use an air pressure regulation unit.

cab offers two versions of air pressure regulators.

- Air pressure regulation unit with included magnetic valve (3)
Controlling via printer
▷ Interface description of the printer
- Standard version (4)

Fig. 14 Compressed air connection



Note!

If the pad is not in the starting position when the printer is switched on an error message will appear on the display.

Press the pause button on the printer to cancel the error state. The applicator will move into the start position and is ready for work.



Note!

Only mount the air pressure regulation unit as illustrated otherwise the functionality of the air-water separator cannot be guaranteed.

6.1 Adjusting the Pad

For the perfect application of labels it is necessary that the pad is placed precisely above the dispensed label.

Aligning the pad parallel to the dispensing plate

The edge of the pad should be positioned parallel to the dispensing plate of the printer in order to position the label exactly on the pad.

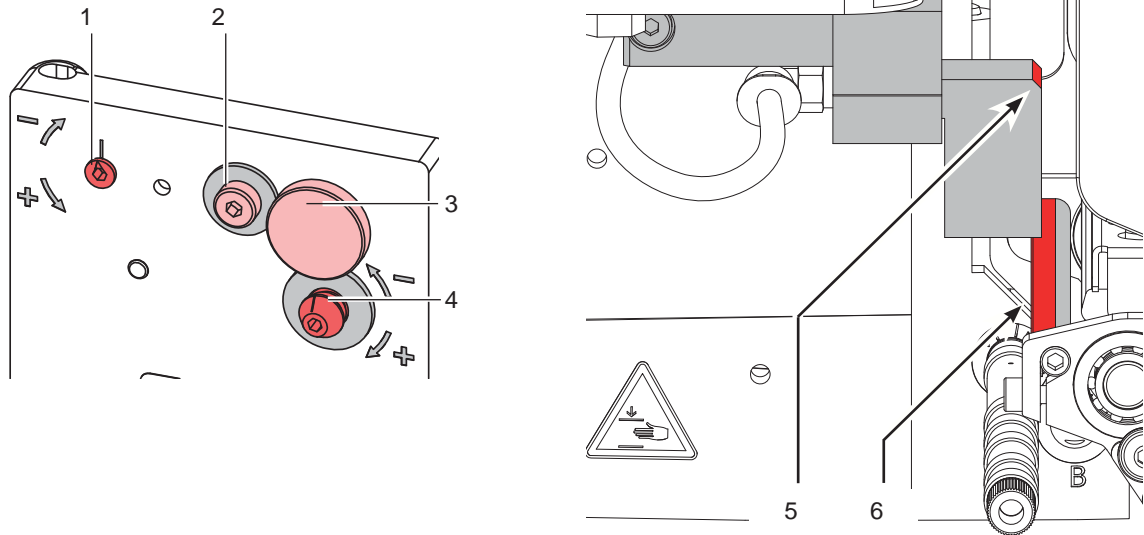
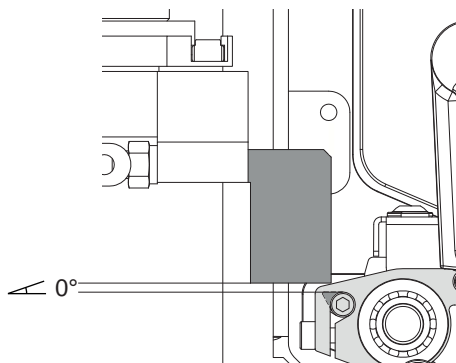

Fig. 15 Aligning the pad to the dispensing plate

1. Loosen the knurled screw (3) and the set screw (4).
2. Screw in the knurled screw (3) until the pad edges (5) are aligned parallel to the dispensing edge (6) of the printer.
3. Tighten the set screw (4) until it touches the printer.

Aligning the pad at an angle to the dispensing plate

4. If the angle between the pad surface and the dispensing edge - support surface is not 0° loosen screw (2).
5. Correct the angle of attack by turning the eccentric (1).
6. Tighten screw (2).

6.1.1 Moving the Pad in Y-Direction

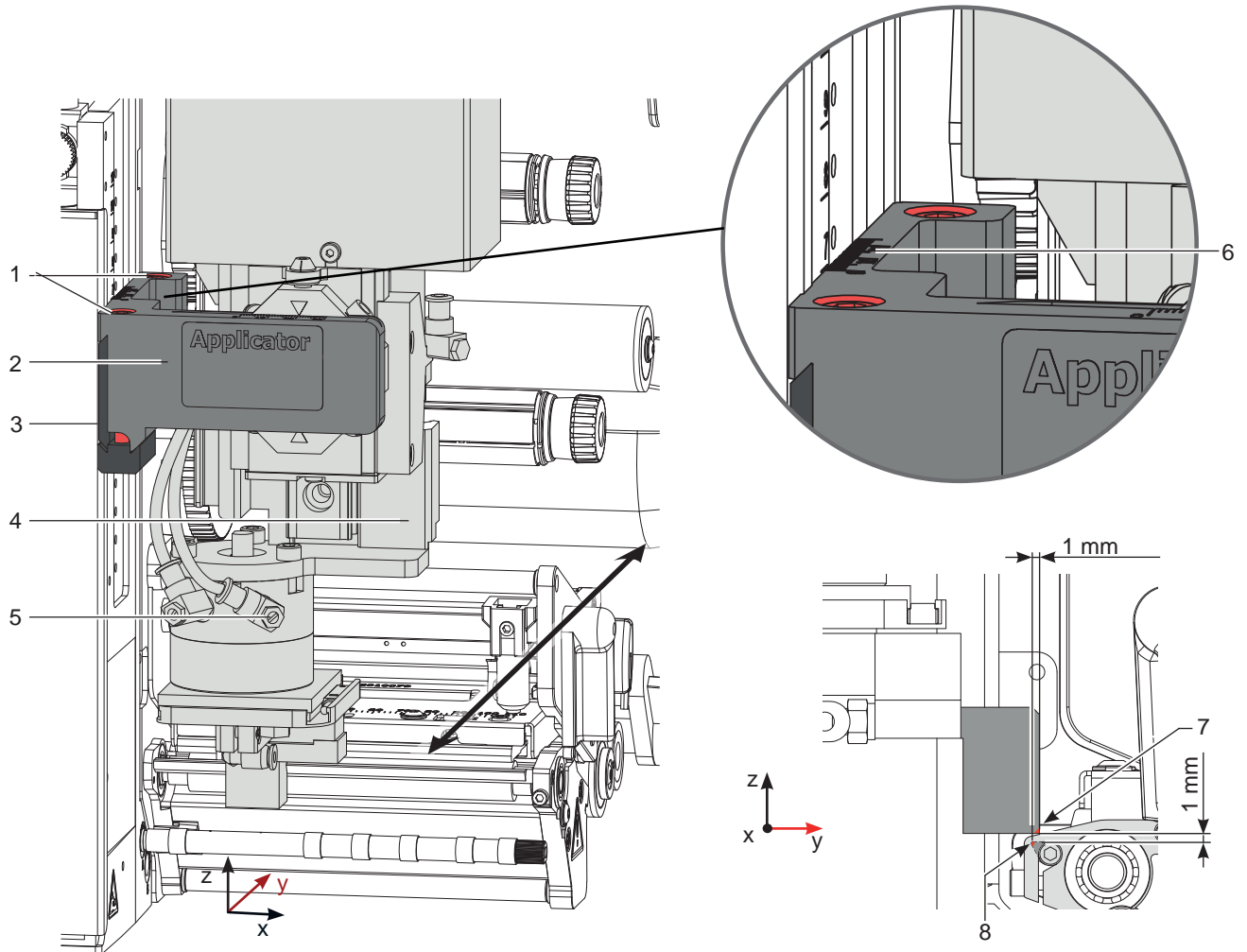

Fig. 16 Displacement in the Y direction

Displacement in the Y direction (printing direction)

1. Switch off the compressed air and pull the tube out of the throttle valve (5). Turn the pad over the dispensing plate (8) of the printer by hand.
2. Loosen screws (1) on the cross beam (2).
3. Move cylinder assembly (4) with the pad and crossbeam (2) along the guiding rail (3) that the distance from the edge of the pad (7) to the edge of the dispensing plate (8) of the printer is approximately 1 mm. Orientation: Graduation (6)
4. Tighten screws (1).
5. Put the tube back into the throttle valve (5) and switch on the compressed air.

6.1.2 Moving the Pad in Z-Direction

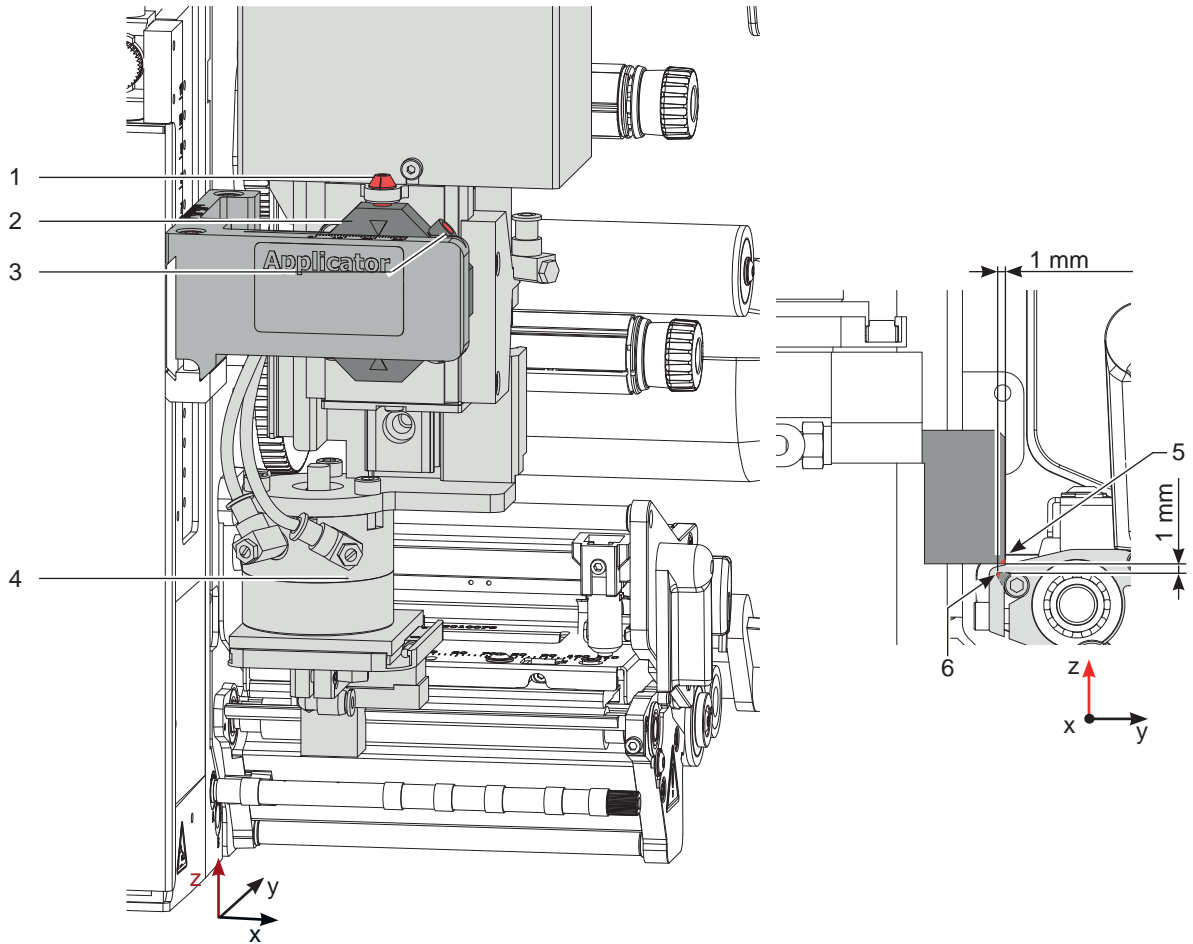

Fig. 17 Displacement in the Z direction

1. Switch off the compressed air and pull the tube out of the throttle valve (4). The cylinder extends by spring force and is in the label transfer position.
1. Loosen screw (3) on the binder (2).
2. Turn the setting screw (1) so that the bottom side of the pad is 1 mm over the top of the dispensing plate (6) of the printer.
3. Tighten screw (3).
4. Put the tube back into the throttle valve (4) and switch on the compressed air.

6.2.1 Moving the Pad in X-Direction

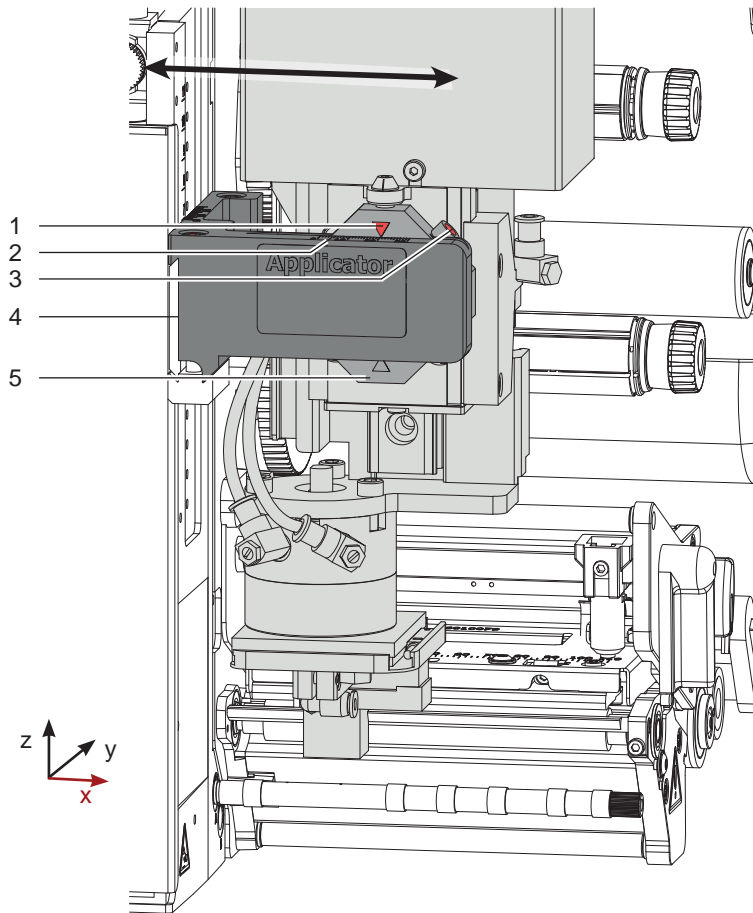

Fig. 19 Displacement in the Y direction

Displacement in the X direction (Side)

1. Loosen screw (3) on the binder (5).
2. Move cylinder assembly with the pad along the crossbeam (4) so that the dispensed label is aligned centrally to the pad. As reference use the provided graduation/ruler on the crossbeam.
Orientation: Graduation (2) and Marking (1)
3. Tighten screw (3).

6.3 Set Throttle Valves on the Cylinders

Exhaust throttle valves are installed on the cylinders of the applicator. The valves control the movement of the cylinders in the direction of the valves.

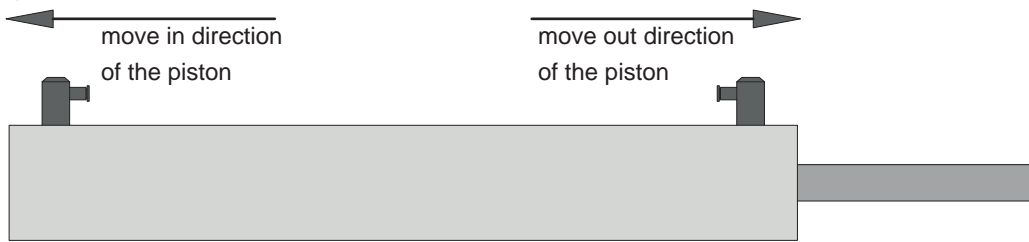

Fig. 20 Throttle valves on the cylinders



Note!

► When replacing or re-adjusting the throttle valves, always adopt the settings from the test report!

The setting values are the revolutions of the adjusting screw on the throttle valve. To do this, the throttle valve is completely closed. Turn the adjusting screw on the throttle valve clockwise until it stops.

To adjust, turn the adjusting screw on the throttle valve counterclockwise. The number of revolutions for the respective throttle valve can be found in the test protocol included in the scope of delivery of the applicator.

- Factory settings throttle valves
 - Cylinder Z ▷ „6.7 Lift Speed of Cylinder Z“
 - Cylinder Y ▷ „6.12 Lift Speed of Cylinder Y“

6.4 Set the Sensors

Sensors are used for status detection and process control on the applicator. Precise positioning is important for the applicator to function correctly. The sensors are proximity switches that are triggered by a magnet in the cylinder piston.

An LED is integrated for status detection of the sensor. This LED lights up when the sensor is triggered by the magnet in the cylinder piston.



Note!

► When replacing or re-adjusting the sensors, always adopt the settings from the test report!

Sensor and types of mounting

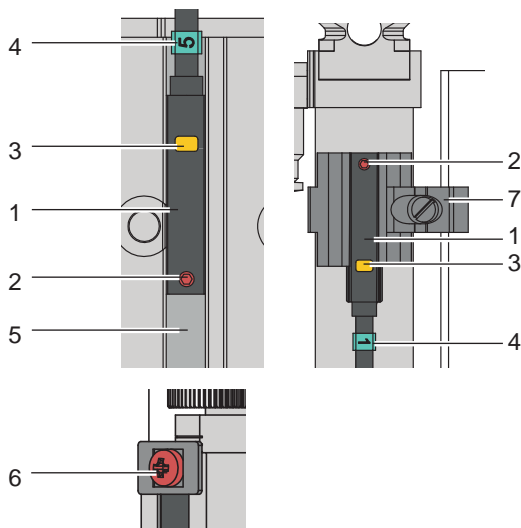

1. Sensor
2. Set screw with 0.8 mm hexagon socket to fix the sensor.
3. LED for status detection.
4. Markers on the sensor and on the connector for connection to the control circuit board
5. Guide groove on the cylinder.
6. Phillips screw with holding plate for fixing the sensor.
7. Mounting clamp for sensors.

Fig. 21 Sensor / Mounting

- Factory setting sensors
 - Cylinder Z ▷ „6.8 Sensors on Cylinder Z“
 - Cylinder Y ▷ „6.13 Sensors on Cylinder Y“

6.5 Vacuum Adjustments

The label will be held on the pad by a vacuum.

The vacuum needs to be set up in such a way that the label covers all the suction holes and is not hindered before it reaches its intended position on the pad.

The default Value of the Vacuum is -0.6 bar.

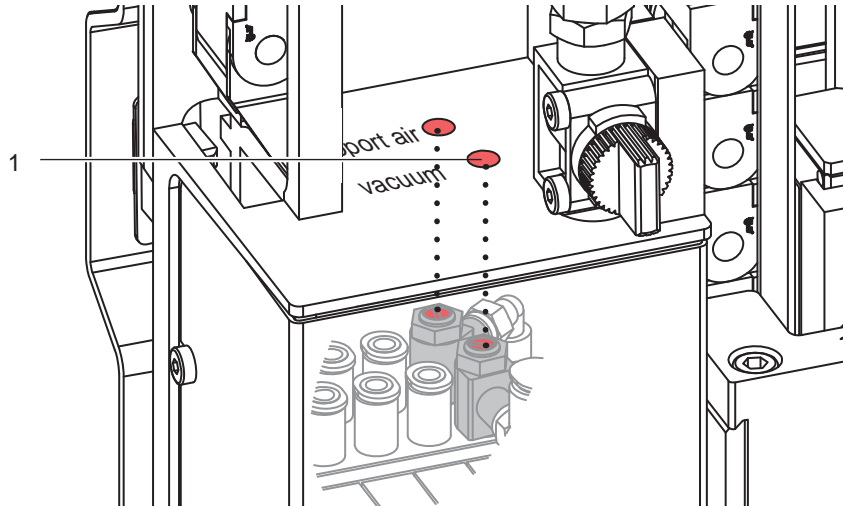

Fig. 22 Throttle valve "vacuum"

- ▶ Adjust the vacuum on the throttle valve "vacuum" (1) so that the label will be sucked up over its entire area.
- ▶ To increase the vacuum turn the setting screw on the throttle valve (1) counterclockwise.

Measuring Point Vacuum (MP V)

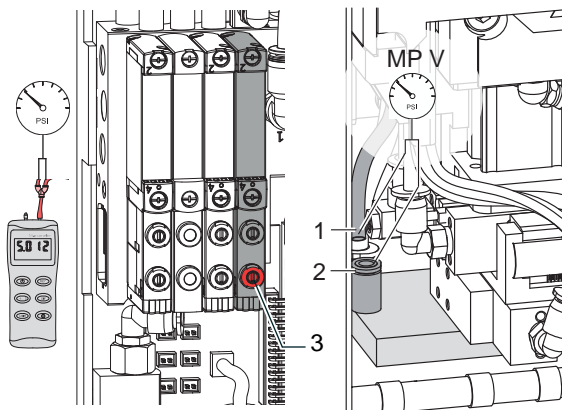

Fig. 23 Measuring points for the vacuum

Use a manometer with a measurement range of -7 to 7 bar to control the pressure.

MP V : Vacuum - Reference Value (-0.6 bar)

1. Remove cover.
2. Cover the suction plate so it is airtight.
3. Attach manometer between tube (1) of the energy chain and fitting (2) of the pad.
4. Activate the magnetic valve manually by pressing the micro switch (3) to measure the pressure.
5. Mount cover.



Attention!

After pressure measurements, reconnect all components correctly.

6.6 Adjusting the Blow Tube (Supporting Air)

The blow tube must be adjusted in such a way that the label takeover is unhindered by turbulence and the supporting air blows the label evenly against the pad.

The default factory value is 2 bar.

**Note!**

When changing the label size (2", 4" or 6") the appropriate blow tube is to be used.

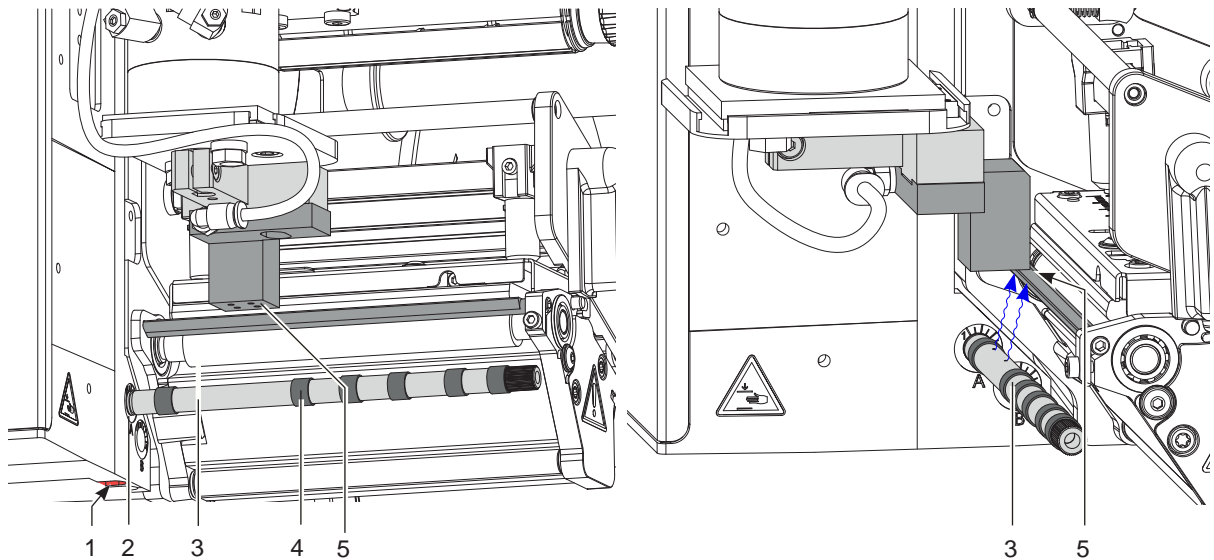

Fig. 24 Adjust the blow tube

The blow tube (4) for the supporting air can be rotated around its axis. That way the direction of the supporting air can be optimized.

1. Loosen screw (1).
2. Put the blow tube (3) into the tube adapter B (2).
Turn the blow tube (2) in the direction that the air current can support the take up of the label.
 - For small labels direct the air current more toward the dispensing edge (5) of the printer.
 - For larger labels direct the air current away from the dispense edge (6).
3. Open as many holes of the blow tube as are needed to cover the label width. Remove rings (4) if necessary.
All holes outside the label width should be covered with the shrink tube rings provided. Once the unneeded holes have been covered the shrink tube should be shrunk.
4. Tighten screw (1).

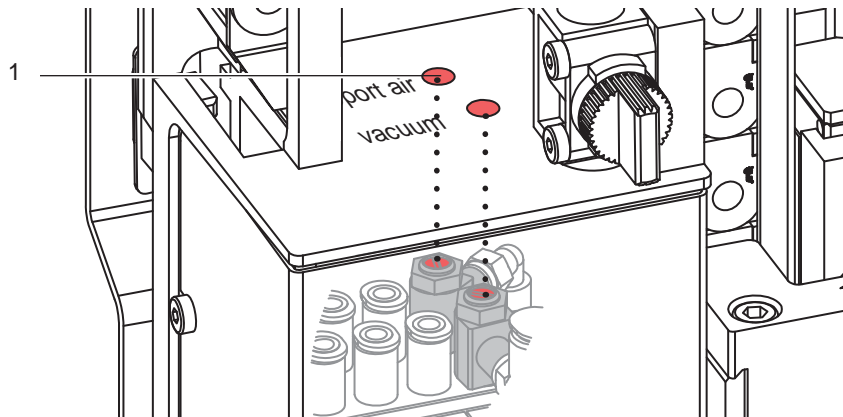
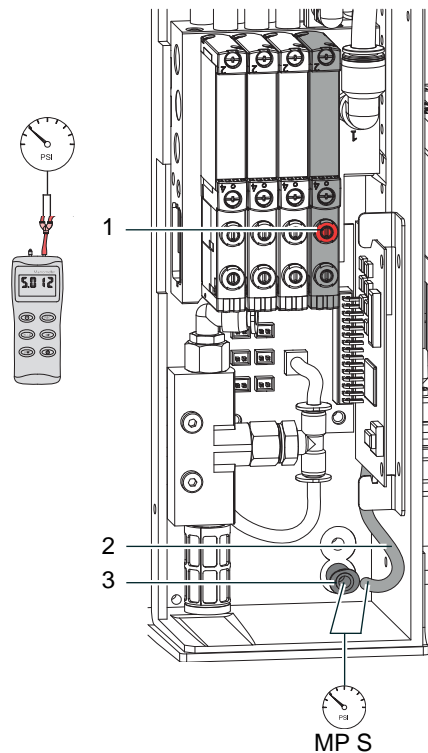

Fig. 25 Throttle valve "support air"

The strength of the supporting air can be varied via the provided throttle valve (1).

► To increase the strength of the supporting air turn the throttle valve (1) counterclockwise.

Measuring Point Support Air (MP S)



Use a manometer with a measuring range of -7 to 7 bar to measure the pressure.

MP S: Supporting Air (reference value 2 Bar)

1. Dismount cover and connect the manometer to the MP S.
2. Attach manometer between tube (2) and fitting (3).
3. Activate the valve manually by pressing the micro switch (1) to measure the pressure.
4. Mount cover.

Fig. 26 Measuring support air



Attention!

After pressure measurements, connect all components correctly.

6.7 Adjustment of the Stopper for Blow Mode



Note!
For operation mode "Blow on" only!

The operation mode "Blow on" allows labelling without contact.

The pad does not press on the product. The label will be blown from the pad onto the product over a distance of up to 10 mm.

**Attention!**

► Switch off the printer and close the shutoff valve of the compressed air via the shut-off valve!

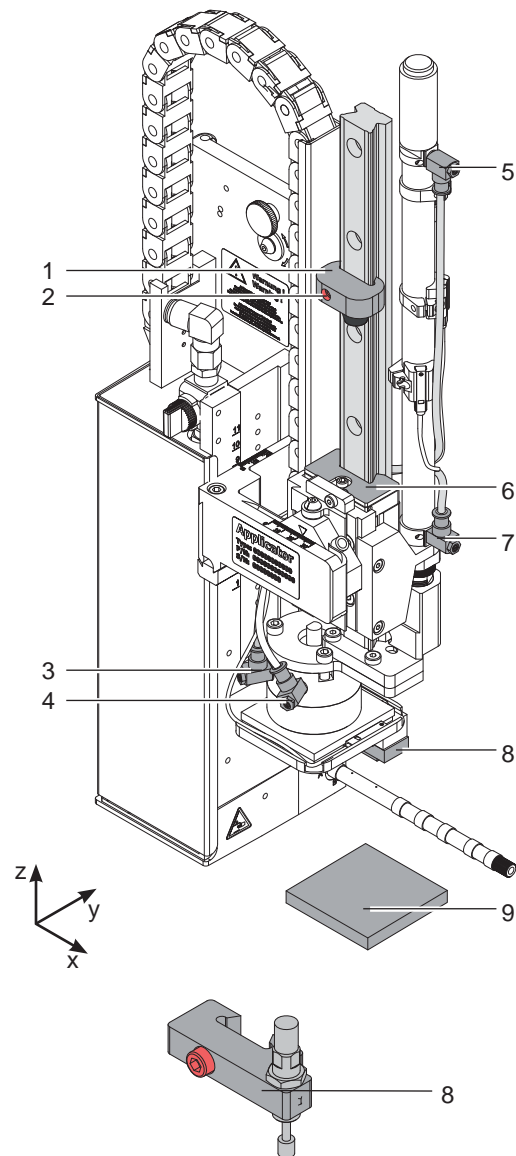

1. Place a product sample (9) on the labelling point.
2. Pull the tubes out of the push-in-fittings (5,7).
3. Loosen the screw (2) of the stopper (1).
4. Move the pad manually in the desired labelling position. The distance between the blow pad (8) in the labelling position and the product surface (9) must not exceed 10 mm.
5. Move the stopper (1) along the guide block (6) and tighten the screw (2)
6. Insert the tubes into the appropriate push-in-fittings (5,7).
7. Open the shutoff valve and switch on the printer.



Note!
To reduce the impact of the pad it is possible to use a stopper with cushioning as illustrated in option (8).

Fig. 27 Adjusting the stopper

6.8 Lift Speed of Cylinder Z

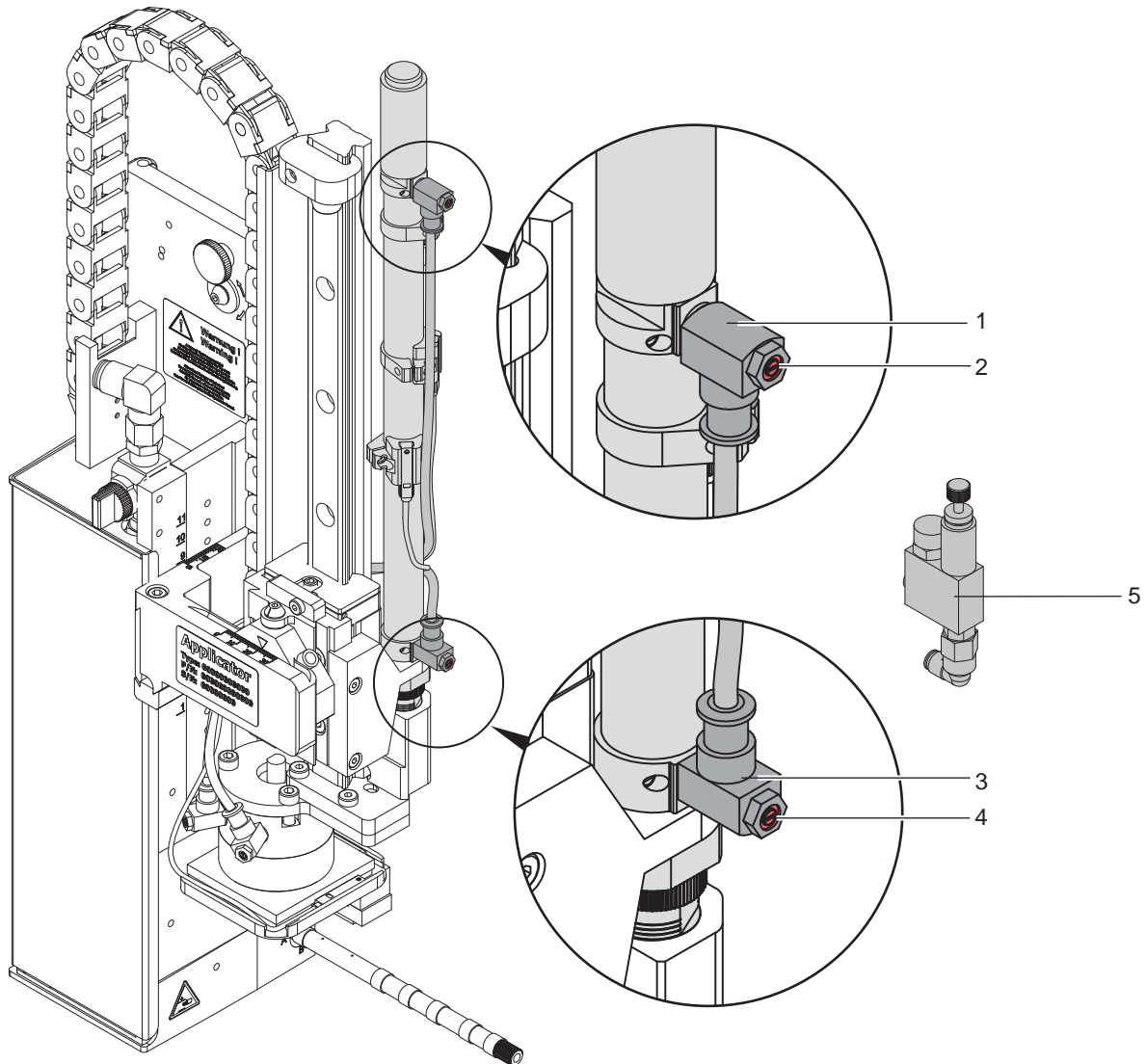

Fig. 28 Throttle valves on the cylinder Z

The speed of the pad movement can be regulated by two throttle valves (1, 3).

- ▶ Adjust the pad movement speed as necessary.
- ▶ To increase the downward speed turn screw (4) at the lower valve (3) counterclockwise.
- ▶ To increase the upward speed turn screw (2) at the upper valve (1) counterclockwise.

**Note!**

The application pressure of the pad is mainly depending on the downward speed of the pad.

- ▶ In order to reduce the application pressure turn screw (4) clockwise.

**Attention!**

The time for the downward movement of the pad may not exceed 2 seconds otherwise the error message "Lower position" will appear.

**Note!**

To reduce the air pressure in Z-direction it is possible to use an optional pressure reduction valve (5).

- ▷ „6.11 Adjusting the Options for Z-Direction Movement“

6.9 Sensors on Cylinder Z

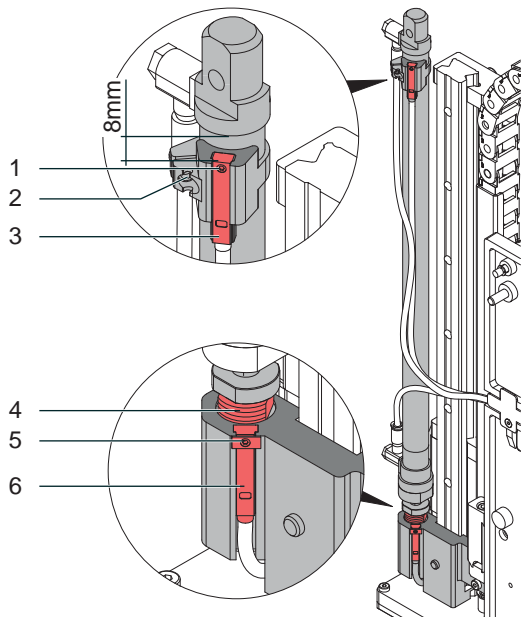

Fig. 29 Sensors on cylinder Z

Sensor 1 Start Position

1. Loosen screw (1) of the sensor "Start Position" (3) and move the sensor so that the top edge of the sensor is on the same level as the sensor holder.
2. Loosen screw (2) and move the sensor holder to a distance of 8 mm between top edge of the sensor and the lower edge of the connecting ring of the cylinder like shown in the illustration.
3. Tighten screw (2).
4. Check the sensor in the applicator operation.
 - Cylinder is moved in and the pad is in start position. - LED at the sensor glows
 - The pad is not in the start position. - LED at the sensor does not glow

Sensor 2 Labelling

The position of the labelling sensor (6) is dependant on the pad assembly's weight and the mounting position. The spring tension on the adapter bolt is dependant on these parameters and must be adjusted so that the sensor cannot trigger unintentionally. The triggering magnet is integrated in the adapter bolt and changes position with the tension spring.

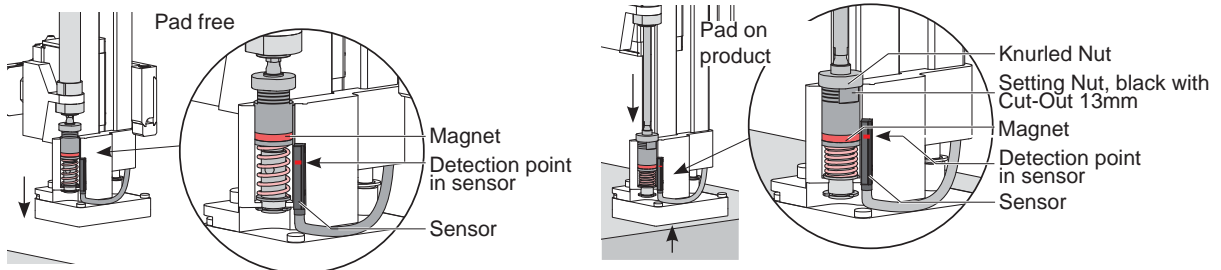

Fig. 30 Labelling sensor principle

1. Getting the printer and applicator into the final orientation.
2. Adjust the spring tension on the adapter bolt (4) via the black setting nut so that:
 - The adapter bolt is not pushed into the stamp assembly group during motion.
 - The sensor triggers when the pad has reached the labeling position.
3. Turn the setting nut with an open spanner 13 mm and fix the knurled nut by holding it.
 - Turning the setting nut clockwise will increase the spring tension.
 - Turning the setting nut counterclockwise will decrease the spring tension.
4. Loosen screw (5) and move the sensor (6) so that the LED lights up when the adapter bold is pushed into the pad assembly.
5. Tighten screw (5).

6.10 End Position Cushioning



Note!

The end position cushioning of the cylinder is set up to client specifications and does usually not need to be adjusted.

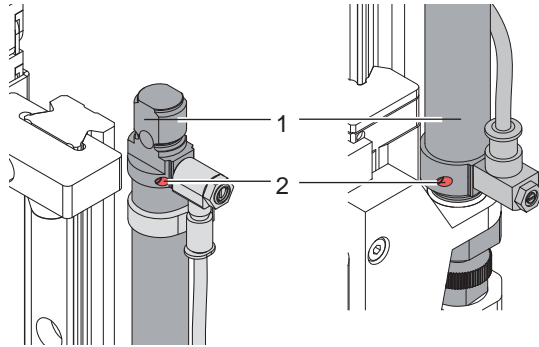

Fig. 31 End position cushioning

The end position cushioning of the main cylinder reduces the impact energy when the applicator is operating at high speeds and/or masses.

Adjust the end position cushioning so that the piston arrives the end position definitively but does not strike it too hard.

A higher level of end position cushioning will reduce the lift speed.

- ▶ To increase the value of the end position cushioning turn the setting screw (2) clockwise on cylinder (1).
- ▶ To reduce the value of the end position cushioning turn the setting screw (2) counterclockwise on cylinder (1).

6.11 Adjusting the Options for Z-Direction Movement

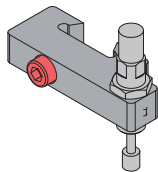

Fig. 32 Stopper with cushioning (Guide Rail)

The stopper with cushioning (guide rail) reduces the speed of the cylinder Z shortly before impact when the applicator is operated at higher speeds and/or with larger pads.

Adjustments like chapter ▶ „6.7 Adjustment of the Stopper for Blow Mode“

Adjust the stopper with maximum compressed spring.

- ▶ „5.4 Transportation Lock“

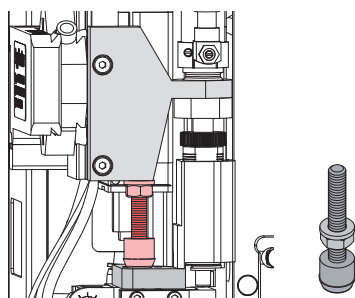

Fig. 33 Stopper (pad assembly)

The stopper avoids the triggering of the labelling sensor by the weight of the pad assembly during the inward motion of an installation turned 90° or 180°.

The setting occurs during the take-up of the label from the printer.

1. Loosen the counter nut of the stopper.
2. Turn the stopper until it touches the pad retainer lightly. Do not change the take over position of the pad by via stopper.
3. Tighten the counter nut to fix the stopper.

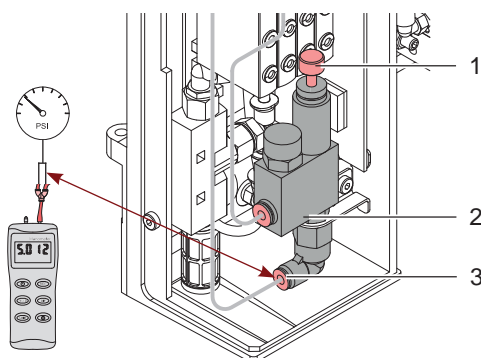

Fig. 34 Pressure reduction valve cylinder Z

The pressure reduction valve (2) can be used when labelling pressure-sensitive products or considering general safety aspects to reduce the pressure of the cylinder in Z-direction. The standard value is 2.5 bar.

- ▶ Connect the manometer between tube and exit (3) and adjust the pressure to 2.5 bar with the knurled screw (1).

It is possible to order an upgraded set with a pressure reduction valve.

Instructions are provided with the upgraded set.

6.12 Lift Speed of Cylinder R

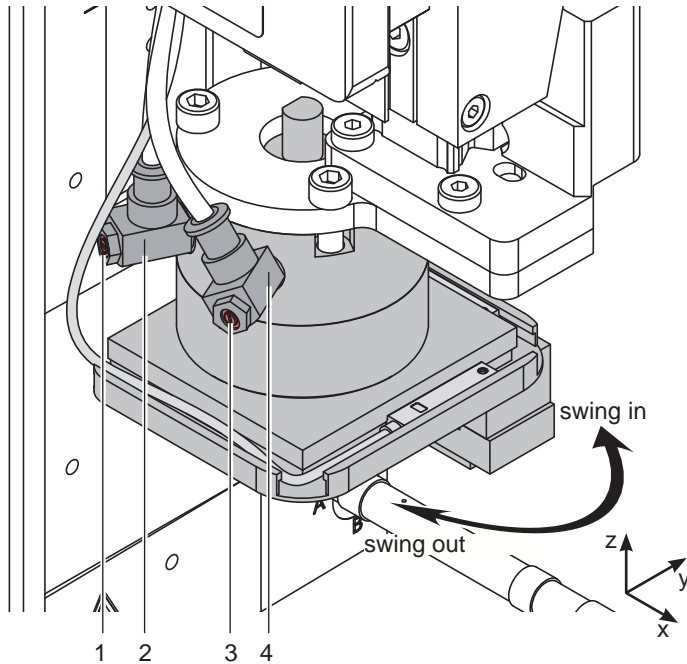

Fig. 35 One-way flow control valve of cylinder R

- ▶ Adjust speed as necessary.
- ▶ To increase the outward movement speed of cylinder R in the direction of the labeling position turn the screw (1) of valve (2) counterclockwise.
- ▶ To increase the inward movement speed of cylinder R in the direction of the labeling position turn screw (3) of valve (4) counterclockwise.

6.13 Sensors on Cylinder R

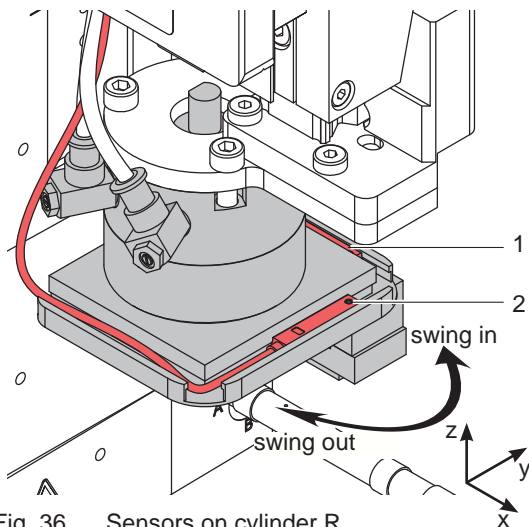

Fig. 36 Sensors on cylinder R

The sensors of cylinder R show the position of the cylinder in the state of label take-up and labeling position.

- Place the sensor start position (1) so that it is triggered if the cylinder is completely swiveled in and releases as soon as the cylinder moves from the start position.
- Place the sensor end position (2) so that it is triggered if the cylinder is completely swiveled out and releases as soon as the cylinder leaves the end position.

6.14 Settings of the Rotation Angle of the Cylinder R

To change the rotation angle from 90° to 180° and vice versa it is necessary to change the position of the sensor "End Position" and the stopper of cylinder R.

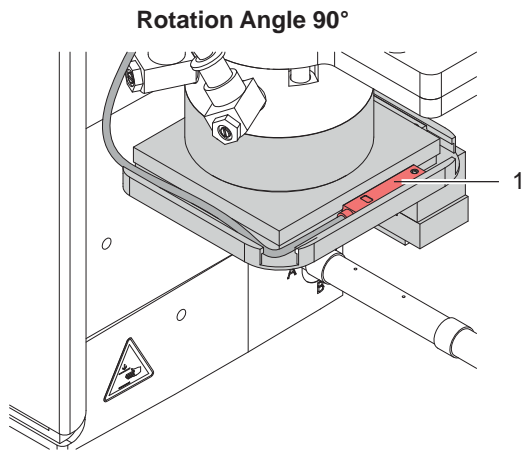

Sensor (1) must be at an offset of 90° in the direction of rotation to the start sensor.

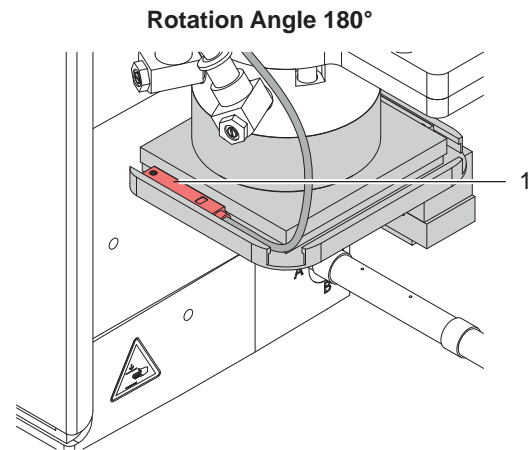

Sensor (1) must be at an offset of 180° to the start sensor.

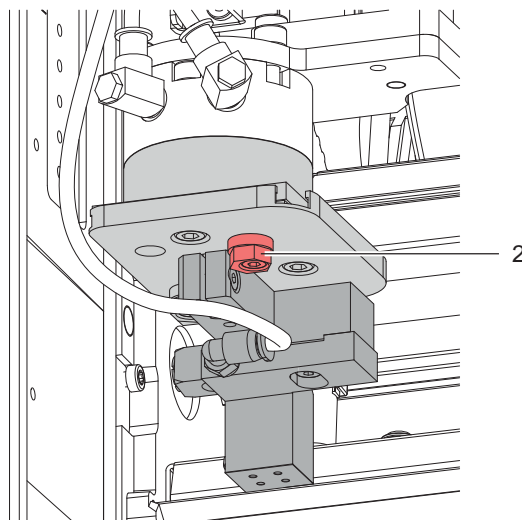

Mount the stopper (2) underneath the plate on the cylinder R the right side (view direction toward the printer)

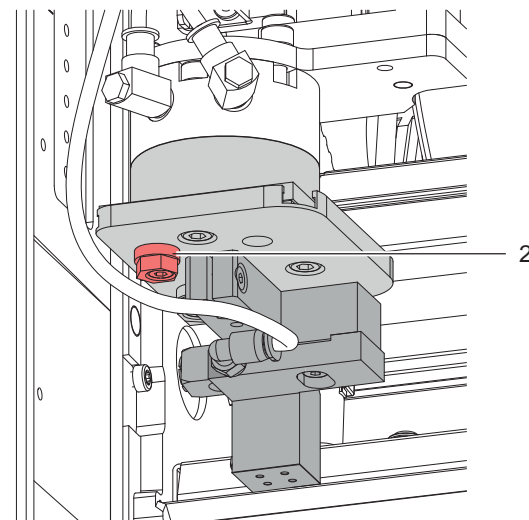

Mount the stopper (2) underneath the plate on the cylinder R the left side (view direction toward the printer)

The pictures shown an applicator 4214 L. The components for the applicator 4214 R are the mirror opposite.

Fig. 37 Changing the rotation angle



Note!

Stopper (2) is designed as an eccentric. It is possible to fine tune the end position by turning the stopper.

6.15 Labeling from Below - Changing the Spring of the Impact Sensor

For fault free labeling in a side- or upward-motion it is necessary to change the spring of the impact sensor. The stronger spring prevents the unwanted triggering of the impact sensor due to the inertia of the cylinder and stamp assembly group.

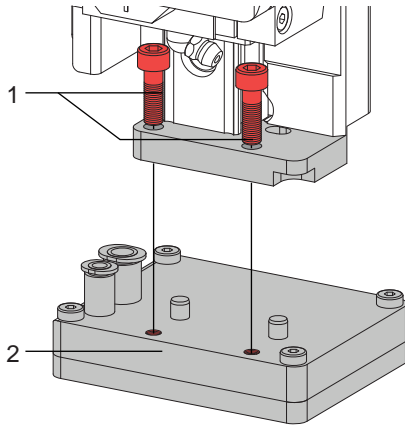

- ▶ Loosen screw (1) and dismount the stamp (2) to get to the locking washer (6).

Fig. 38 Demounting the stamp

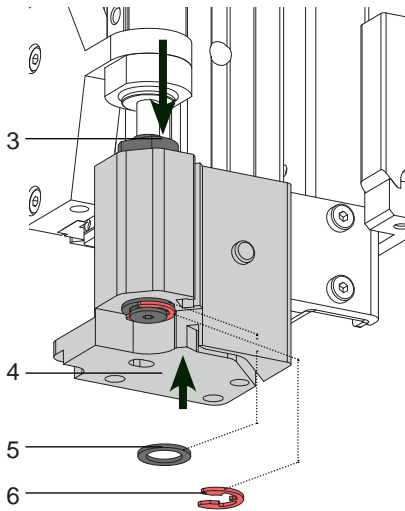

- ▶ Push the adapter bolt (3) into the stamp uptake (4) to ensure that the bottom of the bolt is pushed out. Demount locking plate (6).
- ▶ Remove washer (5).

Fig. 39 Loosening the adapter bolt

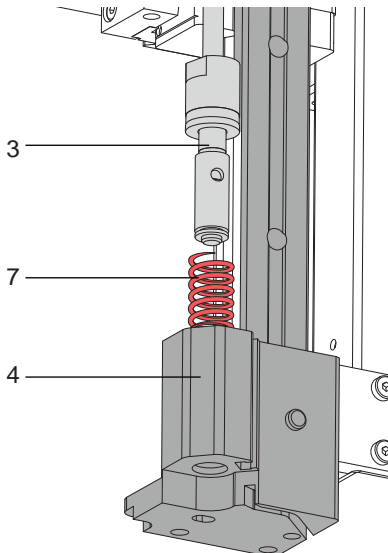

- ▶ Hold onto the adapter bolt (3) and pull off the stamp uptake (4).
- ▶ Pull out the pressure spring (6) and replace it with the alternative.
- ▶ Push together the stamp uptake (4) and the adapter bolt (3).
- ▶ Replace the washer (5).
- ▶ Place the locking washer (6) back into it's position.

Fig. 40 Changing the spring

The applicator can be operated in different ways. While the original process stays the same, the operation mode can be chosen from the printer setup.

The most important setting is the selection between the operation modes "Stamp on" and "Blow on".

Additionally the applicator has different application modes concerning the order of printing and applying within one labelling cycle.

	Stamp on	Blow on
Print/Apply	x	x
Apply/Print Waiting position top	x	x
Apply/Print Waiting position bottom	-	x

Table 5 Operation and application modes

Additionally all operating modes can be adjusted by setting different time delays.



Note!

For more information about the printer configuration and the function of the keys in the navigator pad
 ▷ Configuration manual of the printer or ▷ Operator's manual of the printer.

7.1 Method for Changing the Printer Setup

1. Press **menu** button.
2. Menu



Setup>



Labelling >

3. Select and adjust the needed parameters.
4. Return to the "Ready" mode.

7.2 Configuration Parameters of the Applicator

► Start menu.

► Select  Setup >  Labelling.













Parameter	Meaning	Default
 <i>Transfer mode</i>	Setting the operation mode <i>Stamp on, Roll on, Blow on</i>	<i>Stamp on</i>
 <i>Cycle sequence</i>	Setting the application mode <i>Print-Apply / Apply-Print</i> <i>Print-Apply:</i> An external start signal releases the print of a label and following the application of the label. After a cycle is complete, the pad without label waits in the start position. <i>Apply-Print:</i> An extra signal starts the print of the first label and the transfer of the label to the pad. The external start signal releases the application of the label and following the print and transfer of the next label. After a cycle is complete, the pad with a label is in the waiting position.	<i>Print-Apply</i>
 <i>Waiting position</i>	* Only at <i>Transfer mode = Blow on</i> and <i>Cycle sequence = Apply-Print</i> <i>up:</i> Pad waits in the start position for the start signal <i>down:</i> Pad waits in the labelling position for the start signal	<i>up</i>
 <i>Blow time</i>	* Only at <i>Transfer mode = Roll on</i> Switch-on time (max. 2,5 s) of the blowing air for the label transfer	<i>1000 ms</i>
 <i>Support delay on</i>	Setting the switch-on delay (max. 2,5 s) for the supporting air between print start and switching on the supporting air. The delay prevents swirling at the front of the label and, consequently, avoids faults when the label is being picked up from the printer.	<i>0 ms</i>
 <i>Support delay off</i>	Setting the switch-off delay (max. 2,5 s) for the supporting air between the end of label forwarding and switching on the supporting air. The delay can be useful to separate the rear edge of the label from the carrier to avoid errors and to improve the accuracy of label positioning	<i>0 ms</i>
 <i>Start delay</i>	Delay (max. 2,5 s) between start signal and the start of an labelling cycle. Allows e.g. the use of product sensors at conveyors.	<i>0 ms</i>
 <i>Lock time</i>	All start signals coming in following the first start signal are ignored when they arrive within the lock time (max. 2,5 s).	<i>0 ms</i>
 <i>Vacuum delay</i>	<i>On</i> - The vacuum will be switched on after the label feed is completed. <i>Off</i> - The vacuum will be switched on when the label feed starts.	<i>Off</i>
 <i>Vacuum control</i>	Setting the label transfer check from printer to pad and from pad to product by the vacuum sensor	<i>On</i>
 <i>Label hand-over</i>	<i>Passive</i> - The pad waits in front of the dispense edge for the label. <i>Active</i> - The pad moves to the dispense edge and takes the label.	<i>Passive</i>
 <i>Cleaning blow</i>	Activation of a short blow impulse after the application of the label to clean the suction channels.	<i>Off</i>
 <i>Peel-off position</i>	Shift the position of the dispensed label relative to the dispensing edge. The setting can also be adjusted by the software. The settings of configuration and software are added together.	<i>0.0 mm</i>

Table 6 Parameters of the Setup > Labelling menu

7.3 Setting the Peel Position

To optimize the transfer of the labels from the printer to the pad there are two different parameters available for adjusting the peel position.







Attention!

- ▶ First adjust the parameter "Peel Position" in the printer configuration.
- ▶ Then adjust the additional peel-off offset in the software.

It is very important to follow that procedure for a certain start after label loading and for the re-start after error treatment.

Parameter "Peel Position" in the printer configuration

- ▶ Check the basic settings in the printer setup. Perform labelling cycles by alternately pressing the  button and Enter button  . ▷ „8.1 Test Mode without a Print Job“
- ▶ In the submenu  Labelling >  Peel-off position adjust the "Peel-off position" in such a way, that the blank labels are peeled-off completely from the liner
▷ „7.2 Configuration Parameters of the Applicator“

Peel-off offset in the software

- ▶ Check the setting in the software. Perform labelling cycles by repeatedly pressing the Enter button  .
▷ „8.2 Test Mode with a Print Job“.
- ▶ Adjust the peel-off offset in such a way, that the printed labels are peeled-off completely from the liner
▷ Programming manual or software documentation.

7.4 Activation of Peel-off Mode



Note!

- ▶ For labelling operation activate the peel-off mode in the software.
- ▶ For direct programming use the P command ▷ Programming manual.

8.1 Test Mode without a Print Job

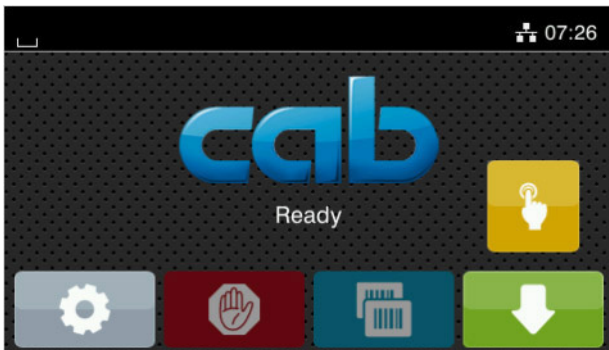





Fig. 41 Display

By alternating between buttons  and  on the display it is possible to simulate the labeling process without an active printing job.

- ▶ Push button . This causes the feed of an empty label. Simultaneously the vacuum of the pad as well as the supporting air are activated. As soon as the label has securely arrived at the pad the supporting air is switched off.
- ▶ Push button . When pushing this button the cylinder Z is extended into the labeling position. Reaching the labeling position is signaled by the triggering of the impact sensor. With that signal the vacuum is stopped and the label is applied to the product. With the application of the label the cylinder is contracted back into the starting position.

**Note!**



- ▶ Use the printer configuration to find the best peel-off offset for the initiation.

8.2 Test Mode with a Print Job

This method allows testing of the labeling process with actual printing data by using the  button.

- ▶ Send a print job.

The test mode is executed in two half cycles:

- ▶ Push the  button.
Half cycle 1
A label is printed. The vacuum of the pad as well as the supporting air (blow tube) are switched on. When the label has been picked up by the pad, the supporting air is switched off.
- ▶ Push the  button.
Half cycle 2
The pad is moved to the labelling position. The triggered impact sensor signals when the labelling position is reached. The vacuum is switched off as soon as the label is placed onto the product. Then, the pad is moved back into the starting position.

If the label is removed by hand after **half cycle 1** has been completed and the  button is pressed, **half cycle 1** will be repeated with the next label in the printing line.

**Note!**

- ▶ Use the software to find the best peel-off offset for the initiation.

9.1 Block Diagram

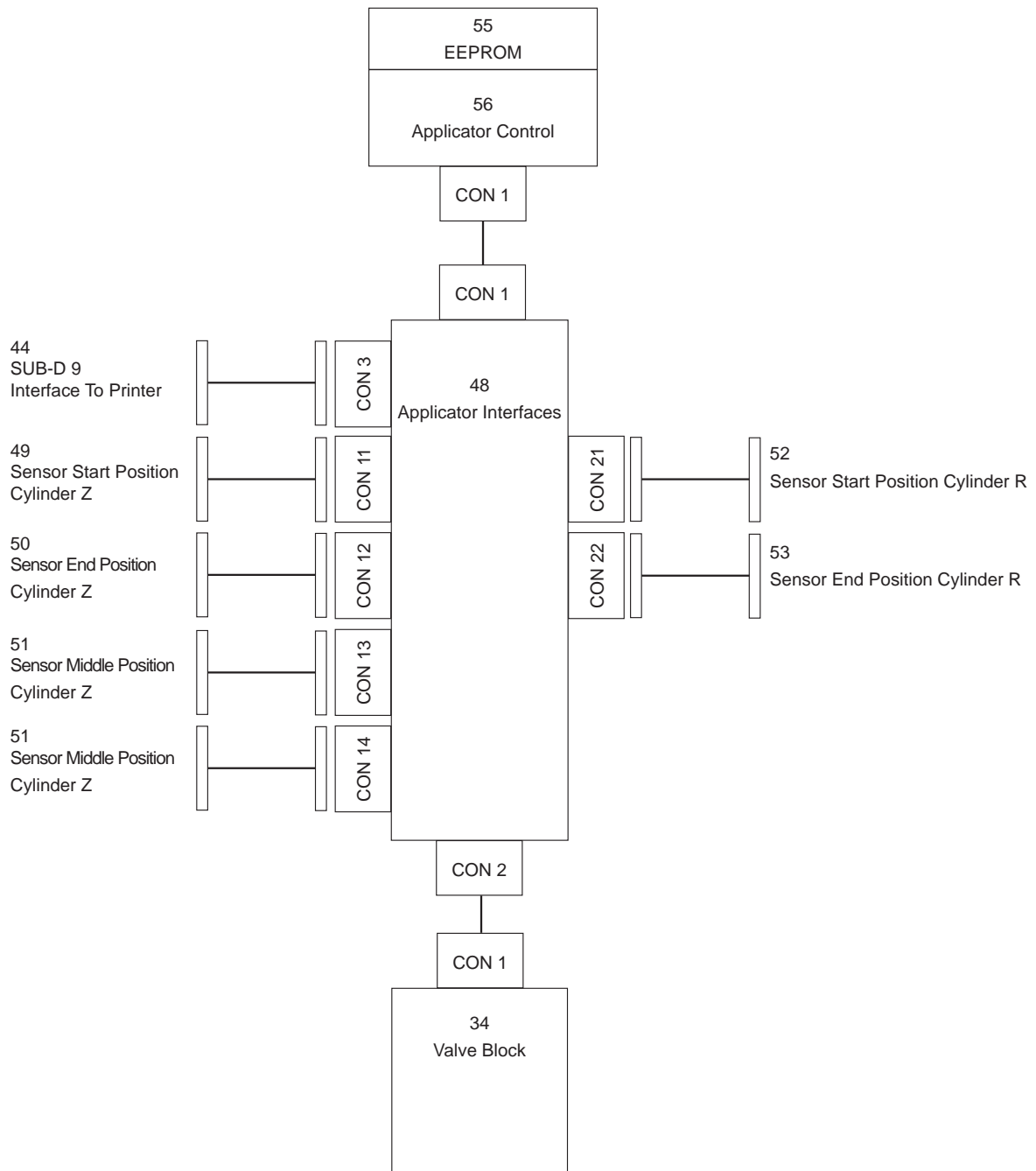

Fig. 42 Block diagram

9.2 Pneumatic Drawing Type 4214

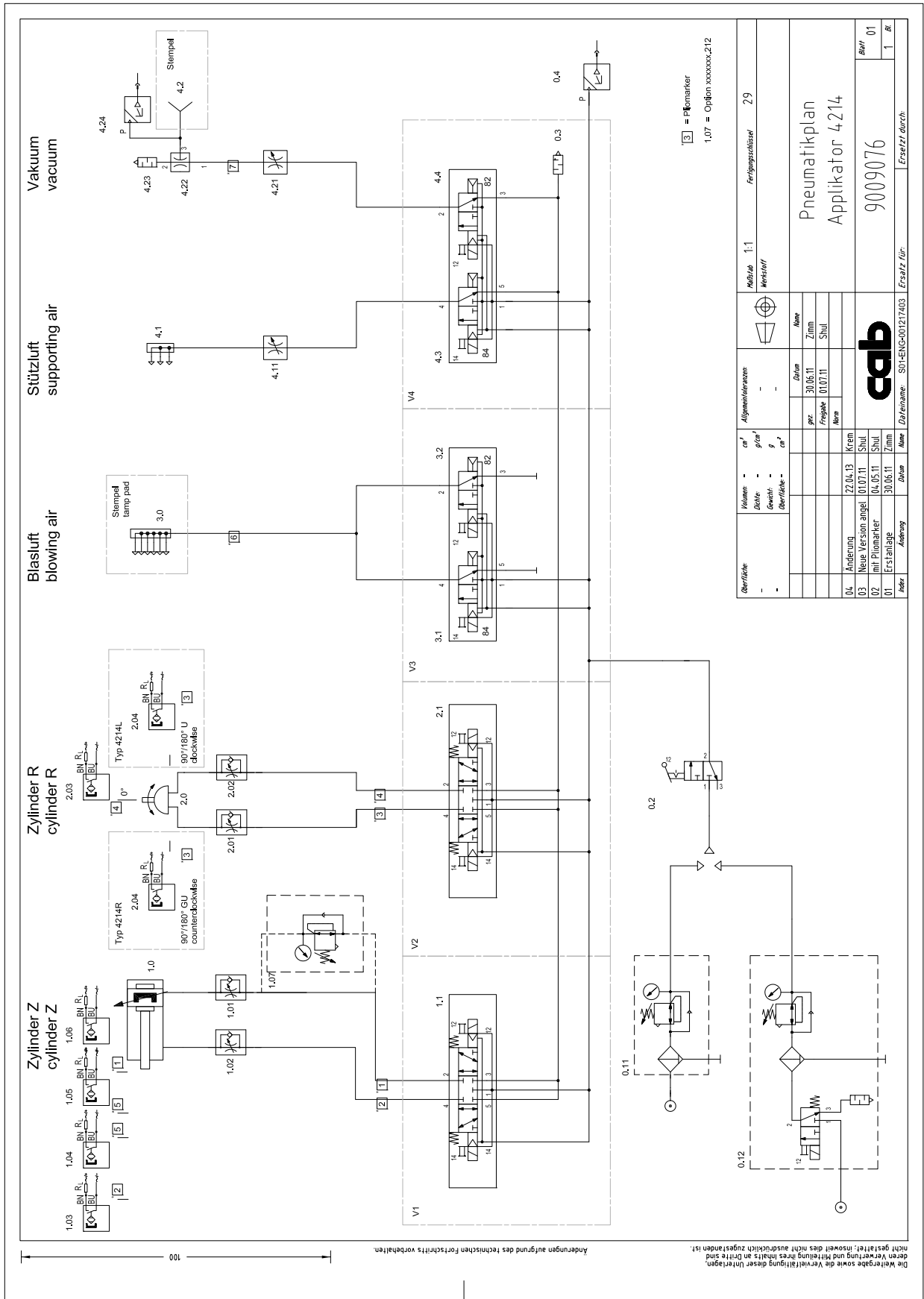
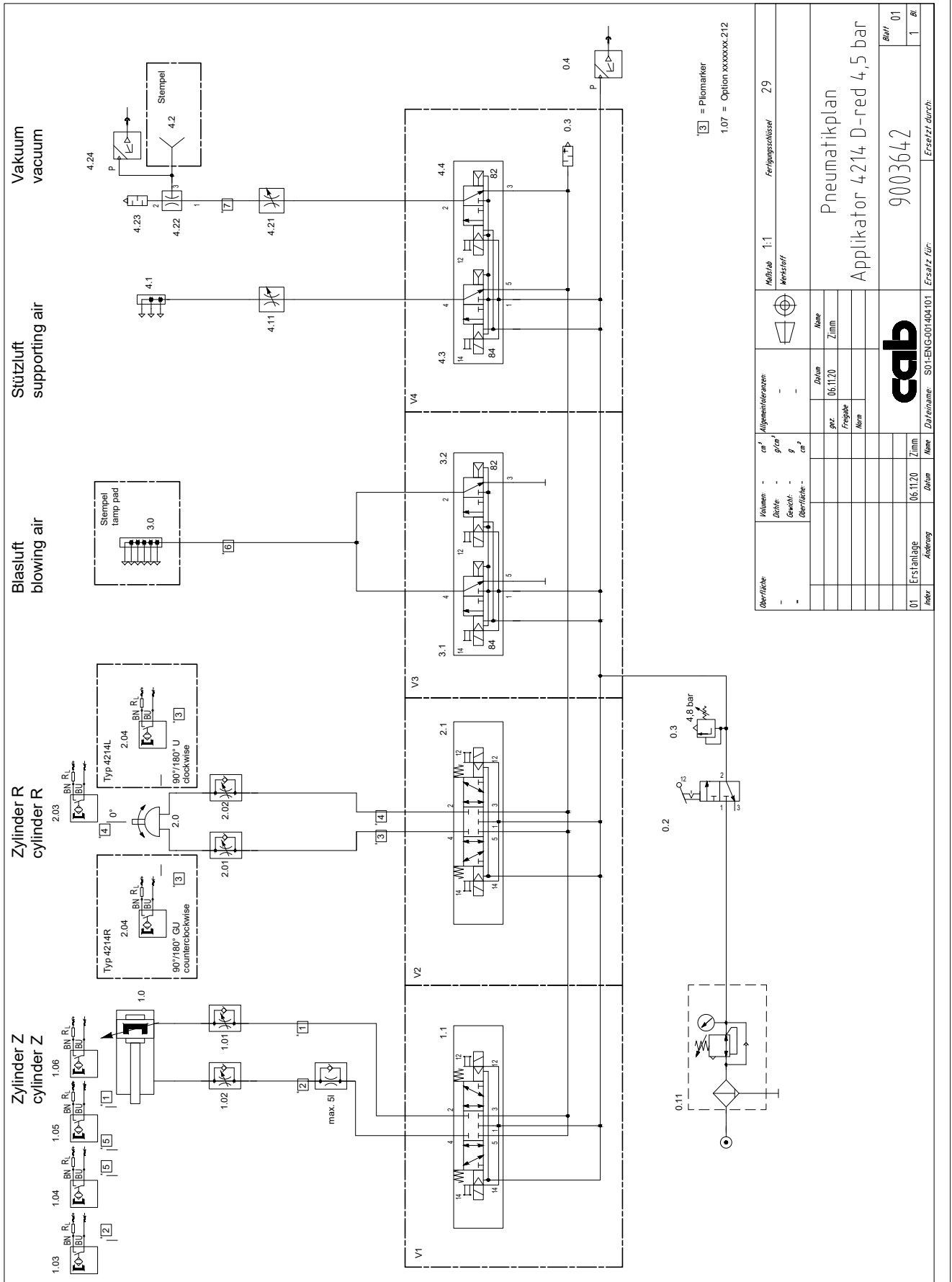

Fig. 43 Pneumatics type 4214

9.3 Pneumatic Drawing Type 4214 pressure reduced 4.5 bar



Oberfläche:		Volumen:	ca ³	Allgemeinliteratur:	Meßstab:	29	
-	-	Dichte:	g/cm ³	-	1:1	Fertigungsmaßstab	
-	-	Gewicht:	g	-	Werkstoff:	-	
-	-	Oberfläche:	cm ²	-			
		per:	06.11.20	Datum:		Pneumatikplan	
		Freigabe:		Norm:		Applikator 4214 D-red 4,5 bar	
01	Erstanlage	06.11.20	Ziml	None		9003642	
	Änderung						Blatt 01
Dateiname: S01-ENG-001-404101						Ersatz für:	

Fig. 44 Pneumatics type 4214 pressure reduced 4.5 bar

Die Weitergabe sowie die Vervielfältigung dieser Unterlagen, deren Verfertigung und Mitteilung ihres Inhalts an Dritte sind nicht gestattet; insoweit dies nicht ausdrücklich zugestanden ist. Änderungen aufgrund des technischen Fortschritts vorbehalten.

9.4 Labeling Position Type 4214 L

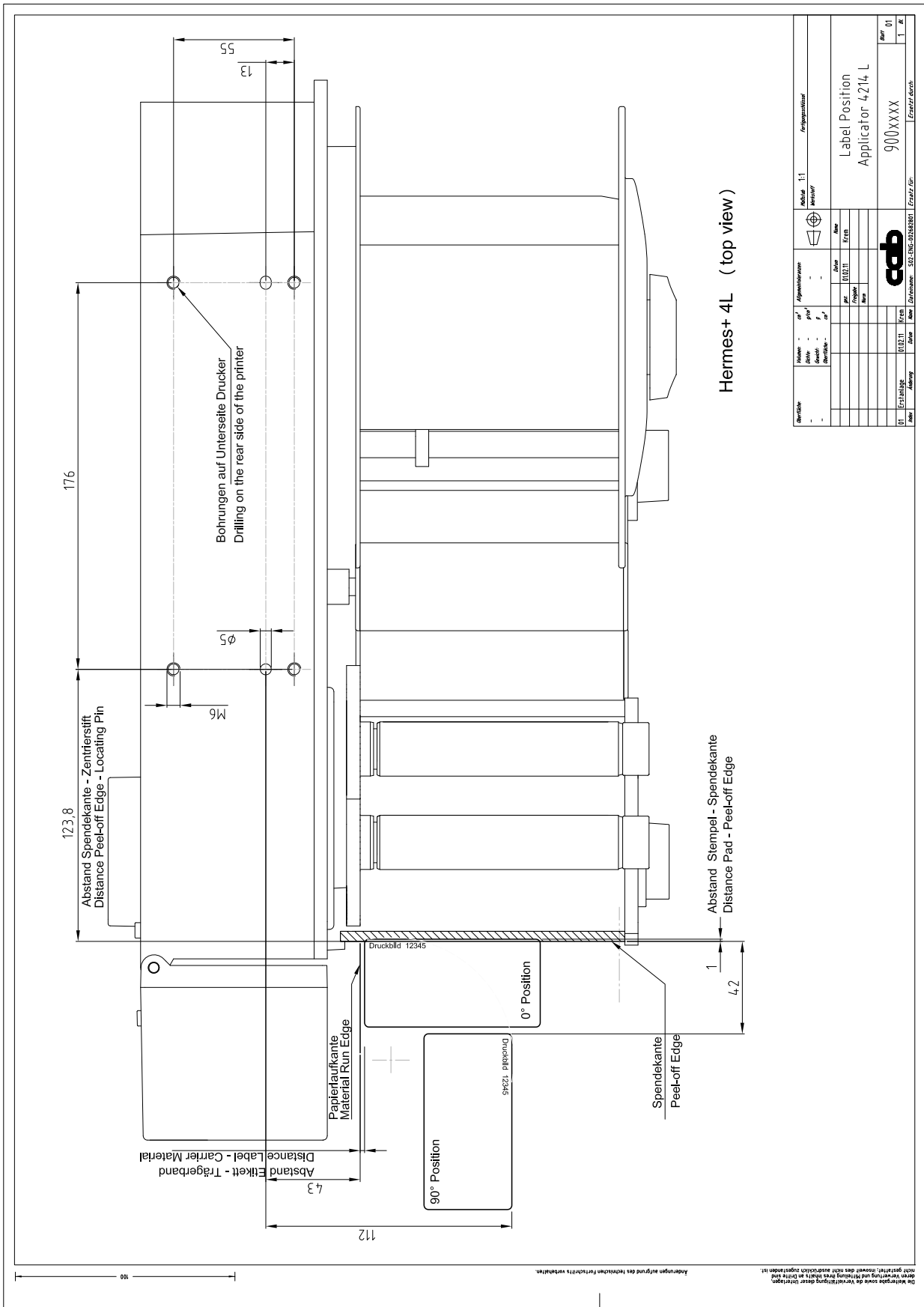

Fig. 45 Labeling position 4214L

9.5 Label Position Type 4214 R

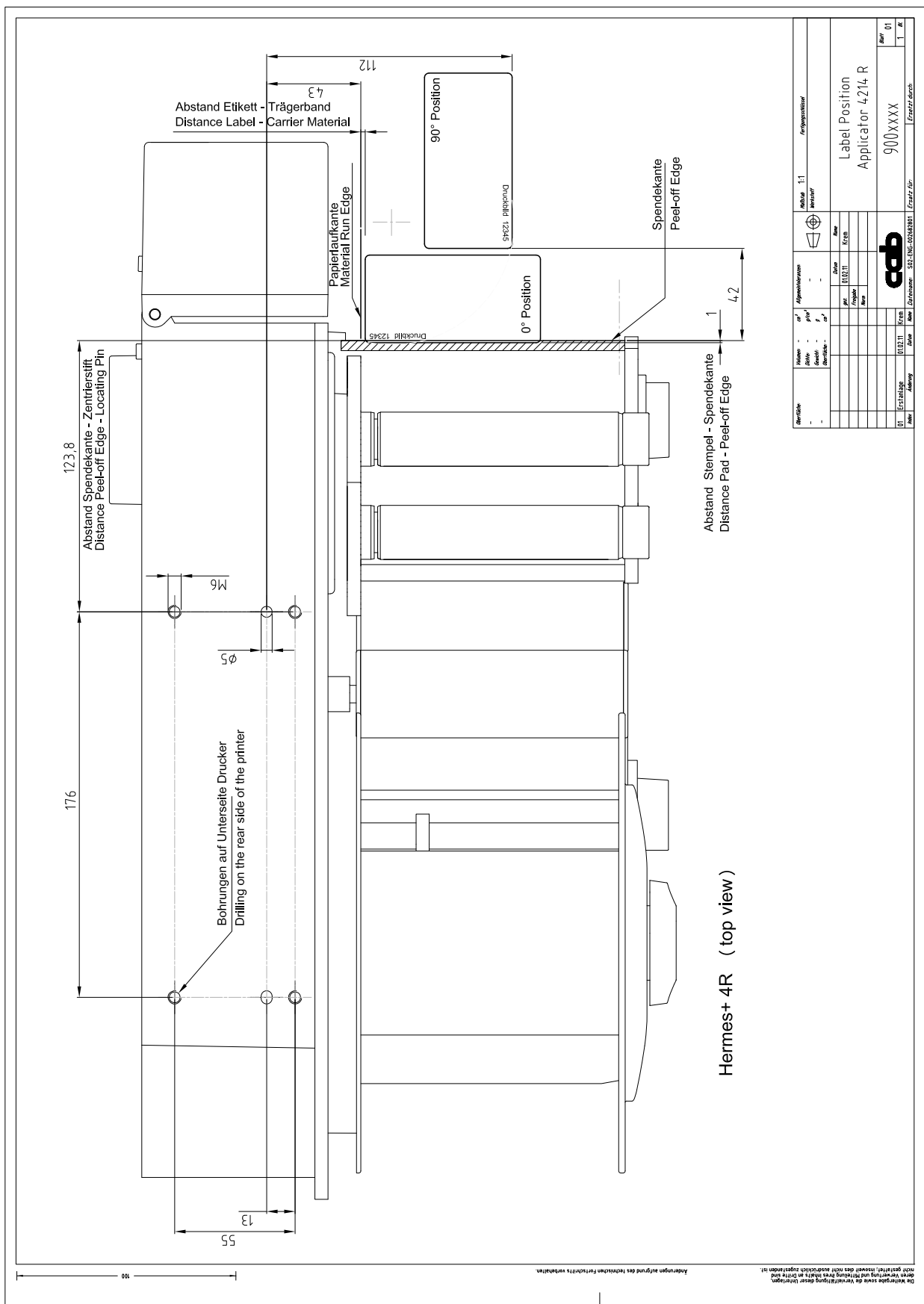

Fig. 46 Labeling position 4214R

- A**
- Abbau des Applikators..... 16
 - Apply/Print 35
 - Arbeitsdruck..... 6
- B**
- Block diagram..... 38
 - Blowing air 35
 - Blow on..... 34, 35
 - Blow time 35
 - Blow Tube
 - Mounting 17
- C**
- Cleaning 10
 - Compressed Air 18
 - Connect 18
 - Cover 15
 - Cylinder 23
- D**
- Dispensing plate 19
- E**
- End Position Cushioning 30
 - Etikettenbreite..... 6
 - Etikettenhöhe..... 6
- I**
- Intended use..... 4
- L**
- Labelling Sensor..... 29
 - Label position 4314R..... 40, 41
- O**
- Option..... 30
- P**
- Pad 19
 - Mounting 17
 - Pad in X-Direction..... 22
 - Pad in Y-Direction 20
 - Pad in Z-Direction..... 21
 - Parameters 35
 - Peel-off Mode 36
 - Peel Position..... 36
 - Pneumatics 39
 - Pneumatikplan..... 39, 41
 - Pressure reduction 30
 - Pressure reduction valve 30
 - Print/Apply 35
 - Printer Setup..... 34
 - Print Job 37
- R**
- Reading Point..... 24
 - Roll on 35
- S**
- Sensor / Mounting 23
 - Sensors 23
 - Sensor Start Position..... 29
 - Speed
 - Cylinder Y 31
 - Cylinder Z 28
 - Stamp on 34, 35
 - Starting position..... 35
 - Supporting air 35
 - Switch-off delay..... 35
 - Switch-on delay 35
- T**
- Taste feed (Drucker) 10, 13
 - Test Mode 37
 - Throttle Valves..... 23
- V**
- Vacuum..... 24
 - Vacuum sensor..... 35
 - Vorspendetaste..... 13
- W**
- Waiting position 35
- X**
- X-Direction..... 22
- Y**
- Y-Direction 20
- Z**
- Z-Direction 21
 - Zylinderhub..... 6