

Zebra Altiz 4200™

Product Reference Guide



ZEBRA

Copyrights, Trademarks, Patents, Limitations of Liability, and Disclaimers

This section lists copyrights, acknowledgments, patent notices, limitations of liability, and disclaimers.

Copyright

© 2024-2026 Zebra Technologies Corp. and/or its affiliates.

3 Overlook Point, Lincolnshire, Illinois 60069, USA

Proprietary Statement

This manual contains proprietary information of Zebra Technologies Corporation and its subsidiaries (“Zebra Technologies”). It is intended solely for the information and use of parties operating and maintaining the equipment described herein. Such proprietary information may not be used, reproduced, or disclosed to any other parties for any other purpose without the express, written permission of Zebra Technologies.

Trademarks

ZEBRA and the stylized Zebra head are trademarks of Zebra Technologies Corp., registered in many jurisdictions worldwide. All other trademarks are the property of their respective owners.

Patents

This product may be protected by one or more patents.

Patents: zebra.com/patents.

Limitations of Liability

In no event will Zebra or its suppliers be liable for any indirect, special, incidental, economic, cover or consequential damages arising out of the use of or inability to use the product, user documentation or related technical support, including without limitation, damages or costs relating to the loss of profits, business, goodwill, even if advised of the possibility of such damages. In no event will Zebra and its suppliers' liability exceed the amount paid by you, for the product.

Because some jurisdictions do not allow the exclusion or limitation of liability for consequential or incidental damages, the above limitation may not apply to you.

Product Improvements

Continuous improvements of products is a policy of Zebra Technologies. All specifications and designs are subject to change without notice.

Disclaimer

Zebra reserves the right to make changes in specifications at any time and without notice. The information provided by this document is believed to be accurate and reliable. However, neither Zebra nor its suppliers assume any responsibility for its use; or for any infringements of patents or other rights of third parties resulting from its use. No license is granted under any patents or patent right of Zebra.

Publication Date

January 2, 2026

Contents

Chapter 1: Before you begin..... 10

Zebra AltiZ 4200 overview	11
Zebra AltiZ 4200 features	13
Models available	14
Inspecting your Zebra AltiZ 4200 package	16
Base package	16
Starter kit package	16
Available separately	17
Software overview	18
Minimum requirements	21
Key to symbols, laser warnings, handling, and cleaning instructions	22
Zebra AltiZ 4200 safety precautions and key to symbols	22
Laser safety	23
General care and cleaning instructions	26
Documentation conventions and notes	26
Basic steps for using Zebra AltiZ 4200	27
Service Information	29
Zebra Vision Academy	29

Chapter 2: Powering and connecting to your Zebra AltiZ 4200..... 30

Zebra AltiZ 4200 installation steps	31
Zebra AltiZ 4200 mounting	32
Grounding Zebra AltiZ 4200 to earth ground	35

Acquisition considerations	36
Considerations to reduce image sensor occlusions	36
Considerations to reduce laser occlusions	37
Situations where multiple peaks are detected	38
Powering and connecting to your Zebra AltiZ 4200	39
Powering your Zebra AltiZ 4200 with PoE	40
Finding and naming your Zebra AltiZ 4200 using Aurora Imaging Capture Works	41
Adjusting Zebra AltiZ 4200 once mounted	42
Reading the state of your Zebra AltiZ 4200	43
Connecting to the auxiliary I/O interface	45
Connecting devices to the auxiliary output lines	46
Connecting devices to the auxiliary input lines	55
Connecting multiple auxiliary devices to Zebra AltiZ 4200	64

**Chapter 3: Step-by-step Zebra AltiZ 4200 configuration
with Aurora Imaging Capture Works 68**

Configuring Zebra AltiZ 4200 with Aurora Imaging Capture Works	69
Case 1: Quickly performing a single-profile scan with default settings	70
Case 2: Performing a single-profile scan with optimized settings	72
Case 3: Performing a multi-profile surface scan using a constant line (profile) rate	75
Case 4: Performing a multi-profile surface scan using an encoder	77

**Chapter 4: Understanding and setting the features of your
Zebra AltiZ 4200 80**

Steps to performing basic 3D scans with Zebra AltiZ 4200	81
Quick setup	82
Using the Zebra AltiZ 4200 GenICam features	83
Understanding how 3D depths and coordinates are established	84

Anchor coordinate system modes	86
Laser control and exposure	88
Modifying scan area, scan length, and scan step	89
Scan area	89
Scan length and scan step (displacement)	90
Positive versus negative displacement.	91
Specifying scan step when using a constant line (profile) rate	92
Specifying displacement when using a line (profile) trigger	93
A summary	95
Setting up frame triggers for single-profile scans or multi-profile surface scans	96
Using ObjectDetect as a trigger source	97
Setting up acquisition trigger delays	99
Zebra AltiZ 4200 data output components and their definitions	100
Group ID	101
Zebra AltiZ 4200 workflow	102
Distributed user sets	102
Intensity user set	103
Setup user set	104
Profile and Surface user sets.	105
Peak processing	106
Adjusting peak extraction settings	106
Adjusting peak selection settings	107
Adjusting the resolution along the X-axis	108
Correcting for Zebra AltiZ 4200 rotation	110
Outputting a point cloud or depth map	113
Vibration compensation	114

Increasing Zebra AltiZ 4200 acquisition speed	115
Increasing acquisition speed by reducing the scan area	115
Increasing acquisition speed using subsampling	115

Chapter 5: Zebra AltiZ 4200 GenICam feature reference..... 116

Zebra AltiZ 4200 GenICam features	117
As per the GenICam standard.....	117
Quick Setup Control	118
Trigger Control.....	121
Encoder Control.....	124
Object Detect Control	126
User Set Control.....	127
Scan 3D Control	129
Volume Control	134
Peak Extraction and Selection Control	136
Device Control	137
User Set Control	139
Image Format Control	142
Acquisition Control	146
Vibration Control.....	151
Object Detect Control	152
Light Control	153
Encoder Control	154
Digital IO Control	158
Counter and Timer Control	160
Logic Block Control	169
Software Signal Control	172

Transport Layer Control	172
GigE Vision Control.....	173
Test Control	174
Event Control	174
Event Acquisition Error Data Control.....	175
Event Acquisition Trigger Missed Control.....	175
Event Test Data Control	175
Chunk Data Control	176
File Access Control	181
Multi-AltiZ Plugin Control	182
Setup Control	182
Camera Control	183

Chapter 6: Using Zebra AltiZ 4200 with Aurora Imaging Library..... 186

Configuring Zebra AltiZ 4200 using Aurora Imaging Library	187
---	-----

Appendix A: Glossary..... 188

Glossary	189
----------------	-----

Appendix B: Technical reference..... 194

Zebra AltiZ 4200 general specifications	195
Electrical specifications	198
Mechanical and environmental specifications	199
Dimensions	200
Zebra AltiZ 4200 connectors	201
Digital I/O and power connector	202
2.5GBASE-T Ethernet connector	204

**Appendix C: Using Zebra Altiz 4200 3D sensors
in multi-altiz configuration 206**

Summary of multi-altiz configuration 207

Minimum requirements for Zebra Altiz 4200 multi-altiz configuration 208

Mounting Zebra Altiz 4200 in multi-altiz configuration 209

Wiring Zebra Altiz 4200 in multi-altiz configuration 211

Download and install the Zebra Altiz 4200 Multi-Altiz Plugin
on your computer 220

Add and setup the Zebra Altiz 4200 Multi-Altiz Plugin
on Aurora Imaging Capture Works 220

Alignment for multi-altiz configuration 222

 Create an alignment board 222

 How to align your multi-altiz configuration 223

Setting features in multi-altiz setup 225

Triggering in multi-altiz configuration 226

 Avoiding triggering conflicts 227

Performing a multi-profile surface scan in a multi-altiz configuration
using Aurora Imaging Capture Works 228

Appendix D: Listing of Zebra Altiz 4200 3D sensors 234

Key feature changes 235

Chapter

1

Before you begin

This chapter describes the features of Zebra Altiz 4200, safety precautions, and a description of the software that can be used with this device.

Zebra Altiz 4200 overview

Zebra Altiz 4200 (regulatory model AZ2) is a family of 3D profile sensors that use camera-laser triangulation (line profiling) to acquire high-precision 3D data. Zebra Altiz 4200 is interfaced using the GigE Vision 2.2 standard (or higher) over Ethernet (1000BASE-T or 2.5GBASE-T). Zebra Altiz 4200 can be used with any software that is compatible with GigE Vision and that supports GenDC, including Aurora Imaging Library. Zebra Altiz 4200 can also interface with other devices using its auxiliary digital I/O lines.

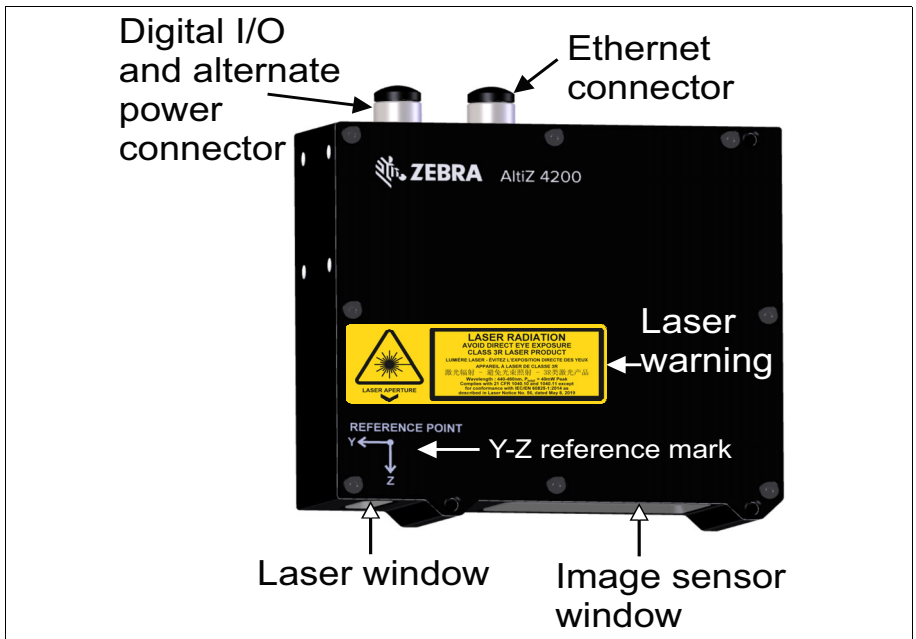

The diagrams below depict the fundamentals of laser line profiling.

Image sensor view of a slice

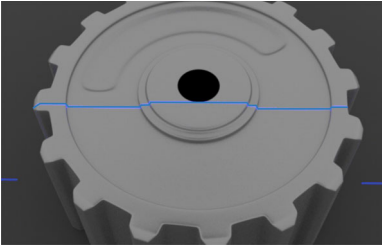

Point cloud of the slice (at a specific Y)



Point cloud of slices (at a Y up to this moment in scan)

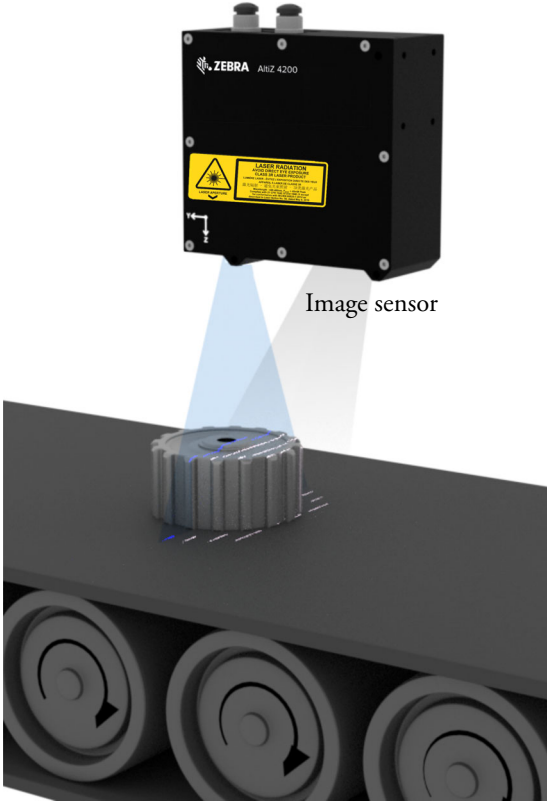
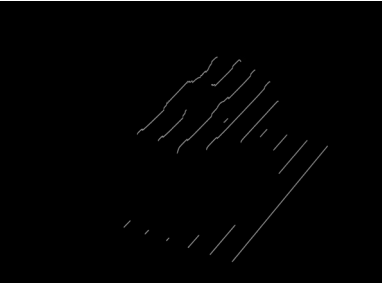

Note that in practice, you will take thousands of slices of the object

Zebra AltiZ 4200 features

Zebra AltiZ 4200 offers the following features:

- **On-device laser line processing.** Zebra AltiZ 4200 can establish the depth and reflectance of the surface of an object in a scene, using camera-laser triangulation. Zebra AltiZ 4200 can accumulate the 3D profiles of an object as it moves in front of the 3D sensor, and transmit a multi-profile surface scan or a single-profile scan, in either depth map or point cloud format.
- **Pre-calibrated.** Zebra AltiZ 4200 comes pre-calibrated from the factory for acquiring 3D data in real world distances, making installation and integration simple and fast.
- **Blue laser.** All Zebra AltiZ 4200 units use a blue laser with a wavelength of 450 nm. The blue laser reduces noise in the Z-axis.
- **Automatic triggering and object detection.** This feature allows you to define a region, within the field of view, to automatically detect objects and start acquisition without the need for an external trigger device (for example, a proximity sensor).
- **Auxiliary, multi-purpose I/O lines.** A total of 6 auxiliary lines (4 input lines and 2 output lines) are available, on which a variety of signals can be routed (for example, a profile trigger input with a user, timer, encoder, or propagated trigger output).
- **Power-over-Ethernet (PoE).** Zebra AltiZ 4200 supports being powered through its Ethernet cable.
- **Multiple mounting points and guide pin holes.** Zebra AltiZ 4200 can be mounted over conveyors, on robots, or a number of other industrial settings.
- **Zebra and third-party software compatible.** Zebra AltiZ 4200 can be used with any software that is compatible with GigE Vision 2.2 (or higher) and that supports GenDC, whether it be Aurora Imaging Library, one of its derivative, or third-party software. Zebra AltiZ 4200 also automatically enables support for the Zebra GigE Vision driver.

Models available

There are three models available in the Zebra AltiZ 4200 family of products, each with their own Field of View (FoV) and laser specifications.

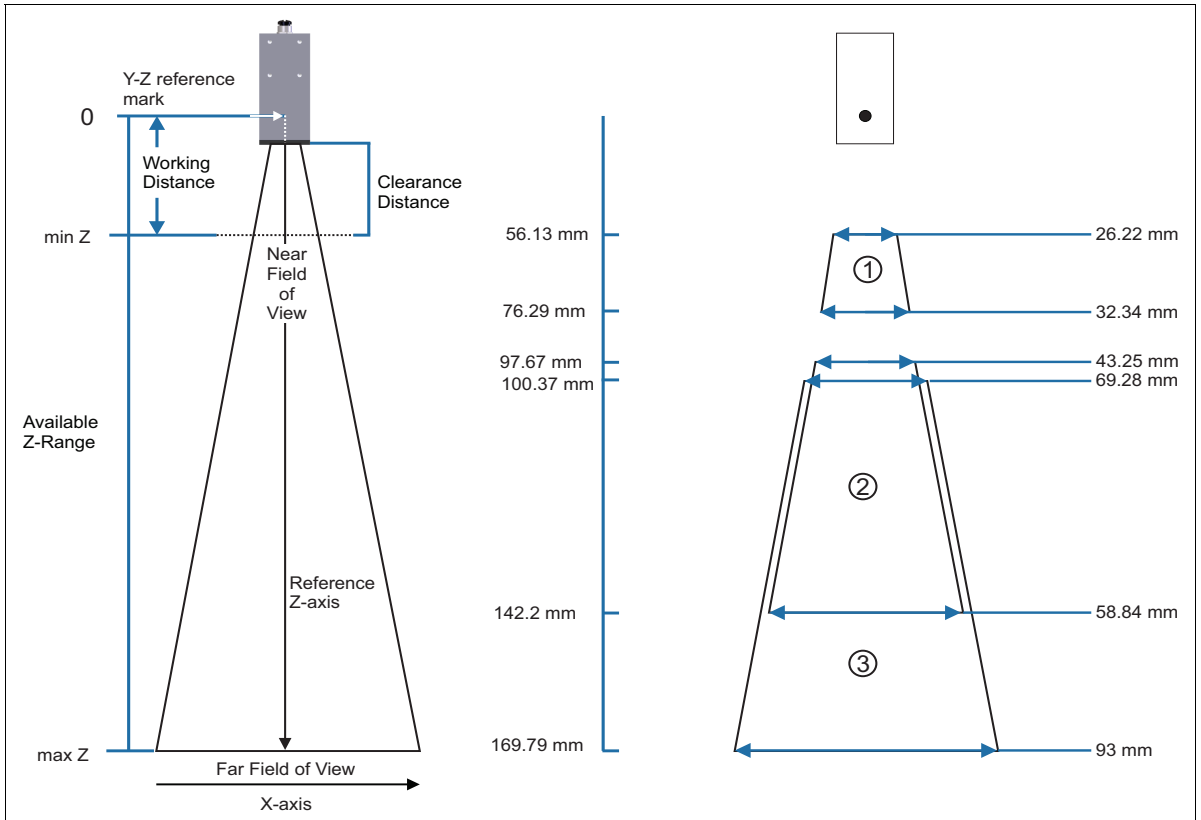

The table below details the FoV and laser specifications for each Zebra Altiz 4200 model.

Specifications	3D sensor model			
	AZ2S2SB (1)	AZ2S3SB (2)	AZ2S5SB (3)	
Laser color	Blue (450 nm)	Blue (450 nm)	Blue (450 nm)	
Laser class	3R	3R	3R	
Clearance distance (min) ^a	38.13 mm	79.67 mm	82.37 mm	
Working distance ^a (Y-Z reference mark to min Z)	56.13 mm	97.67 mm	100.37 mm	
Available Z-range	20.16 mm	44.53 mm	69.42 mm	
	min Z - max Z ^a	56.13 mm - 76.29 mm	97.67 mm - 142.20 mm	100.37 mm - 169.79 mm
Z-axis resolution (near-far) ^{a, b}	.757 μm - 1.152 μm	1.516 μm - 2.805 μm	2.396 μm - 4.315 μm	
X-axis Field of View (near - far) ^a	26.22 mm - 32.34 mm	43.25 mm - 58.84 mm	69.28 mm - 93 mm	
X-axis resolution ^{a, c}	6.21 μm - 7.65 μm	10.24 μm - 13.93 μm	16.40 μm - 22.02 μm	

- Note that these are approximate values and might slightly vary from unit to unit.
- Z-axis resolution values also include those resulting from sub-pixel processing. The sub-pixel algorithm used to derive these values was characterized with synthetic images. Be aware that sub-pixel processing produces varying results depending on the imaging conditions.
- Zebra Altiz 4200 outputs uniformly sampled data in the X-axis, which means the documented resolution in the X-axis is constant across the field of view (FOV). Therefore, the data density in the X-axis resolution is the same regardless of the elevation. By default, Zebra Altiz 4200 will use the resolution of the furthest end of the FOV when sampling data in the X-axis; you can increase the resolution up to that of the furthest end of the scan area.

Inspecting your Zebra AltiZ 4200 package

You should check the contents of your Zebra AltiZ 4200 package when you first open it. If something is missing or damaged, contact your Zebra sales representative.

Base package

If you have purchased Zebra AltiZ 4200, your package will include the following:

- Zebra AltiZ 4200 3D sensor.

Note that the Zebra AltiZ 4200 base package does not include any cables. To purchase cables, contact a Zebra sales representative.

Starter kit package

If you have purchased the Zebra AltiZ 4200 starter kit, your package will include the following:

- Zebra I/O Breakout Box for digital I/O and power connection.
- Power supply for the Zebra I/O Breakout Box.
- M12-CBL-ETH/5, a cable that supports both 1000BASE-T and 2.5GBASE-T, with an M12-X 8-position (male) connector on one end and an RJ-45 registered jack on the other. This cable is meant to connect your Zebra AltiZ 4200 to a computer or another network device, or provide power through PoE. For more details about this cable, refer to the *2.5GBASE-T Ethernet connector* subsection of the *Zebra AltiZ 4200 connectors* section, in *Appendix B: Technical reference*.
- M12-CBL-PWRIO/3, a digital I/O and power cable with an M12-A 12-position (male) connector on one end and open ended wires on the other. This cable is meant to connect your Zebra AltiZ 4200 to power and connect with third-party digital I/O devices.
- Zebra AltiZ 4200 mounting bracket.

Available separately

You might have also ordered one or more of the following products:

- M12-CBL-ETH/5, a cable that supports both 1000BASE-T and 2.5GBASE-T, with an M12-X 8-position (male) connector on one end and an RJ-45 registered jack on the other. This cable is meant to connect your Zebra AltiZ 4200 to a computer or another network device, or provide power through PoE. For more details about this cable, refer to the *2.5GBASE-T Ethernet connector* subsection of the *Zebra AltiZ 4200 connectors* section, in *Appendix B: Technical reference*.
- M12-CBL-PWRIO/3, a digital I/O and power cable with an M12-A 12-position (male) connector on one end and open ended wires on the other. This cable is meant to connect your Zebra AltiZ 4200 to power and connect with third-party digital I/O devices.
- M12-Y-CBL-MUL/2, a cable used to connect AltiZ 3D sensors in multi-Altiz mode and is referred to as the multi-altiz cable. This cable has an M12-A 12-position (male) connector on one end and two M12-A 12-position (male and female) connectors on the other end.
- Zebra I/O Breakout Box.
- Zebra AltiZ 4200 mounting bracket.

The following products are available from Phoenix GmbH & Co. KG:

- SAC-12-P-MS/3,0-PVC SCO, 1554788: An A-coded sensor/actuator cable, with an M12-A 12-position connector on one end and open wiring on the other.
- NBC-MSX/5,0-94F/R4AC SCO, 1407473: A 5m Ethernet CAT 6 (10 Gbps) network cable, with an M12-X 8-position connector on one end and an RJ45 connector on the other.

Software overview

Zebra Altiz 4200 can be used with any software that is compatible with GigE Vision 2.2 and supports GenDC with 3D, including Aurora Imaging Library and its derivatives (for example, Aurora Design Assistant and Aurora Imaging Library Lite). Zebra software is supported under Windows; Aurora Imaging Library is also supported under Linux. Consult your software manual for supported versions of these operating systems. Zebra Altiz 4200 includes royalty-free use of the Zebra GigE Vision driver. In addition, your Zebra Altiz 4200 comes with a Aurora Imaging Library Lite development license.

Aurora Design Assistant

Aurora Design Assistant is a flowchart-based, integrated development environment (IDE). It allows you to create an imaging application without writing a single line of code. Application development is a step-by-step approach, where each step is taken from an existing toolbox and is configured through a series of dialog windows. Aurora Design Assistant runs on your development computer and uses the resources of your Zebra Altiz 4200 (for example, to grab an image, acquire 3D data, and communicate with connected devices) to build projects. Once the project is built and deployed, it can run without the Aurora Design Assistant interface being installed.

With Aurora Design Assistant, you can:

- Create your project as a series of steps using a flowchart.
- Test your project from your computer without any additional code editors or compilers and without deploying (copying and running) your project on your Zebra Altiz 4200.
- Design and layout a web page (operator view) to receive operator input and to display your project's output.
- Run, terminate, and re-run the project on your Zebra Altiz 4200 from within Aurora Design Assistant.

Imaging projects can:

- Grab images and 3D data from cameras or 3D sensors or use images or 3D data from disk.
- Analyze images or 3D data using an extensive set of industry-proven image analysis and measurement tools (for example, code reader and Geometric Model Finder tools). Blob and edge analysis is also supported, along with color matching, code recognition, character recognition, bead inspection, measurement, metrology, 3D reconstruction, and an extensive set of additional processing and analysis features.
- Perform calibration for 2D images.
- Send and receive user-defined digital I/O signals (auxiliary I/O signals) controlled by software or by the timers in the Advanced I/O engine.
- Write image and text files (for example, CSV) locally or on network drives.
- Send and receive information and save images across the network using OPC-UA.
- Provide HMI user input and result display through configurable, web-accessible operator views.
- Send and receive information across the network using TCP/IP, Modbus, CCLink, EtherNet/IP, and PROFINET protocols
- Communicate with industrial robots to offer an integrated machine vision solution.

Aurora Imaging Library

Aurora Imaging Library is a high-level programming library with an extensive set of optimized functions for image capture, processing, analysis, transfer, compression, display, and archiving. Image processing operations include point-to-point, statistical, spatial filtering, morphological, geometric transformation, and FFT operations. Analysis operations support camera calibration, are performed with sub-pixel accuracy, and include pattern recognition (normalized grayscale correlation and Geometric Model Finder), blob analysis, edge extraction and analysis, measurement, image registration, metrology, character recognition (template-based and for both normal and

dot-matrix text, feature based), code reading and verification (1D, 2D, and composite code types), bead (continuous strips of material) inspection, 3D reconstruction, 3D processing, 3D analysis, classification, and color analysis.

Aurora Imaging Library applications are easily ported to new Zebra hardware platforms and can be designed to take advantage of multi-processing and multi-threading environments.

Aurora Imaging Library Lite

Aurora Imaging Library Lite is a subset of Aurora Imaging Library. It includes all the Aurora Imaging Library functions for image and 3D data acquisition, transfer, display control, and archiving. It also allows you to perform processing operations that are typically useful to preprocess grabbed images.

Aurora Imaging Capture Works

Aurora Imaging Capture Works is a utility that allows you to rapidly evaluate the performance and functionality of virtually any GenICam-compliant camera or 3D sensor (or other device). Aurora Imaging Capture Works will list all detected GigE Vision-compliant devices connected to your computer. It can start or stop capturing images, display acquired images, save the last grabbed image, send a software trigger, as well as browse and control the selected device's features. You can view network adapter information (such as, the IP address or packet size), view and change device information (such as, the user-defined name of your device), view and change acquisition properties, and view acquisition statistics. You can use it to configure the device and network adapter in static IP mode (or point-to-point connection mode) or DHCP mode (or corporate network mode). Aurora Imaging Capture Works uses the Zebra GigE Vision discovery service to automatically detect when GigE Vision-compliant devices are added to or removed from your network. Aurora Imaging Capture Works is distributed with Aurora Imaging Library and Aurora Design Assistant; it is also available with Aurora Imaging Library Lite.

Minimum requirements

The following lists the minimum requirements so that you can use your Zebra AltiZ 4200:

- A 1000BASE-T or 2.5GBASE-T Ethernet adapter¹, as well as installed and functioning Ethernet drivers.
- An Ethernet M12-X 8-position to RJ-45 cable that supports Ethernet Cat5e or better.
- A Zebra AltiZ 4200 digital I/O and power cable, plus a power supply.
 - ❖ Note that, if Power-over-Ethernet is used to power your Zebra AltiZ 4200, power comes over the Ethernet (M12-X 8-position to RJ-45) cable, and not over the Zebra AltiZ 4200 digital I/O and power cable.
- A computer running suitable GigE Vision-compliant software, such as Aurora Imaging Library or Aurora Design Assistant.





1. Operating with a 100 Mbit Ethernet connection might severely reduce the available acquisition frame rate; therefore, operating Zebra AltiZ 4200 at 1 Gbit/sec or above is highly recommended.

Key to symbols, laser warnings, handling, and cleaning instructions

You should be aware of the meaning of the symbols on Zebra AltiZ 4200 and important usage and handling precautions.

Zebra AltiZ 4200 safety precautions and key to symbols

Before installing, connecting to, and using Zebra AltiZ 4200, you shall be aware of the meaning of the symbols on the 3D sensor and important safety measures. The following is a list of precautionary symbols on the 3D sensor and their meaning:

Symbol ^a	Description
	The case of your Zebra AltiZ 4200 can become quite hot and should not be touched while operating. Always allow hot surfaces to cool down before touching your Zebra AltiZ 4200.
	<ul style="list-style-type: none"> Caution: Consult this manual^b before installing, connecting to, and using Zebra AltiZ 4200. For hardware connection instructions, refer to <i>Chapter 2: Powering and connecting to your Zebra AltiZ 4200</i>; for environmental and electrical specifications and connector pinout descriptions, refer to <i>Appendix B: Technical reference</i>. <p>This product must be used as specified; otherwise, the protection provided by its components might be compromised. Any usage, changes, or modifications to Zebra equipment not expressly approved by Zebra could compromise product safety and void the user's authority to operate the equipment.</p> <ul style="list-style-type: none"> Refer to the Electrical specifications section, of <i>Appendix B: Technical reference</i>, for voltages and current ratings. There are no serviceable parts on this product. In case of defect, contact your Zebra representative. All unused connectors on your Zebra AltiZ 4200 must be protected by connector caps. This product meets the requirements of a Category I installation as per industry standards^c. This product is designed for use in a pollution degree 2 environment as per industry standards^c. This product is designed for indoor use only. When powered using PoE+, Zebra 4Sight EV7, or an auxiliary power supply (24 Vdc +/-10%, 0.71 A), this product is designed to operate at temperatures ranging from 0°C to 45°C (32°F to 122°F) at a non-condensing relative humidity of 10 to 90%. When powered using PoE, this product is designed to operate at temperatures ranging from 0°C to 40°C (32°F to 104°F) at a non-condensing relative humidity of 10 to 90%. If the ambient temperature reaches over 45°C, the laser will shut off. This product is not intended for use at altitudes exceeding 2000 m.
	DC current only. Zebra AltiZ 4200 can be powered using a 24 V DC power supply (+/-10% tolerance, 0.71 A), an IEEE 802.3af compliant PSE device (44-57 VDC, 15.4 W), or an IEEE 802.3at compliant PSE device (50-57 VDC, 16 W).
	Earth ground. To ensure EMC conformity, connect the chassis ground hole of your Zebra AltiZ 4200 to earth ground.

a. Note that these symbols might not necessarily be the same color as depicted.

b. Manual available on the Zebra website at zebra.com/mv-manuals

c. As per CAN/CSA-C22.2 No 61010-1-12, UL std. No 61010-1 (3rd edition), and EN Std. No. 61010-1 (3rd Edition)

Laser safety

Zebra AltiZ 4200 incorporates a laser that is shaped into a line pattern, and has the potential to cause eye injury if it is mishandled. As such, the safety precautions outlined in this section are to be followed.

The laser used in Zebra AltiZ 4200 is Class 3R. Power to the laser is indicated visually by an LED on the 3D sensor. Zebra AltiZ 4200 is available in 3 different models; these models and their laser characteristics are outlined in the table below:

		Zebra AltiZ 4200 model		
		AZ2S2SB	AZ2S3SB	AZ2S5SB
Laser class		3R	3R	3R
Beam divergence				
	Full angle along line length	30° (0.52 rad)	30° (0.52 rad)	38° (0.66 rad)
	Full angle along line width	17.4 mrad	8.7 mrad	7.0 mrad
Wavelength		440 nm - 460 nm	440 nm - 460 nm	440 nm - 460 nm
Pulse duration		0 - 1 sec	0 - 1 sec	0 - 1 sec
Frequency range		1Hz-10 KHz	1Hz-10 KHz	1Hz-10 KHz

The housing of Zebra AltiZ 4200 must only be opened by authorized persons. For repair and service, Zebra AltiZ 4200 should always be returned to Zebra.

Caution

Use of controls, adjustments, or performance of procedures other than those specified herein might result in hazardous radiation exposure.

When operating Zebra AltiZ 4200, the relevant regulations according to EN60825-1 (IEC 60825, Part 1 of 05/2008), FDA 86-8260 and EN60825-1:2014/A11:2021 are required and all applicable accident prevention must be followed.

Laser Class 3R

Class 3R lasers emit radiation that can exceed maximum permissible exposure (MPE) under direct intrabeam viewing. Though the risk of injury is relatively low, direct intrabeam viewing is restricted. Accordingly, the following applies:

- Avoid direct eye exposure. Do not directly look into the laser beam, or direct it in areas where people are likely to directly view the beam.
- Avoid direct eye exposure to the reflection of the laser beam when it is reflected off a mirrored surface.
- Dazzle, flash-blindness, and after images might be caused by a beam from a Class 3R laser product, particularly under low ambient light conditions.
- Direct viewing into the beam with telescopic optical aids (for example, binoculars or telescopes) poses an eye hazard, and thus the laser should not be directed into an area where such instruments are likely to be used.
- Class 3R laser equipment can be used without additional protective measures as long as direct viewing, or viewing the beam through a mirror, is restricted. If you are working in an environment where the potential for direct exposure to laser radiation is likely, we recommend using eye protection with an optical density of 2.0 or higher.

The following information labels are fitted to the Zebra AltiZ 4200 housing and are found on the same side as the Y-Z reference mark. The labels will vary depending on your model of Zebra AltiZ 4200.

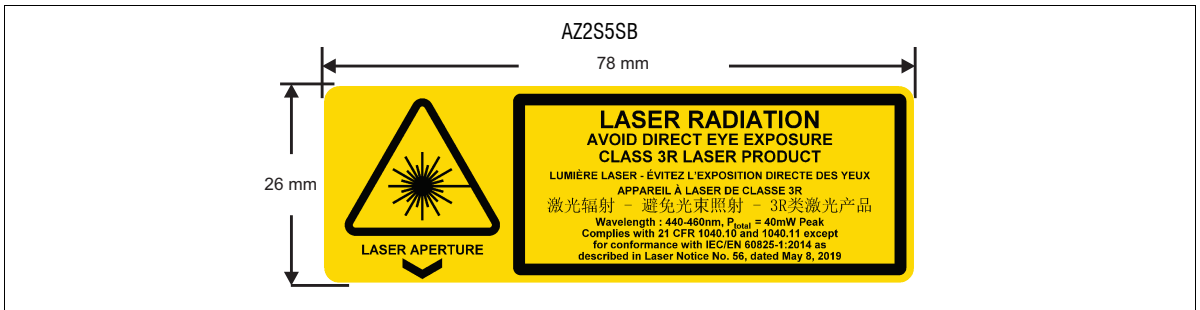
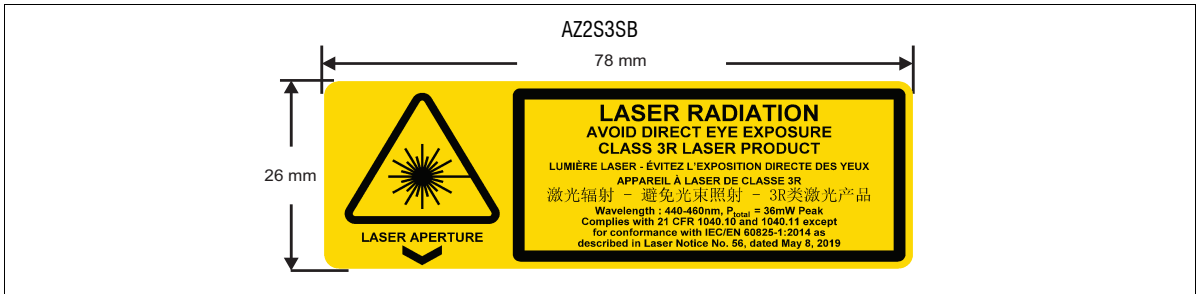
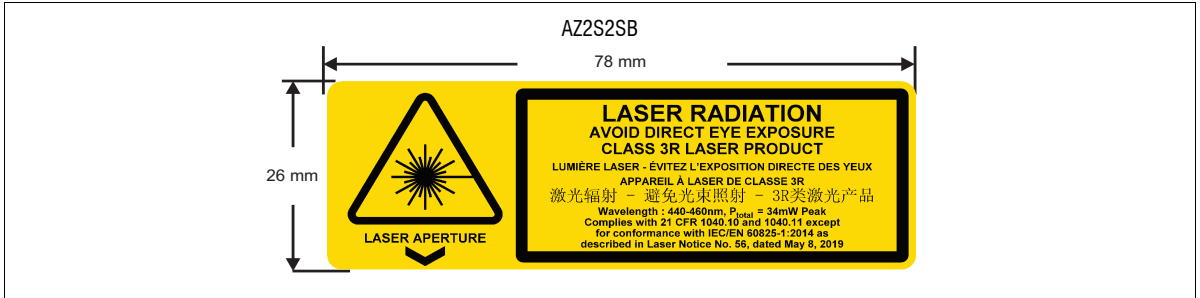

General care and cleaning instructions

If performing general maintenance on Zebra AltiZ 4200, ensure that Zebra AltiZ 4200 is powered down before beginning. When cleaning, the air must be free of oil, moisture, and other contaminants that could remain on the cleaned surface.

To clean the Zebra AltiZ 4200 housing, use a small amount of mild detergent cleaner on a cleaning cloth. Do not pour the cleaner directly onto the housing.

To clean the Zebra AltiZ 4200 optical sensor and laser windows, first use a dust free blower or a can of compressed air to blow any small particles off; then, wipe with a lint-free cloth wipe (for example, Kimwipes). A weak solvent can also be used, such as isopropyl alcohol, methanol, or acetone, to clean the windows. When using a solvent to clean the windows, use only a small amount on the lint-free cloth and allow it to dry by evaporation.

Documentation conventions and notes

Your Zebra AltiZ 4200 is a network-aware device. The terminology used throughout this document mirrors that of local area networks (LANs).

In this document, any computer that can communicate with your Zebra AltiZ 4200 is referred to as "your computer" or as a "controlling computer". If you use your computer to develop your applications for your Zebra AltiZ 4200, it is referred to as your development computer.

This document uses the term image sensor to refer to the physical image sensor in the unit or to its associated processing pipeline.

Useful to know

Note it is useful to use the bookmarks at the left (PDF TOC) and **CTRL+Shift+F** to navigate this PDF. The latter displays all instances of the searched term(s) in the PDF with a bit of context.

Basic steps for using Zebra AltiZ 4200

The following is a basic methodology for using your Zebra AltiZ 4200 3D sensor:

1. Install the latest version of Aurora Imaging Library, Aurora Imaging Library Lite, or Aurora Design Assistant. Aurora Imaging Capture Works will be included in the latest update of your Zebra software and will need to be used to setup Zebra AltiZ 4200. Alternatively, install a third-party software and follow their instructions for proper installation.

Important

If using a third-party software, ensure that your third-party software is compatible with GigE Vision 2.2 (or higher) cameras and supports GenDC.

2. Mount, power, and connect your Zebra AltiZ 4200, as described in *Chapter 2: Powering and connecting to your Zebra AltiZ 4200*.
3. Setup Zebra AltiZ 4200 either using Aurora Imaging Capture Works or a third-party software.
 - If using Aurora Imaging Capture Works to setup Zebra AltiZ 4200, follow the examples outlined in *Chapter 3: Step-by-step Zebra AltiZ 4200 configuration with Aurora Imaging Capture Works*. Then, for more detailed information, see the relevant sections in *Chapter 4: Understanding and setting the features of your Zebra AltiZ 4200*.
 - If using a third-party software, understand how to configure the features of your Zebra AltiZ 4200 so that they are appropriate for your use case. This includes adjusting the scan length, motion step, and other related features. To start, see the *Steps to performing basic 3D scans with Zebra AltiZ 4200* section in *Chapter 4: Understanding and setting the features of your Zebra AltiZ 4200*.
4. Once the features of your Zebra AltiZ 4200 are configured appropriately, you can save these settings to a writable user set: UserSet0, UserSet1, UserSet2, or UserSet3. To do so, use the `UserSetSave` feature. Note that by default, the non-writable Profile user set is loaded on reboot. You can change the user set that is loaded on reboot using the `UserSetDefault` feature.

5. After Zebra AltiZ 4200 is properly configured and the settings are saved to a user set, you can now use it to do 3D data processing in Aurora Design Assistant or Aurora Imaging Library.

This chapter and the remaining chapters in this manual describe how to setup and configure Zebra AltiZ 4200 in a single-device configuration. If you need to scan an object or a group of objects that are too large for one single Zebra AltiZ 4200, you can mount multiple Zebra AltiZ 4200 3D sensors to increase the available FoV. See *Appendix C: Using Zebra AltiZ 4200 3D sensors in multi-altiz configuration*. Before doing so, you should understand how to setup and configure Zebra AltiZ 4200 in a single-device configuration.

Service Information

If you have a problem with your equipment, contact Zebra Global Customer Support for your region. Contact information is available at: zebra.com/support. When contacting support, please have the following information available:

- Serial number of the unit
- Model number or product name
- Software/firmware type and version number

Zebra responds to calls by email, telephone, or fax within the time limits set forth in support agreements.

If your problem cannot be solved by Zebra Customer Support, you may need to return your equipment for servicing and will be given specific directions. Zebra is not responsible for any damages incurred during shipment if the approved shipping container is not used. Shipping the units improperly can possibly void the warranty.

If you purchased your Zebra business product from a Zebra business partner, contact that business partner for support.

Zebra Vision Academy

The Zebra Vision Academy online training resource is also available to help customers visualize the steps involved in using various products. Specialized Vision Academy videos provide guidance on basic and advanced steps used in working with Zebra AltiZ 4200. For access to these videos, visit the zebra.com/vision-academy.

Chapter

2

Powering and connecting to your Zebra Altiz 4200

This chapter guides you through mounting your Zebra Altiz 4200, powering the device, connecting it to your network, interpreting the indicator LEDs, and connecting to its auxiliary I/O interface.

Zebra AltiZ 4200 installation steps

This section outlines the basic steps necessary to get started with Zebra AltiZ 4200. Zebra AltiZ 4200 is factory calibrated; therefore, it does not need additional calibration for acquiring 3D data.

The following are steps to take to set up Zebra AltiZ 4200:

1. Mount Zebra AltiZ 4200 using the available mounting points. For information, see the *Zebra AltiZ 4200 mounting* section later in this chapter.
2. If necessary, connect devices to the digital I/O and power connector to send/receive auxiliary I/O signals to/from these devices. For information on connecting auxiliary devices, see the *Connecting to the auxiliary I/O interface* section later in this chapter.
3. Power Zebra AltiZ 4200 either using PoE over a network connection, or using auxiliary power. For information, see the *Powering and connecting to your Zebra AltiZ 4200* section later in this chapter.

Important

To achieve optimum precision, it is recommended to allow Zebra AltiZ 4200 to warm up for 20-30 minutes once it has been powered on, before you begin scanning.

4. Connect Zebra AltiZ 4200 to the network if you haven't already connected it for PoE.
5. Find Zebra AltiZ 4200 on your network using either Aurora Imaging Capture Works or your GigE Vision software of choice that supports GenDC with 3D data sets. For information, see the *Finding and naming your Zebra AltiZ 4200 using Aurora Imaging Capture Works* section later in this chapter.
6. If necessary, reposition Zebra AltiZ 4200 with the adjustment options available with your mounting bracket, to ensure the laser is being detected on the scanned object. It is recommended to use Aurora Imaging Capture Works while doing so, but third-party GigE Vision software can also be used. For information on how to do so using Aurora Imaging Capture Works, see *Case 1: Quickly performing a single-profile scan with default settings* section, in *Chapter 3: Step-by-step Zebra AltiZ*

4200 configuration with Aurora Imaging Capture Works. When using third-party software, see the *Adjusting Zebra AltiZ 4200 once mounted* section later in this chapter.

- ❖ Note that, if you need to scan an object or group of objects that are too large for one single Zebra AltiZ 4200, you can mount multiple Zebra AltiZ 4200 3D sensors to increase the available FoV. See *Appendix C: Using Zebra AltiZ 4200 3D sensors in multi-altiz configuration.* Before doing so, you should understand how to setup and configure Zebra AltiZ 4200 in a single-device configuration.

Zebra AltiZ 4200 mounting

Be sure to mount Zebra AltiZ 4200 before attaching any cabling. Zebra AltiZ 4200 provides 16 screw holes, with M4 threading, for mounting it in various positions; the mounting holes are found on the top, back, and sides of the 3D sensor. Zebra AltiZ 4200 also has 3 guide pin holes that provide precise alignment along secure guides.

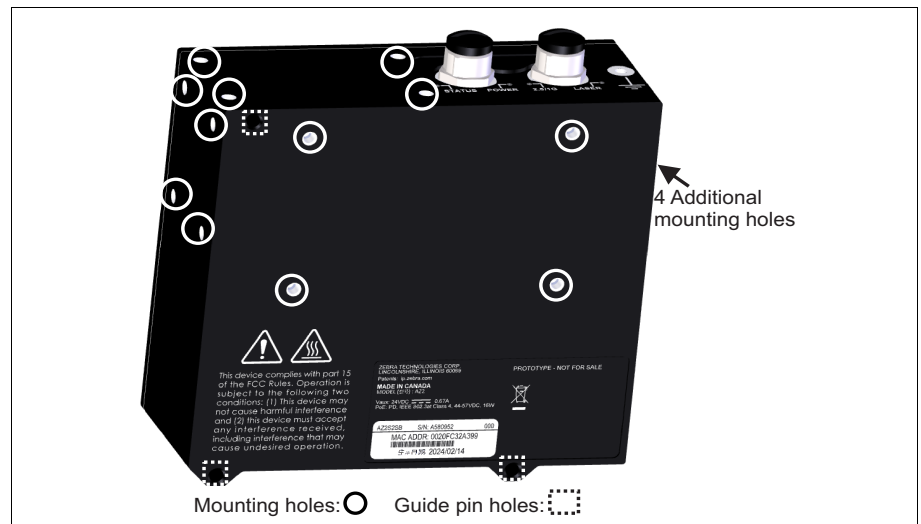

Important

When mounting Zebra AltiZ 4200, it is recommended to mount Zebra AltiZ 4200 to a material that dissipates heat, preferably some type of metal, such as steel.

The following diagram outlines possible mounting positions.

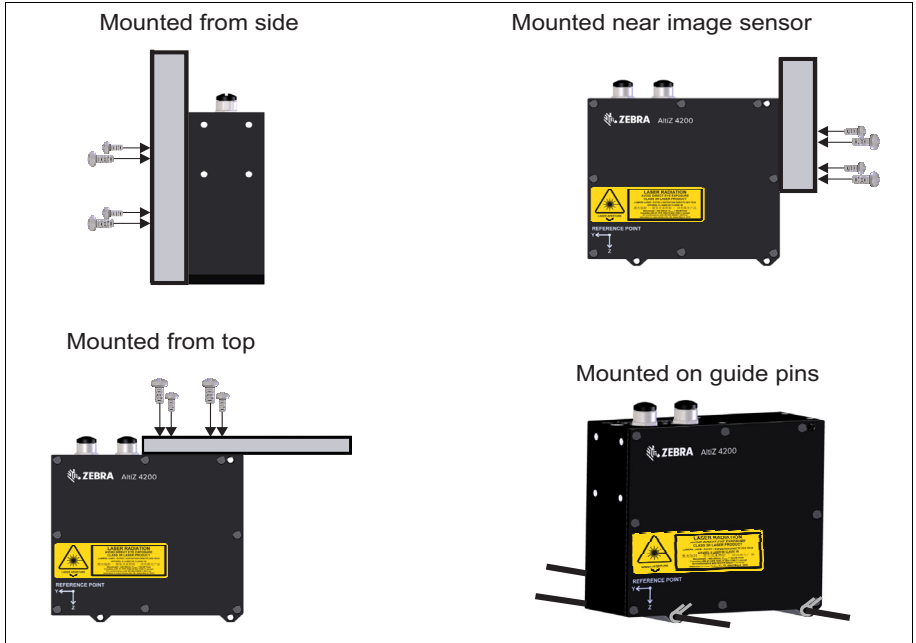

Important

When mounting Zebra Altiz 4200, ensure that the laser safety label remains visible during operation.

Mount Zebra Altiz 4200 at an appropriate distance from the objects to scan, based on the clearance distance of the model. Furthermore, when mounting Zebra Altiz 4200 using the side mounting holes, ensure that the bracket does not hang past the bottom of the 3D sensor so that it does not interfere with the beam of the laser.

With the guide pin holes, you are also able to group multiple Zebra Altiz 4200 3D sensors in parallel. This is useful if you need a wider scan. When mounting Zebra Altiz 4200 along guiding pins, ensure that a mechanism is put in place to prevent the 3D sensor from sliding along the pins (for example, using clamps) and that you use at least two guide pin holes to ensure your Zebra Altiz 4200 is securely mounted.

The orientation of Zebra AltiZ 4200 is important to consider when mounting. Regardless of where you mount Zebra AltiZ 4200, it is optimal that the direction of motion is always perpendicular to the laser plane. The following image illustrates how to optimally orient Zebra AltiZ 4200.

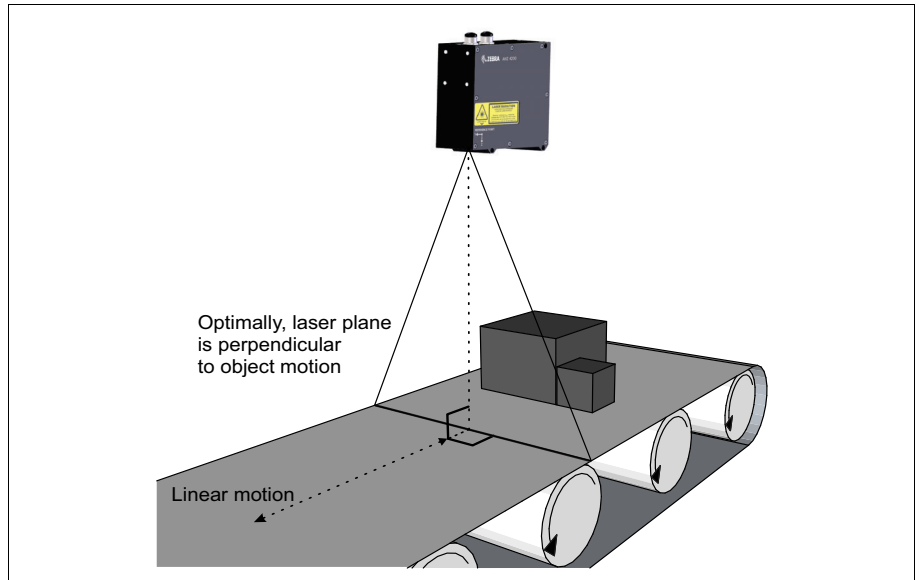

If your setup requires that the direction of motion is not perpendicular to the laser plane, you will need to correct the yaw around the Z-axis or the pitch around the X-axis, respectively. If the 3D sensor is only rotated around the Y-axis (normal of the laser plane), you don't need to adjust for yaw or pitch, but rather the rotation around the direction of motion. For best results in all cases, your setup should be as close as possible to the ideal setup described above. For information on how to correct yaw or pitch, see *Correcting for Zebra AltiZ 4200 rotation* section, in *Chapter 4: Understanding and setting the features of your Zebra AltiZ 4200*.

Grounding Zebra AltiZ 4200 to earth ground

Once Zebra AltiZ 4200 is mounted, you will also need to provide it a path to earth ground. There is a ground hole, found on the same face as the connectors, for you to ground Zebra AltiZ 4200. When selecting the screw to attach to the ground hole, ensure that it does not have any dielectric coating, or coating that could block the electrical path. For information on the dimensions of the ground hole, see *Dimensions* section, in *Appendix B: Technical reference*.

Important

To ensure EMC conformity, you must connect the ground hole of Zebra AltiZ 4200 to earth ground.



Acquisition considerations

To acquire accurate 3D profiles and point clouds, it is necessary to plan the scan path of the scanned object. This is important so that you can avoid occlusions and unwanted laser light reflections.

Considerations to reduce image sensor occlusions

Image sensor occlusions are situations where the image sensor cannot see the laser line. Examples of geometries with potential image sensor occlusions are provided below.

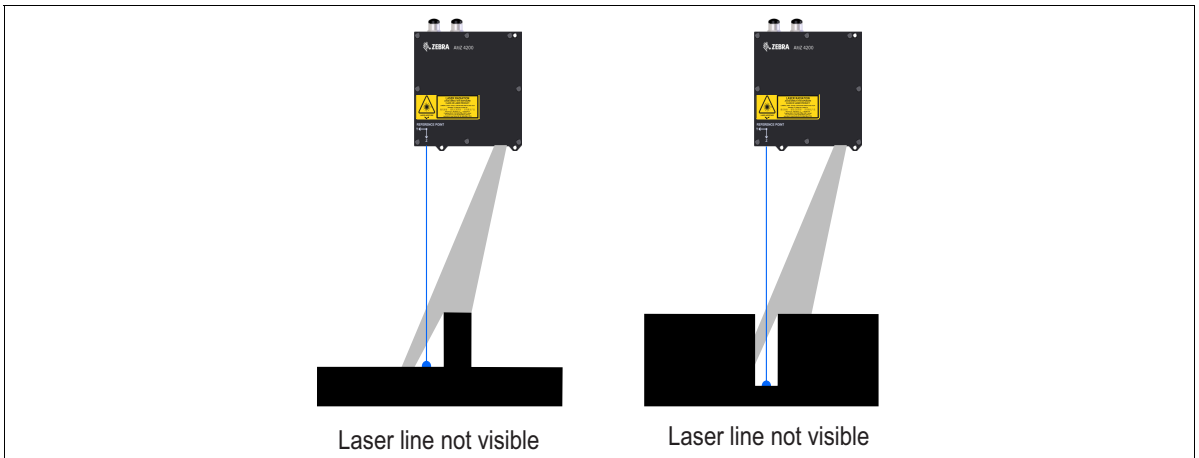
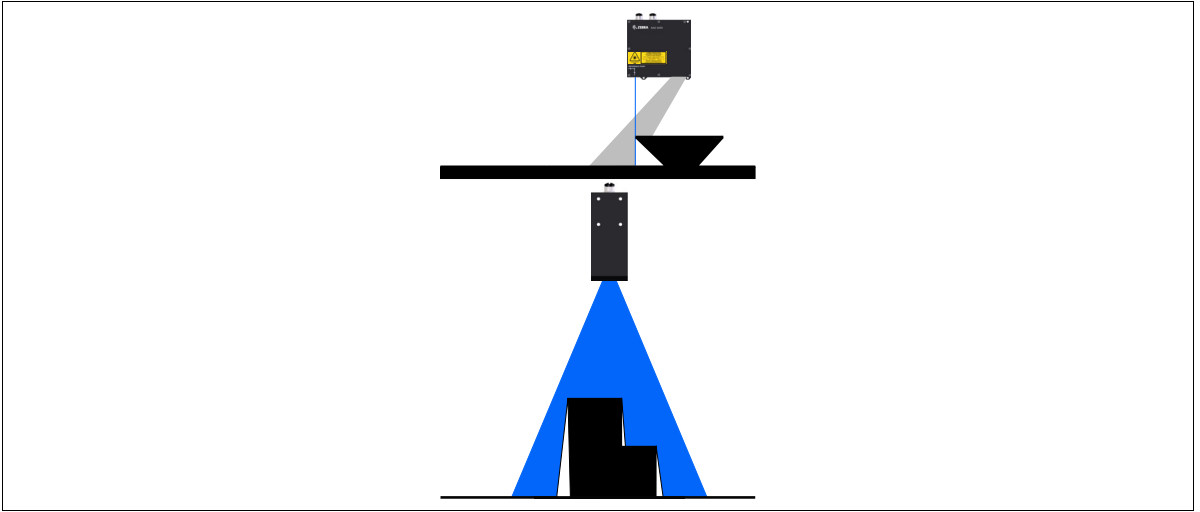

Image sensor occlusions can be addressed by adjusting the orientation of the object being scanned (or of Zebra AltiZ 4200), or mounting a second Zebra AltiZ 4200 to have multiple views. There are some cases where occlusions cannot be avoided, and you must make a decision as to which occlusions are most acceptable for your particular task.

Considerations to reduce laser occlusions

Laser occlusions are situations where the laser plane does not intersect with a certain part of the object. Examples of geometries with potential laser occlusions are provided below.



Since the laser plane should always be perpendicular to the scanned object, this is likely to happen to objects with indentations and curves, or along surfaces that are perfectly parallel to the laser plane. Adjusting the orientation of the scanned object is one way to help reduce laser occlusions.

Situations where multiple peaks are detected

You might find that even if the scanned object does not produce any occlusions, there might still be trouble acquiring points from certain materials because they produce multiple peaks that are detected by the image sensor. The diagram below depicts a situation where a reflective surface produces multiple peaks:

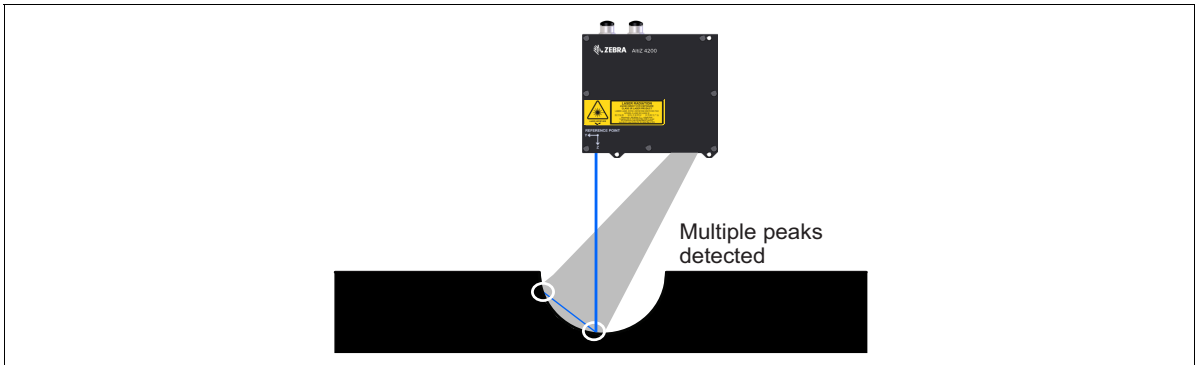

Detecting multiple peaks can be caused by the geometry, reflectance, and specularity of a material. In particular, objects with concave surfaces or sharp height transitions can cause multiple peaks to be detected; this can be made worse by the reflectivity of the surface.

Zebra AltiZ 4200 allows you to detect multiple peaks in the laser line image and select which is the actual laser line. You can use the following criteria to select the most accurate peak:

- Select the lower peak. Reflection is likely to come from the bottom of a surface and bounce upwards, making the false peak more likely to be found above the true peak. In this case, the lower peak will likely be the true peak.
- Select the narrower peak with a higher intensity. When a peak is reflected, the size generally appears wider and the peak is less intense than the true peak.

For information on how to set controls for peak size, location, and fusion results, see *Chapter 4: Understanding and setting the features of your Zebra AltiZ 4200*.

Powering and connecting to your Zebra Altiz 4200

Zebra Altiz 4200 has the following interfaces:

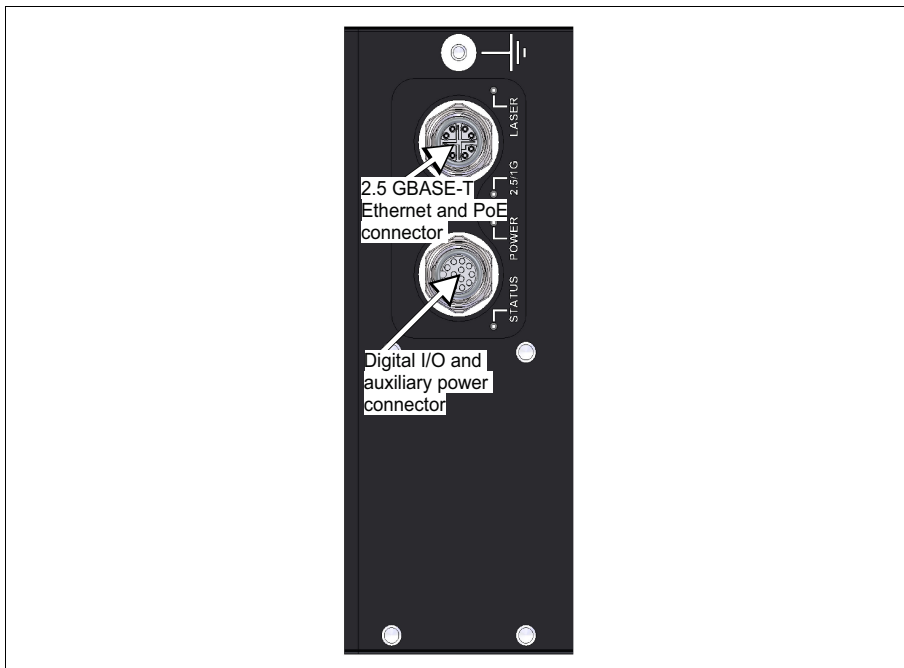

- **2.5GBASE-T and PoE connector.** This M12-X 8-position female connector provides connectivity between your Zebra Altiz 4200 and a computer or network. Zebra Altiz 4200 can gain access to a LAN via a 2.5GBASE-T Gbit Ethernet connection. This connector can also be used to receive power for your Zebra Altiz 4200 through the Ethernet cable (that is, Power-over-Ethernet (PoE)).
- ❖ Note that PoE requires that your network include some type of power sourcing equipment, such as a switch or injector that supports PoE, depending on your requirements.
- **Digital I/O and power connector.** This M12-A 12-position female connector is used to receive triggers (input), and user-defined auxiliary I/O signals to/from third-party I/O devices, over auxiliary I/O lines. This connector can also be used to receive power for your Zebra Altiz 4200 from an external auxiliary power source, if not using Power-over-Ethernet.

Powering your Zebra AltiZ 4200 with PoE

To power your Zebra AltiZ 4200 with PoE, connect the M12-X 8-position connector of the M12-CBL-ETH/5 network cable to the 2.5GBASE-T and PoE (M12-X 8-position) connector of your Zebra AltiZ 4200, and the RJ45 connector of the cable to the network connector of your network/computer. Ensure that connected to your network is a Zebra product that can supply PoE (for example, Zebra 4Sight EV7), or an appropriate third-party PoE injecting device. Once Zebra AltiZ 4200 is connected and powered, the power LED should turn solid green.

Important

After the power LED is solid green, wait 20-30 minutes before you begin scanning so that the laser of Zebra AltiZ 4200 can warm up to a stable temperature.

If you have not purchased the M12-CBL-ETH/5 network cable from Zebra, you will have to purchase an M12 8 position X-coded Ethernet male cable from a third-party. See the *2.5GBASE-T Ethernet connector* section, in *Appendix B: Technical reference* for details.

The following table describes the Power over Ethernet requirements for powering your Zebra AltiZ 4200.

Specifications	Power source		
	PoE	Zebra 4Sight EV	PoE+
Maximum cable length	30 m	30 m	100 m
Power available at the powered device ^a	12.95 W	15.2 W	17 W
Voltage	44-57 Vdc	44-57 Vdc	50-57 Vdc
Type/Class	1/3	1/3	2/4
IEEE Spec	802.3af	802.3af	802.3at
Maximum operating temperature ^b	40°C	45°C	45°C

- Using PoE+, Zebra 4Sight EV7, or an auxiliary power supply (24 Vdc +/-10%, 0.71 A) is required to adequately power the active cooling that is necessary for supporting a low laser temperature.
- At a non-condensing relative humidity of 10% to 90%.

If both PoE and auxiliary power (24 Vdc +/-10%) is provided, Zebra AltiZ 4200 will give priority to auxiliary power. For information about Zebra AltiZ 4200 power consumption, see *Electrical specifications* section, in *Appendix B: Technical reference*.

Powering your Zebra AltiZ 4200 with an auxiliary power supply

To power your Zebra AltiZ 4200 with auxiliary power, connect the M12-A 12-position connector of the M12-CBL-PWRIO/3 power cable to the Digital I/O and power connector of your Zebra AltiZ 4200 and the other end to your power supply. When powering from a 24 V +/-10% auxiliary power source, do not exceed a cable length of 5 m, since this will lower the quality of your signal. If you have not purchased the M12-CBL-PWRIO/3 cable from Zebra, use a custom cable with an M12-A 12-position connector to power Zebra AltiZ 4200 with auxiliary power. For the pinout and a description of the digital I/O and power connector, refer to the *Digital I/O and power connector* subsection of the *Zebra AltiZ 4200 connectors* section, in *Appendix B: Technical reference*.

Finding and naming your Zebra AltiZ 4200 using Aurora Imaging Capture Works

Once Zebra AltiZ 4200 is powered on, you should use Aurora Imaging Capture Works or your third-party GigE Vision software to find it on your network and, if necessary, name it. To use Aurora Imaging Capture Works, you must first install it. When you install your Zebra software (Aurora Imaging Library, Aurora Imaging Library Lite, or Aurora Design Assistant), Aurora Imaging Capture Works is automatically installed. Once installed, you can find and name your Zebra AltiZ 4200 as follows:

1. Launch Aurora Imaging Capture Works from the **Aurora Imaging Control Center** or by typing "Capture Works" in the **Windows Start** menu.
2. Under the **Tools** heading, click on **Aurora Imaging Capture Works**. The **Aurora Imaging Capture Works** utility opens.
3. Select the **GigE Vision** item from the tree structure. Once expanded, this tree will show all the GigE Vision cameras and 3D sensors that are connected to your network.
4. To name your 3D sensor, right-click on it and select **Rename**.
5. Network adapter settings need to be set. If using Aurora Imaging Capture Works, you network settings will automatically be optimized, or a fix will be proposed. If using a third party software refer to that software documentation for information on these settings.

Adjusting Zebra AltiZ 4200 once mounted

Once Zebra AltiZ 4200 has been mounted, powered, and found on your network, you should use Aurora Imaging Capture Works or your third-party GigE Vision software to ensure that the laser line is visible and falls properly across the width of the object being scanned and is perpendicular to the direction of motion. You might need to fine tune the placement of the 3D sensor relative to the object that you need to scan. For example, you might need to increase or decrease the distance between the 3D sensor and the object so that the base line and the highest points fall in the available Z-range. It is recommended to make these adjustments while Aurora Imaging Capture Works or your GigE Vision software is running so that you can see the effects of the adjustment. To follow an example on how to adjust the laser line of your Zebra AltiZ 4200 3D sensor, see *Case 1: Quickly performing a single-profile scan with default settings* section, in *Chapter 3: Step-by-step Zebra AltiZ 4200 configuration with Aurora Imaging Capture Works*.

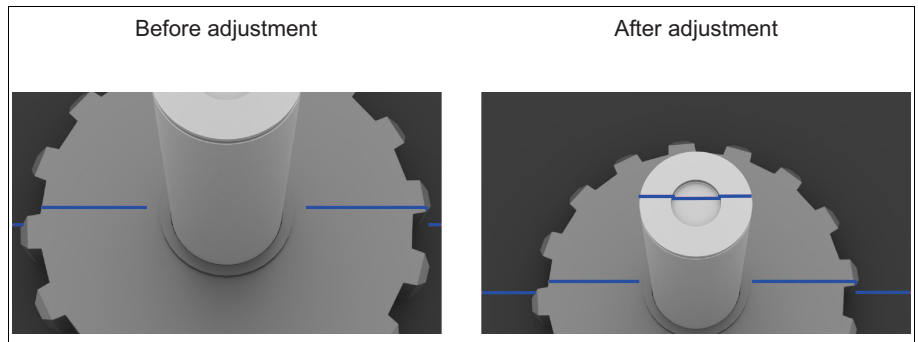

Ensure that you have adjusted Zebra AltiZ 4200 to properly account for the objects that you will scan before you begin full-time operation of Zebra AltiZ 4200.

Although Zebra AltiZ 4200 should be able to scan an image right out of the box with the default settings, if you find that after mounting and adjusting the 3D sensor you are still not able to see the laser line, you might need to adjust the exposure or other controls. For information on adjusting the exposure and ways to improve your 3D scan, see *Chapter 4: Understanding and setting the features of your Zebra AltiZ 4200*.

Reading the state of your Zebra Altiz 4200

From the moment you power up your Zebra Altiz 4200 to the moment you power it down, at least one of the four light-emitting diodes (LEDs) at the top of Zebra Altiz 4200 should be lit.



The LEDs on your Zebra Altiz 4200 are:

- **Status LED.** This LED shows the general activity of your Zebra Altiz 4200.

LED	Description
Off	Your Zebra Altiz 4200 has no power.
Solid red	Your Zebra Altiz 4200 is powered, but is in the process of initializing. This can also mean the FPGA is not programmed.
Solid orange	Your Zebra Altiz 4200 is initialized and waiting for acquisition start. The grab is idle.
Blinking orange-red	Your Zebra Altiz 4200 has encountered an error. Please call Zebra technical support.
Solid green	Your Zebra Altiz 4200 is waiting for a trigger. The acquisition started.
Blinking green	Your Zebra Altiz 4200 has acquisition activity. A trigger is received.

- **Power LED.** This LED shows the power and ready status of your Zebra Altiz 4200.

LED	Description
Off	Your Zebra Altiz 4200 has no power.
Solid red	Your Zebra Altiz 4200 is powered, but not initialized.
Solid orange	Your Zebra Altiz 4200 is initializing.
Solid green	Your Zebra Altiz 4200 is ready.
Blinking orange-red	Your Zebra Altiz 4200 is initializing or has encountered an error. Please call Zebra technical support if the LED continues to blink after sufficient time has been given for Zebra Altiz 4200 to boot.

- **2.5/1 G LED.** This LED shows the network connection status of your Zebra Altiz 4200.

LED	Description
Off	There is no network link between your Zebra Altiz 4200 and the network.
Solid red	There is a link using a low speed (10 or 100 Mbits) connection between your Zebra Altiz 4200 and the network.
Blinking red	The 10 or 100 Mbits/sec connection has activity.
Solid yellow	There is a link using the 1000 Mbits/sec connection.
Blinking yellow	The 1 Gbits/sec connection has activity.
Solid green	There is a link using the 2500 Mbits/sec connection (recommended).
Blinking green	The 2.5 Gbits/sec connection has activity (recommended).

- **Laser power LED.** This LED shows if the laser of your Zebra Altiz 4200 has power and whether it is emitting light.

LED	Description
Off	The laser has no power.
Blinking green	The laser is powered, but is not emitting light. By default, the laser is in automatic mode and will emit light as soon as it is triggered. Therefore, when this light is blinking green, the laser should be treated as though it is emitting light.
Solid green	The laser is powered and the laser is emitting light.

Connecting to the auxiliary I/O interface

Zebra Altiz 4200 has an auxiliary I/O interface with four capacitively isolated inputs and 2 opto-isolated outputs. Four of the lines are inputs which support sinking and sourcing configurations and can receive 24 V. Two are outputs which support sinking and sourcing configurations and support up to 24 V nominal.

Note that sinking and sourcing concepts refer to the *conventional current flow*, which means current flows from the positive potential towards the negative potential. A sinking device provides a path to *sink* current towards ground or to the *return path*; a sinking device does not provide power. A sourcing device provides a path that sources current; it provides a path from the power source. In the following diagram, the device on the right is the sourcing device, and the device on the left is the sinking device.

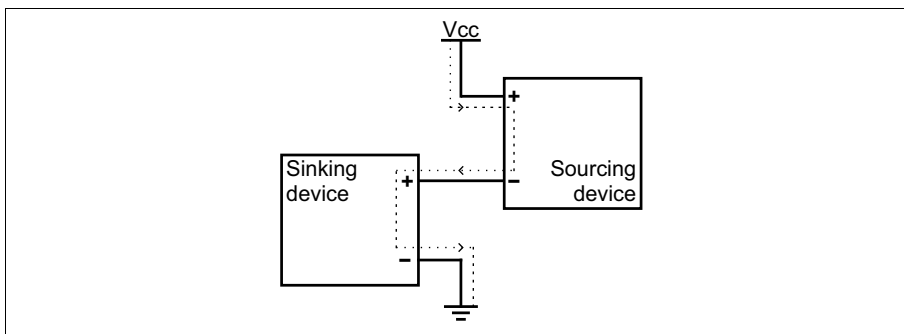

Equivalent circuit only

When setting up auxiliary I/O lines, be aware that you need to configure these pins on the software side as well. If you are using Aurora Design Assistant, refer to the *Using I/O steps with GigE/USB3 Vision cameras* section of the *I/O steps* chapter in the *Aurora Design Assistant help file* for this information. If you are using Aurora Imaging Library, refer to *Using Aurora Imaging Library with GenICam* section in the *Grabbing with your digitizer* chapter in the *Aurora Imaging Library help file*.

In this section and its subsections, the names of the auxiliary lines have been shortened in both the text and the diagrams. For output lines, the names have been shortened from AUX_ISOIND_OUT n to AUX_OUT and from

AUX_ISOIND_OUT_COM to AUX_OUT_COM. For input lines, the names have been shortened from AUX_ISOIND_IN_n to AUX_IN and from AUX_ISOIND_IN_COM to AUX_IN_COM.

Connecting devices to the auxiliary output lines

Zebra AltiZ 4200 auxiliary output lines can be interfaced with input modules (with sourcing or sinking input lines) found on most programmable logic controllers (PLCs) and other devices. The auxiliary output lines can also be interfaced with inductive load devices (such as a relay or a small motor).

The Zebra AltiZ 4200 auxiliary output lines are capacitor coupled. Each of the two available auxiliary output lines has one dedicated pin (AUX_OUT4 and AUX_OUT5) and shares a single common pin (AUX_OUT_COM).

You can connect the auxiliary output lines in a sinking or sourcing configuration. Since the auxiliary output lines share a common pin, they both have to be in a sinking configuration or both have to be in a sourcing configuration. The exact connection between the output line, the connected device, and the power source depends entirely on the type of device to which you connect. You should essentially connect your device respecting the following:

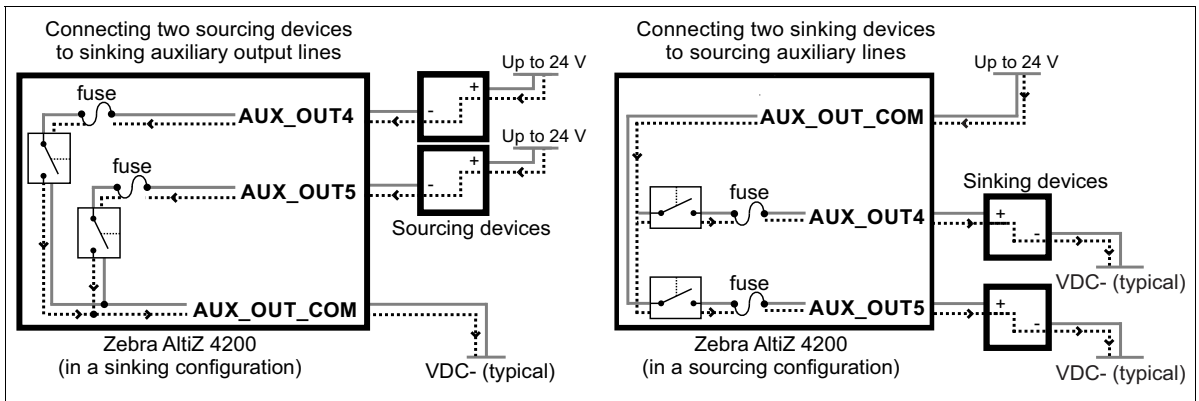

Equivalent circuit only

When the source signal of an auxiliary output line is **on**, the circuit between its AUX_OUT pin and AUX_OUT_COM pin is closed, allowing current to flow from the AUX_OUT pin to the AUX_OUT_COM pin or vice versa, depending on whether the AUX_OUT pin or AUX_OUT_COM pin is attached to a power source or a sourcing device. When the source signal of an auxiliary output line is **off**, the circuit between the AUX_OUT and AUX_OUT_COM pins is open and no current flows through.

Important

Note that the power source must be provided externally.

When an auxiliary output line is attached to a device, the following can be observed:

Connection	Observed at	Observed voltage	
		Signal on (closed so current can flow)	Signal off (open so current cannot flow)
Sourcing device attached to AUX_OUT pin and return path attached to AUX_OUT_COM pin	AUX_OUT pin	Low	Floating (voltage level is imposed by the sourcing device)
	AUX_OUT_COM pin	Low	Low
Power supply attached to AUX_OUT_COM pin and sinking device attached to AUX_OUT pin	AUX_OUT pin	High	Floating (voltage level is imposed by the sinking device)
	AUX_OUT_COM pin	High	High

Connecting to a digital device that requires two predictable voltage levels to operate

The auxiliary output lines can, therefore, only present one predictable voltage level for a given configuration: a low voltage level in a sinking configuration or a high voltage level in a sourcing configuration. Their other output state is, by default, floating. So, if you need to connect to a digital device that requires two predictable voltage levels to operate, pullup or pull-down circuitry must be added.

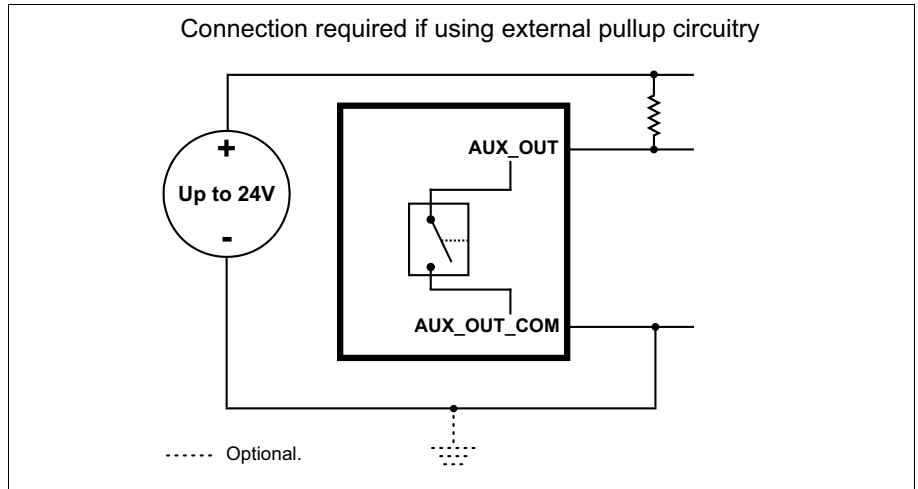

Equivalent circuit only

To add pullup or pull-down circuitry, attach an external pullup or pull-down resistor, respectively. A resistance value of 3 KOhms with a 1/4 W or greater resistor rating is suggested to protect your Zebra AltiZ 4200. Since your Zebra AltiZ 4200 auxiliary output lines can sink up to 30 mA, use the documentation of your input to calculate the required resistance for your external pullup/pull-down resistor (if necessary). To calculate the maximum pull-up resistance for your specific configuration, use the following equation:

$$R_{max} = \frac{Voltage - 11V}{2.8mA}$$

In the connections above, the pullup circuitry causes an inversion if the input of the device is connected to an AUX_OUT pin. When the source signal of the auxiliary output line is **on**, the circuit between its AUX_OUT and AUX_OUT_COM pins is closed, and current flows from the power source to the AUX_OUT_COM pin. So the observed voltage at the AUX_OUT pin will be low. Whereas, when the source signal of the auxiliary output line is **off**, the circuit

between its AUX_OUT and AUX_OUT_COM pins is open, and current flows from the power source to the input of the device. In this state, the current is limited by the pullup's resistor value.

Warning

The Zebra AltiZ 4200 auxiliary output lines are compatible with voltages up to 24 V. However, by default, the auxiliary output lines offer low resistance. When their circuit is closed (**on**), current flows directly through them. Ensure that the circuit created between the power source, the output line, the connected device, and return path does not cause more than 30 mA to flow through the line.

As a precaution, the auxiliary output lines are individually fuse-protected up to 30 mA. Zebra AltiZ 4200 uses resettable fuses. The fuses protect Zebra AltiZ 4200 if you accidentally connect their corresponding auxiliary output line to a device that sources/sinks more current than Zebra AltiZ 4200 can safely transmit. If more than 30 mA of current goes through your Zebra AltiZ 4200, the fuse will eventually trip. After disconnecting your Zebra AltiZ 4200 from your device, the fuse will reset only after it has sufficiently cooled.

The diagram below depicts Zebra AltiZ 4200's on-board fuse.

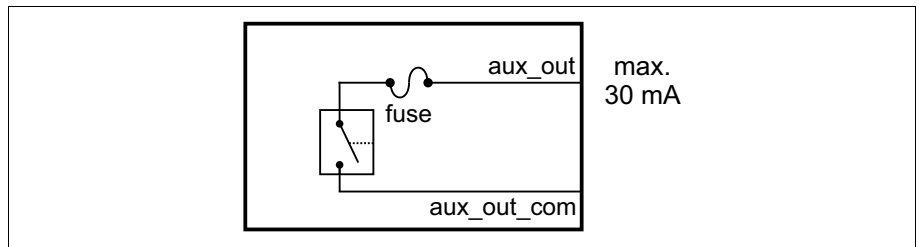

Equivalent circuit only

Opto-isolated output lines

The Zebra AltiZ 4200 auxiliary output lines are opto-isolated from the power as well as from the Zebra AltiZ 4200 auxiliary input lines. They are not, however, capacitively isolated from each other as they share a common pin (AUX_OUT_COM).

About the connections in the following subsections

The following subsections detail how to connect the most common third-party devices to the Zebra AltiZ 4200 auxiliary output lines. Ground is only shown in the following subsections for reference, in case you need to reference your return path to ground.

Power, as depicted in the following diagrams, represents a nominal voltage of up to 24 V (+/-10%). For minimum and maximum voltage requirements, refer to the electrical specification of the opto-isolated output lines, in *Appendix B: Technical reference*.

Connecting an auxiliary output line to a sourcing input

Connect a Zebra Altiz 4200 auxiliary output line to a sourcing input, as shown below.

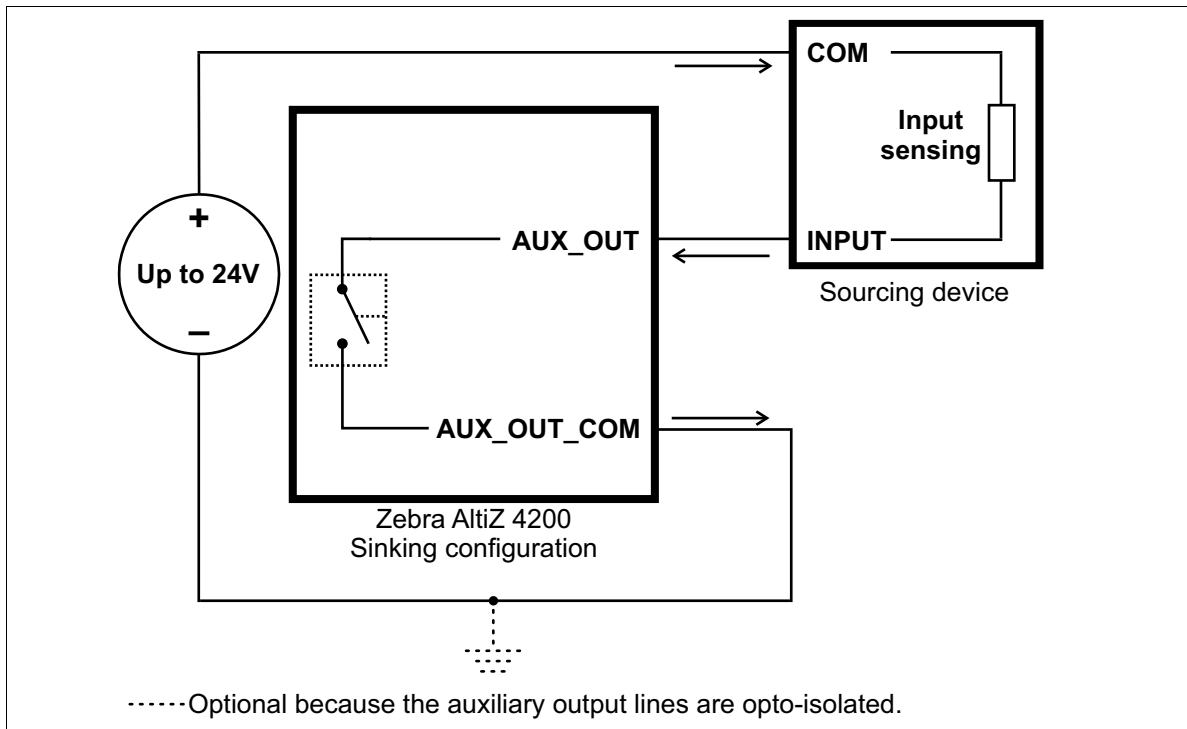

Equivalent circuit only

- ❖ Note that, when connecting a resistive load sourcing device instead of an input sensing sourcing device, use the same connection as displayed above.

Connecting an auxiliary output line to a sinking input

Connect a Zebra AltiZ 4200 auxiliary output line to a sinking input, as shown below.

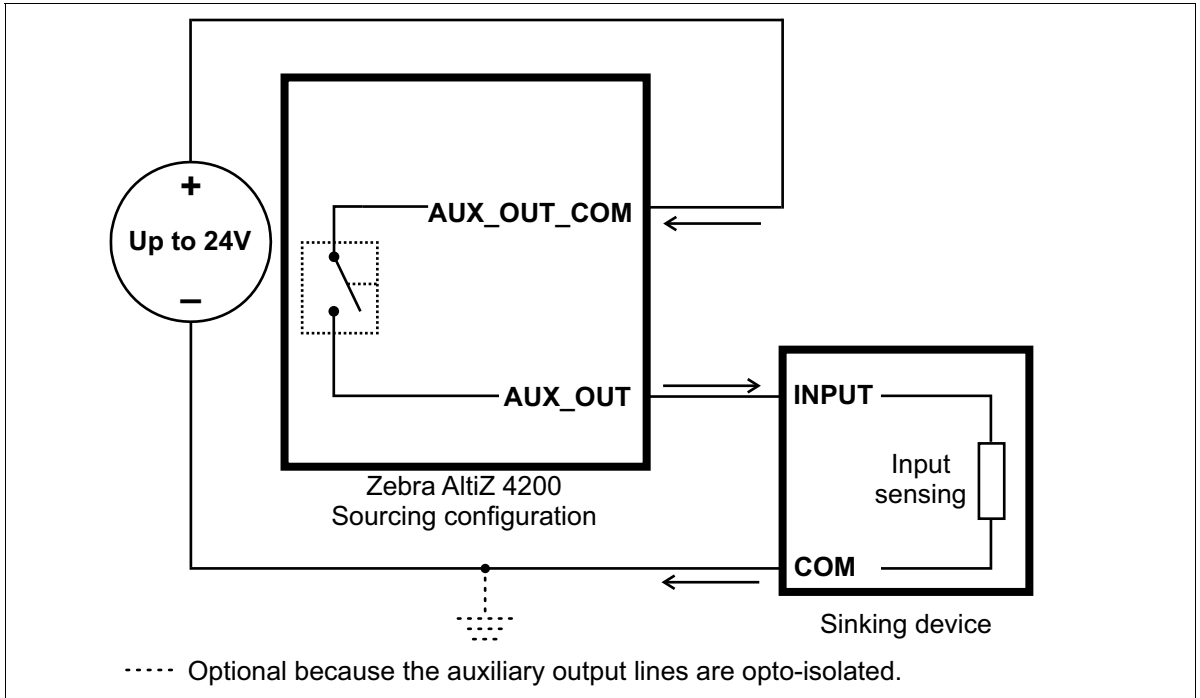

Equivalent circuit only

- ❖ Note that, when connecting a resistive load sinking device instead of an input sensing sinking device, use the same connection as displayed above.

Connecting an auxiliary output line to a sinking input using an external pullup resistor

Connect a Zebra AltiZ 4200 auxiliary output line to a sinking input using an external pullup resistor, as shown below. Since your Zebra AltiZ 4200 auxiliary output lines can sink up to 30 mA, use the documentation of your sinking device to calculate the required resistance for your external pullup resistor (if necessary).

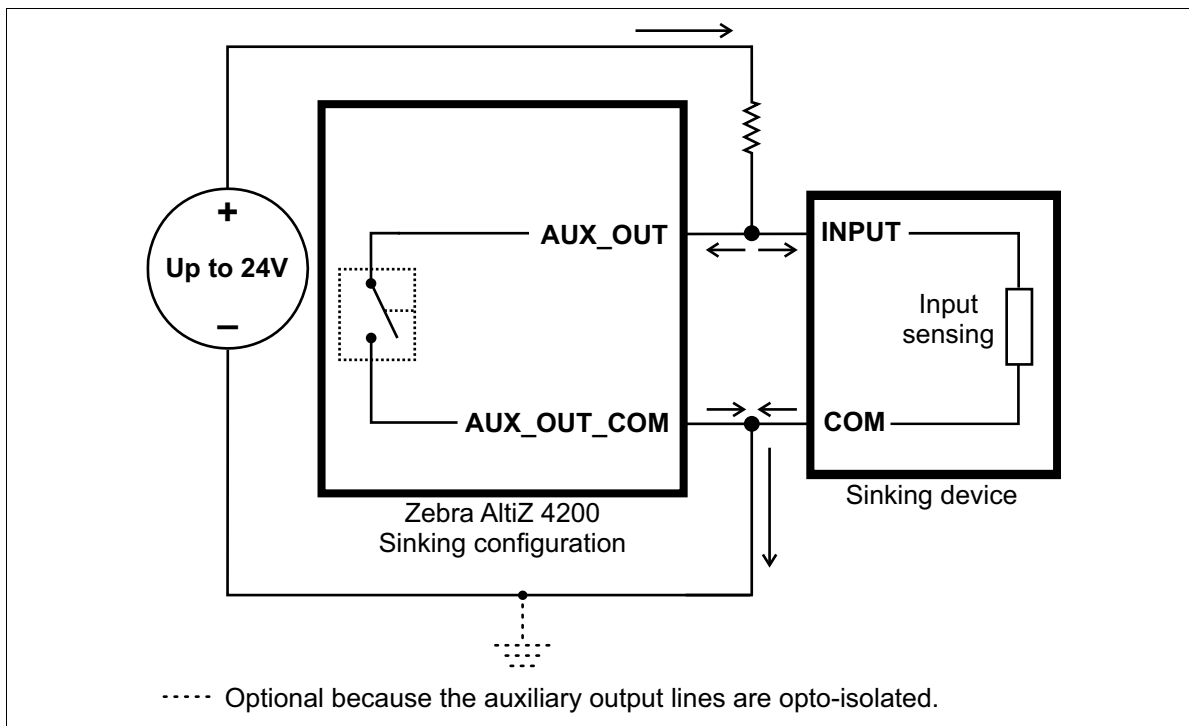

Equivalent circuit only

Connecting an auxiliary output line to an inductive load input

Connect a Zebra AltiZ 4200 auxiliary output line to an inductive load input, as shown below.

An inductive load device, such as a traditional relay, requires that you use a flyback diode to protect Zebra AltiZ 4200 from over and under-voltage, as shown below. This diode should be connected as close as possible to the input and voltage source of your inductive load device.

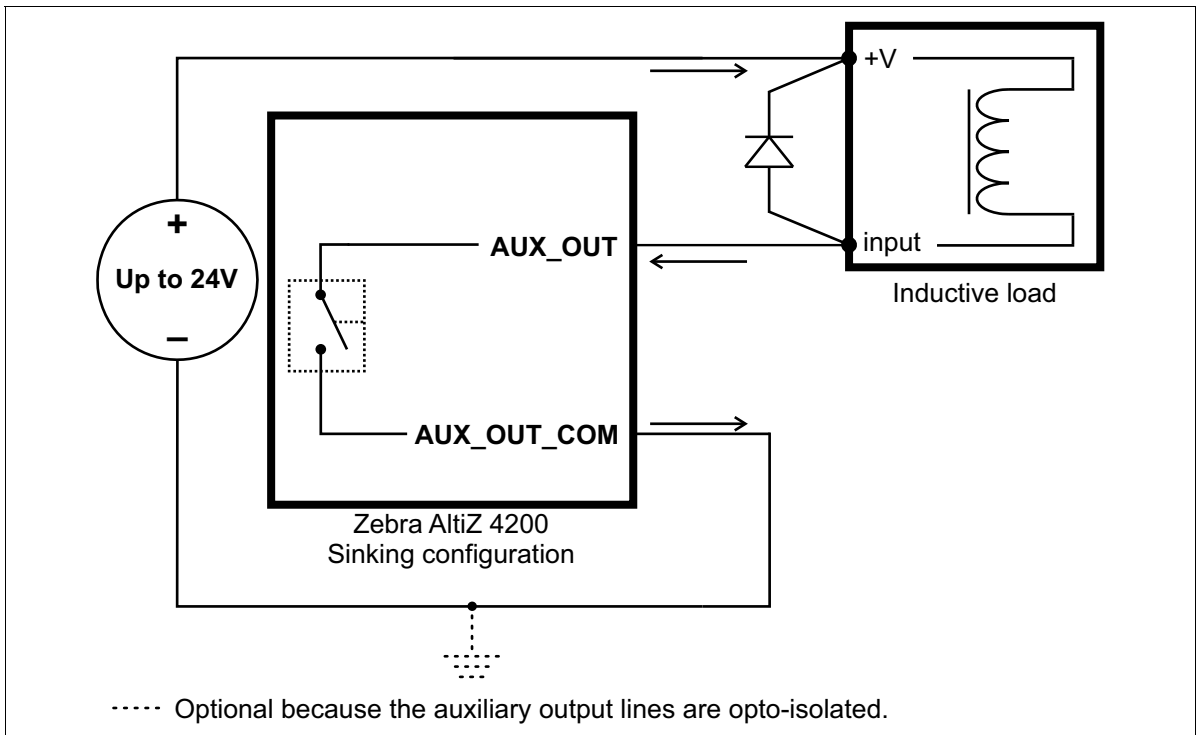

Equivalent circuit only

Connecting devices to the auxiliary input lines

Zebra Altiz 4200 auxiliary input lines can be interfaced with a wide variety of devices (such as proximity detectors). The Zebra Altiz 4200 auxiliary input lines only detect when current flows between their AUX_IN pin and AUX_IN_COM pin. As such, an auxiliary input line must be connected to a device that controls the flow of current. When current is detected, the signal is reported as **on**; otherwise, it is reported as **off**. For information on the electrical specifications of the **on** and **off** voltage levels, see the *Electrical specifications* subsection of the *Electrical specifications* section, in *Appendix B: Technical reference*.

Each of the four available auxiliary input lines has one dedicated pin (AUX_IN0, AUX_IN1, AUX_IN2, and AUX_IN3, respectively) and shares its other pin (AUX_IN_COM) with the other auxiliary input lines.

You can connect the auxiliary input lines in a sinking or sourcing configuration. Since the auxiliary input lines share a common pin, they have to be all in a sinking configuration or all in a sourcing configuration. The exact connection between the input line, the connected device, and the power source depends entirely on the type of device to which you connect. You should essentially connect your device respecting the following:

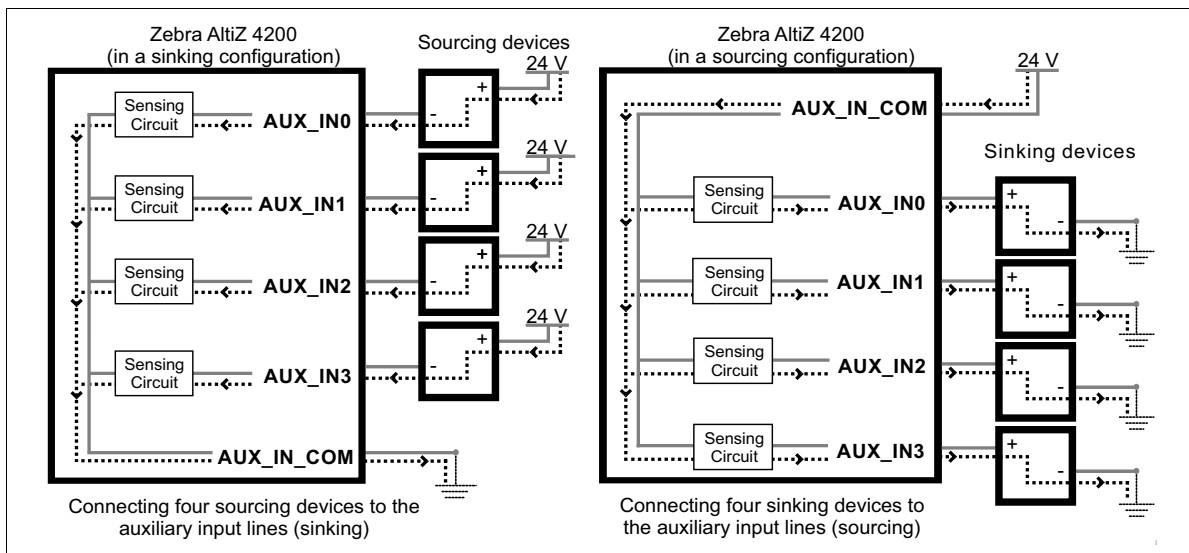

Equivalent circuit only

Pullup circuitry

In some cases, you must add pullup circuitry to connect an output device to an auxiliary input line; specifically, you must attach an external pullup resistor between the voltage source and the AUX_IN pin.

This is required when you connect the AUX_IN_COM pin to the electrical return path and the third-party output device is in a sinking configuration. In this case, select a resistor value that will not overcurrent the output device and instead provide just enough current and voltage to your Zebra AltiZ 4200 auxiliary input lines, according to the *Electrical specifications* section, in *Appendix B: Technical reference*. Note that you should use a resistor with an appropriate power rating for your circuit.

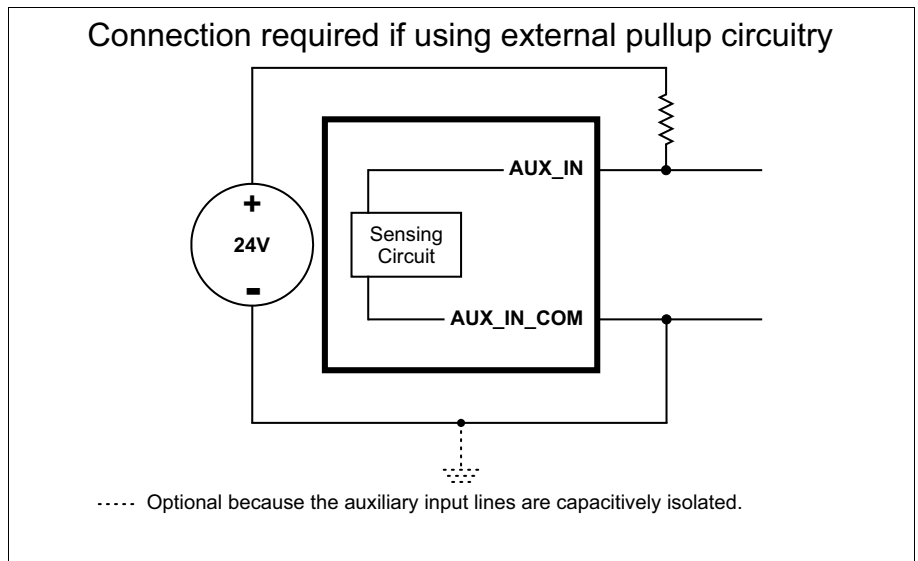

Equivalent circuit only

Bleeding resistor

By default, if properly configured, the current should flow from the AUX_IN pin to the AUX_IN_COM pin (when connected to a sourcing device), or from the AUX_IN_COM pin to the AUX_IN pin (when connected to a sinking device). In some cases, the amount of current going through the sensing circuit is insufficient for the connected output device to match its minimum current requirement when the device is in an on or off-state, depending on the configuration of the circuit. To boost the flowing current, connect a 2.2 kOhm external bleeder resistor between the AUX_IN and AUX_IN_COM pins. For example:

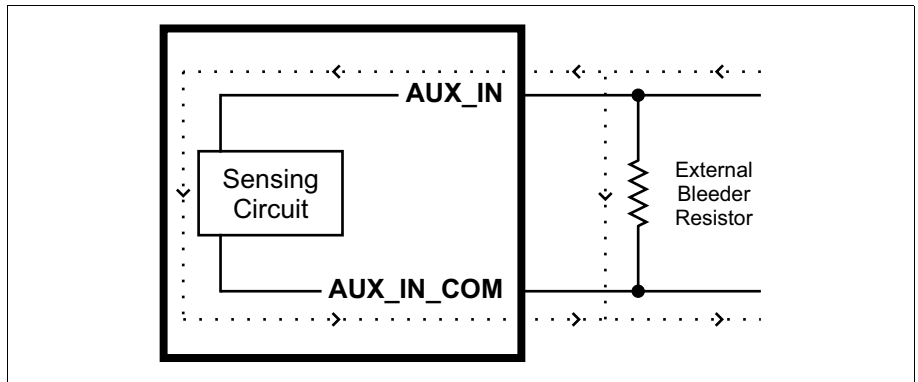

Equivalent circuit only

About the connections in the following subsections

The following subsections detail how to connect the most common third-party devices to the Zebra Altiz 4200 auxiliary input lines.

Note that Zebra Altiz 4200 auxiliary input lines are capacitively isolated. Ground is only shown in the following subsections for reference, in case you need to reference your return path to ground.

Power, as depicted in the following diagrams, represents a nominal voltage of 24 V (+/-10%). For minimum and maximum voltage requirements, refer to the electrical specification of the capacitor isolated auxiliary input lines, in *Electrical specifications* section, in *Appendix B: Technical reference*.

Connecting a sourcing output device to an auxiliary input line

Connect a sourcing output device to a Zebra Altiz 4200 auxiliary input line, as shown below.

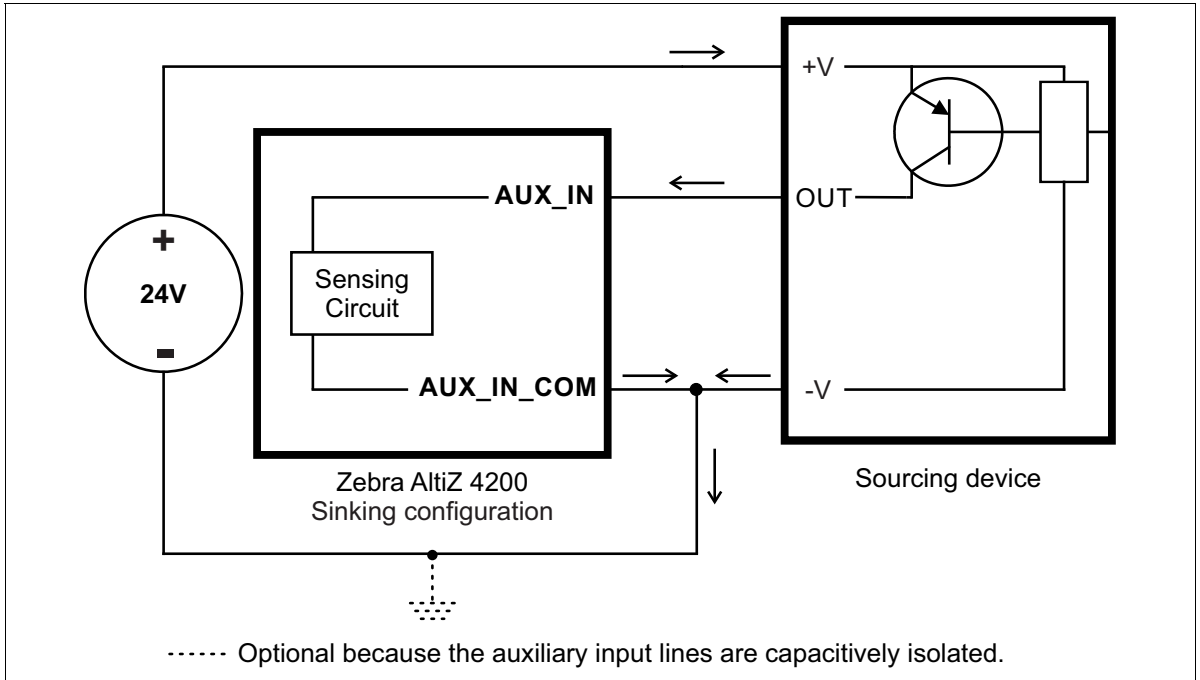

Equivalent circuit only

Connecting a sinking output device to an auxiliary input line

Connect a sinking output device to a Zebra Altiz 4200 auxiliary input line, as shown below.

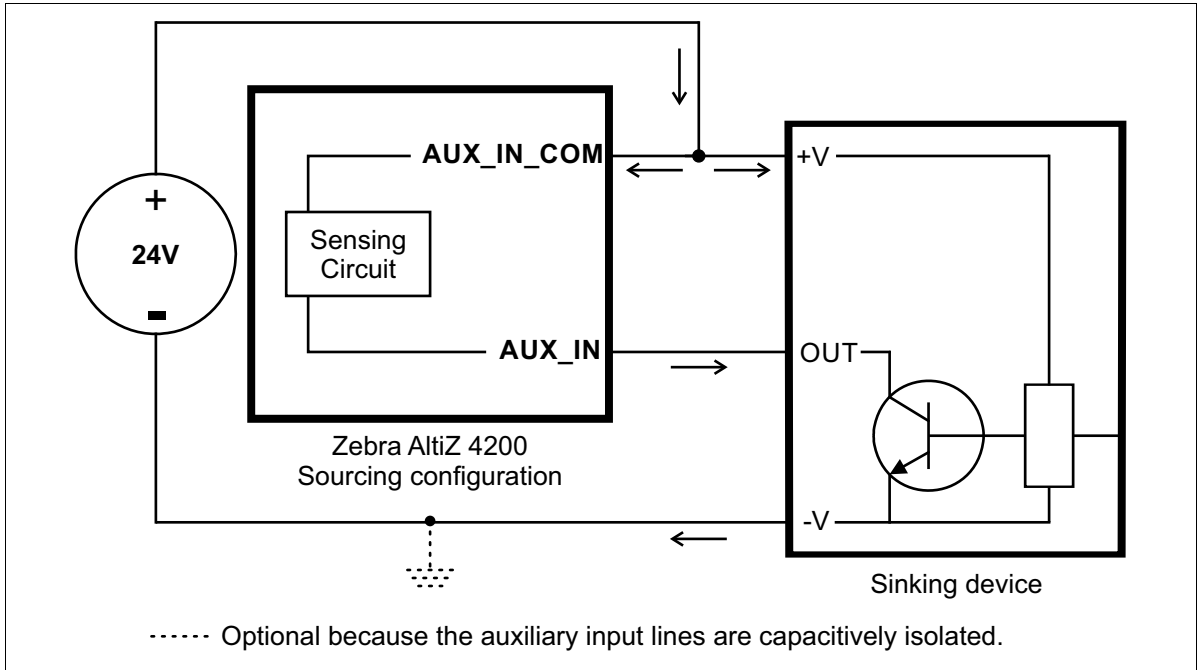

Equivalent circuit only

Connecting a 3-wire PNP proximity sensor to an auxiliary input line

Connect a 3-wire PNP proximity sensor to a Zebra AltiZ 4200 auxiliary input line, as shown below.

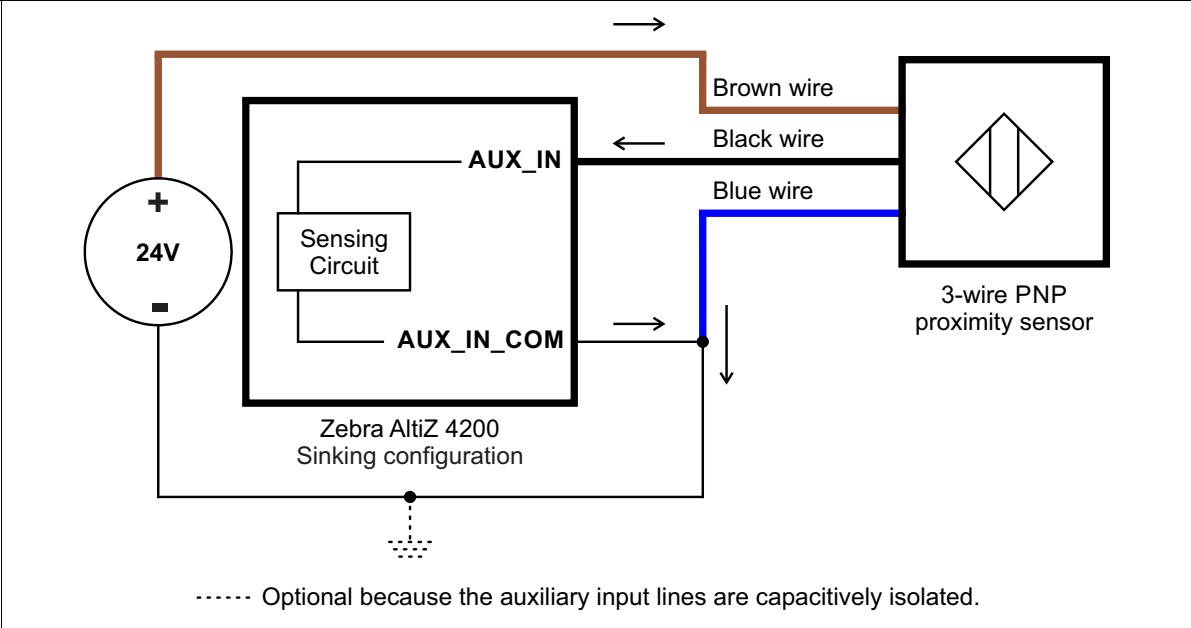

Equivalent circuit only

Connecting a 3-wire NPN proximity sensor to an auxiliary input line

Connect a 3-wire NPN proximity sensor to a Zebra AltiZ 4200 auxiliary input line, as shown below.

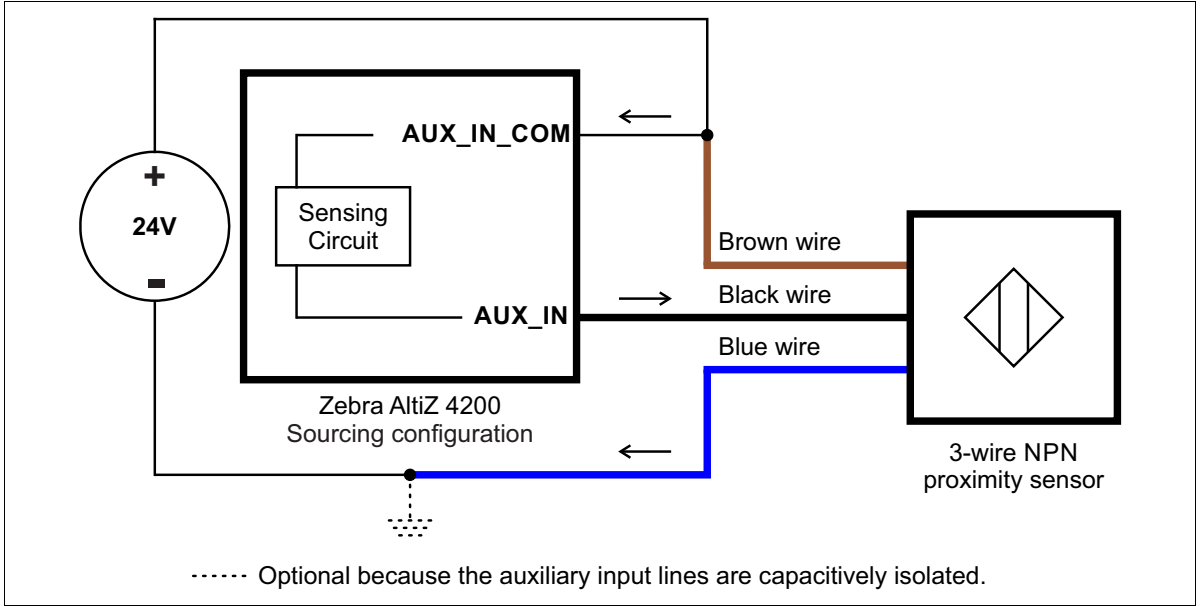

Equivalent circuit only

Connecting a 2-wire proximity sensor to an auxiliary input line

You can connect a 2-wire proximity sensor to a Zebra AltiZ 4200 auxiliary input line in either a sourcing or sinking configuration (that is, on a positive or negative power wire). Note that in both cases, you will need to install an external bleeder resistor, to ensure that a minimum amount of current flows into the proximity sensor in its on-state and in its off-state.

- For the auxiliary input line to source the current (that is, to connect an auxiliary input line on a positive power wire), connect the 2-wire device to the auxiliary input line as shown below. You must also install an external bleeder resistor between the AUX_IN_COM pin and brown wire of the proximity sensor.

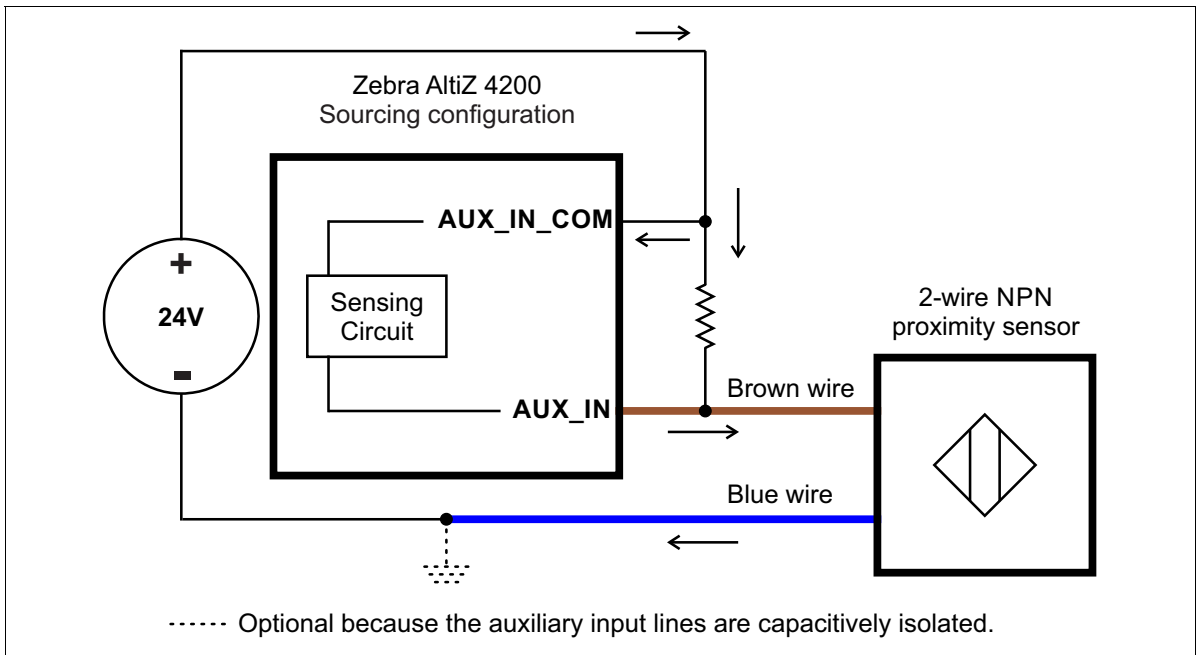

Equivalent circuit only

The bleeder resistor's value should guarantee that the minimal required current is provided to the connected sensor (the third-party device). For details regarding the sensor's minimum current requirements, refer to its documentation. Note that you should use a bleeder resistor with an appropriate power rating for your circuit.

For the auxiliary input line to sink the current, connect the 2-wire device to auxiliary input line as shown below. Install the external bleeder resistor between the blue wire of the proximity sensor and the AUX_IN_COM pin.

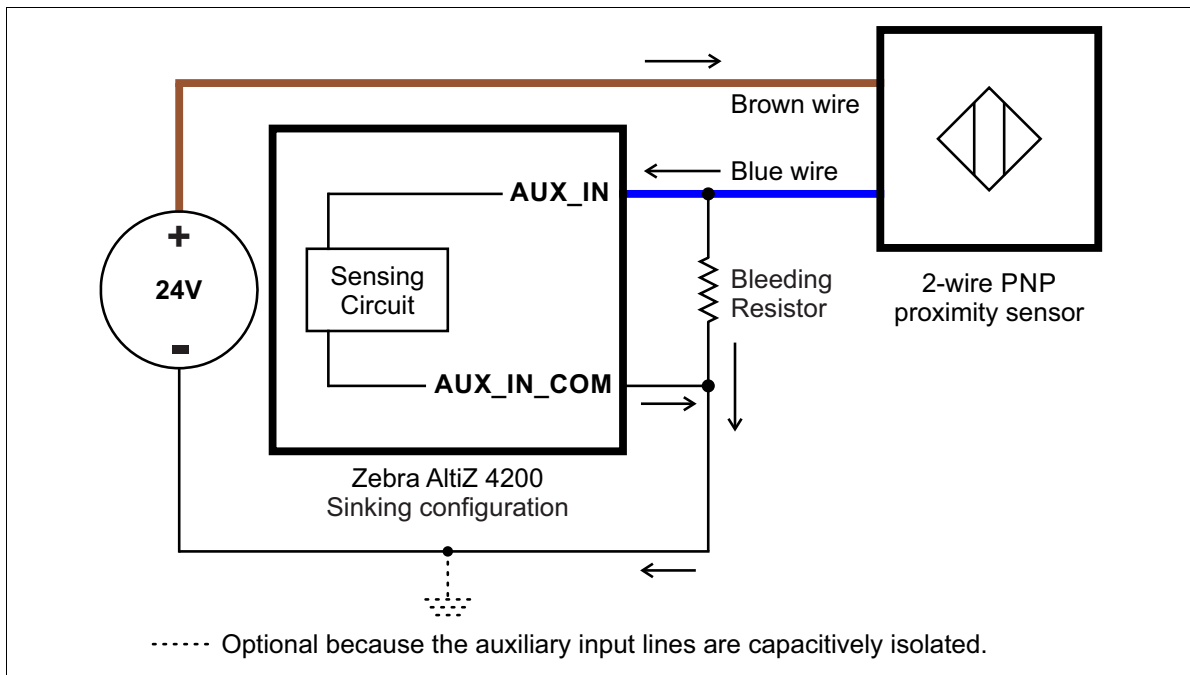

Equivalent circuit only

Connecting multiple auxiliary devices to Zebra AltiZ 4200

You can connect multiple auxiliary devices to Zebra AltiZ 4200 auxiliary lines in either sourcing or sinking configuration. In the following examples, a 3-wire proximity sensor and an encoder are connected. These auxiliary devices can be used as a frame trigger source and a line (profile) trigger source, respectively, as described in *Setting up frame triggers for single-profile scans or multi-profile surface scans* section, in *Chapter 4: Understanding and setting the features of your Zebra AltiZ 4200*.

Note that, in the following examples, Zebra AltiZ 4200 is powered by a standard 24 V power supply; however, this is not required if you are powering Zebra AltiZ 4200 using PoE. Whether you use PoE or a standard 24 V (+/-10%) power supply, ensure that AUX_IN_COM is connected for sinking or sourcing, depending on your configuration.

Connecting multiple sourcing peripheral devices

The following example illustrates connecting multiple sourcing peripheral devices to the auxiliary I/O interface of Zebra Altiz 4200. In this setup, each connected auxiliary line is sinking the current and the pin of the corresponding peripheral device is sourcing the current. That is, the auxiliary input lines of Zebra Altiz 4200 are wired as sinking inputs (AUX_IN_COM=0 V); therefore, they are expecting PNP/sourcing outputs from peripheral devices.

Important

Note that if labeled, the output pin of a connected device is typically labeled with the type of output it is able to provide (whereas, although not illustrated, the input pin of a connected device is typically labeled with the type of signal that it expects to receive). The proximity sensor is labeled PNP because its output pin is sourcing the current. Refer to the documentation of your devices to establish if they follow this convention.

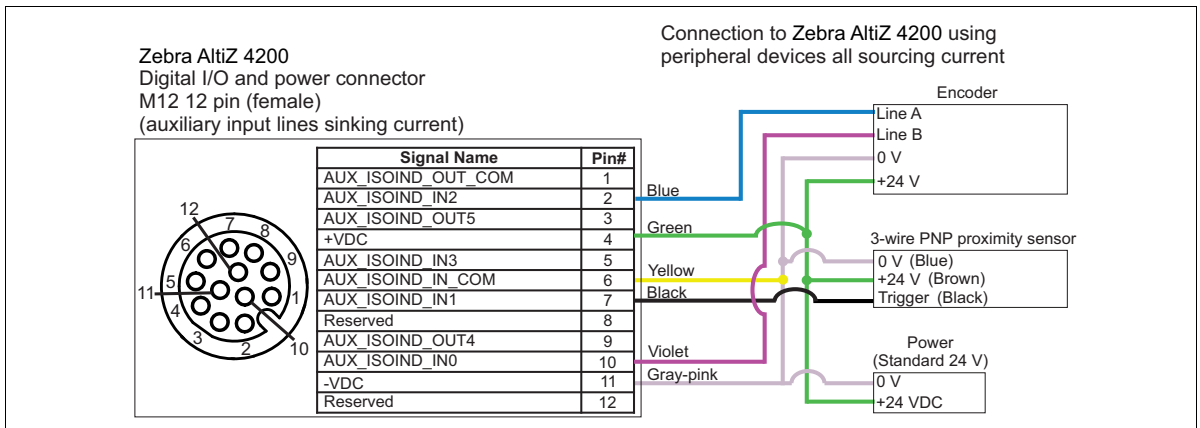

Equivalent circuit only

Connecting to multiple peripheral sinking devices

The following example illustrates connecting multiple sinking peripheral devices to the auxiliary I/O interface of Zebra AltiZ 4200. In this setup, each connected auxiliary line is sourcing the current and the pin of the corresponding peripheral device is sinking the current. That is, the auxiliary input lines of Zebra AltiZ 4200 are wired as sourcing inputs (AUX_IN_COM=24 V); therefore, they are expecting NPN/sinking outputs from peripheral devices.

Important

Note that if labeled, the output pin of a connected device is typically labeled with the type of output it is able to provide (whereas, although not illustrated, the input pin of a connected device is typically labeled with the type of signal that it expects to receive). The proximity sensor is labeled NPN because its output pin is sinking the current. Refer to the documentation of your devices to establish if they follow this convention.

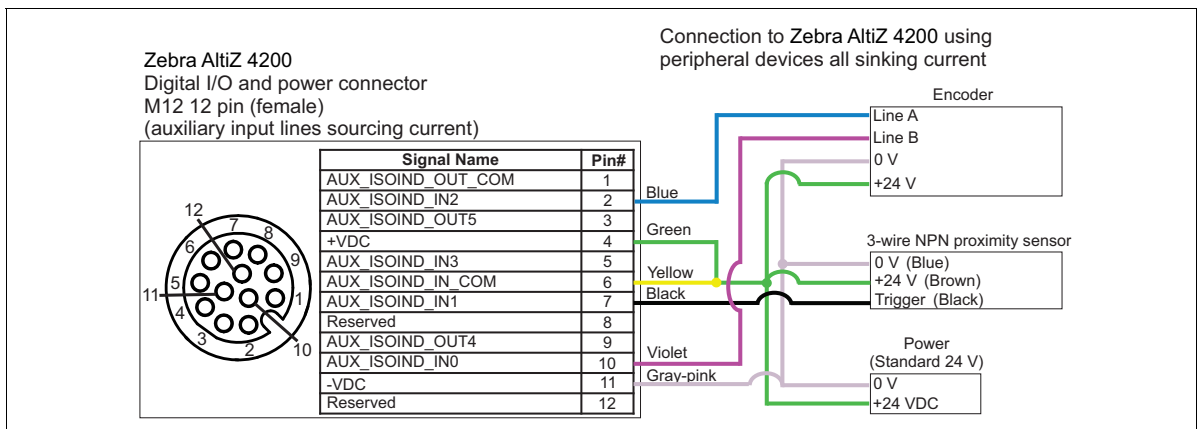

Equivalent circuit only

Chapter

3

Step-by-step Zebra Altiz 4200 configuration with Aurora Imaging Capture Works

This chapter provides an overview on how to configure Zebra Altiz 4200 using Aurora Imaging Capture Works for some common use cases.

Configuring Zebra Altiz 4200 with Aurora Imaging Capture Works

This chapter provides steps on how to configure Zebra Altiz 4200 for some common use cases, using Aurora Imaging Capture Works. When you install your Zebra software (Aurora Imaging Library, Aurora Imaging Library-Lie, or Aurora Imaging Design Assistant), Aurora Imaging Capture Works is automatically installed. Launch Aurora Imaging Capture Works from the **Aurora Imaging Control Center** or by typing "Capture Works" in the **Windows Start** menu. The instructions provided in this chapter should be sufficient to use Aurora Imaging Capture Works with Zebra Altiz 4200. For additional information on how to use the utility, see the Aurora Imaging Capture Works user guide.

The use cases that are covered in this chapter include: how to set up acquisition for a single-profile scan, how to set up acquisition for a multi-profile surface scan using a constant line (profile) rate, and how to set up acquisition for a multi-profile surface scan using an encoder. Zebra Vision Academy also provides videos for some of these use cases. To follow these use cases with videos, visit zebra.com/vision-academy and go to the **Using the Zebra Altiz 4200 series** under the **Hardware** section.

- ❖ Note that the numbers given in these use cases assume you are using Zebra Altiz 4200 AZ2S5SB. Also, the object that was used in scanning is shown below, and the values provided in these use cases are based on the length of this object. The values that you should use for some features will depend on your model of Zebra Altiz 4200 and your scanned object.

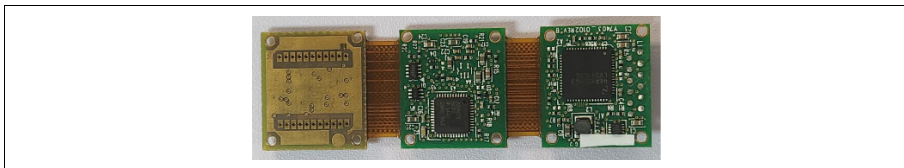

For information on the specific Zebra Altiz 4200 GenICam features used in this chapter, see *Chapter 4: Understanding and setting the features of your Zebra Altiz 4200* and *Chapter 5: Zebra Altiz 4200 GenICam feature reference*.

Case 1: Quickly performing a single-profile scan with default settings

To quickly set up Zebra AltiZ 4200 to perform a single-profile scan using default settings, do the following.

1. Open Aurora Imaging Capture Works and allocate the required Zebra AltiZ 4200 by double-clicking on it in the presented list of available devices or by right-clicking on it and selecting **Alloc**.

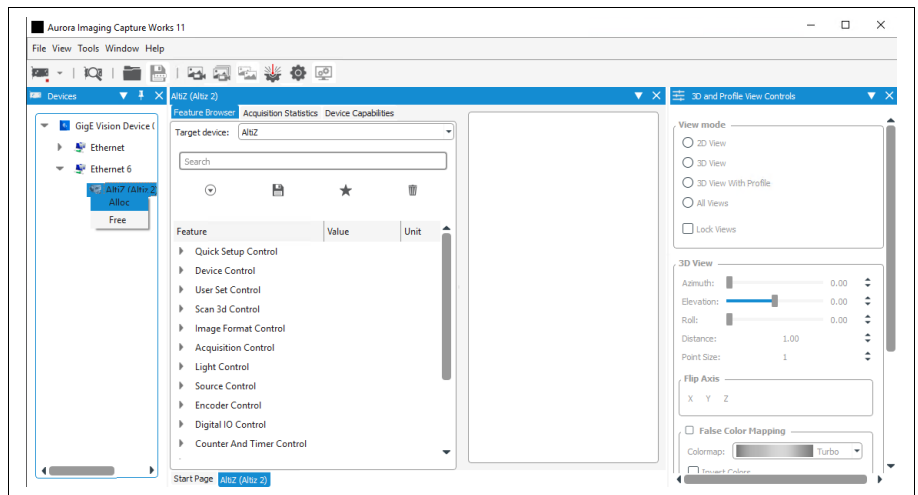

2. After allocating Zebra AltiZ 4200, the Feature Browser will appear with a list of available features. Expand **Quick Setup Control**. You will notice that, by default, Zebra AltiZ 4200 is setup to acquire in **Profile** mode (single-profile scan), which means **Length World** (`Scan3dVolumeLengthWorld`) is set to **0**.

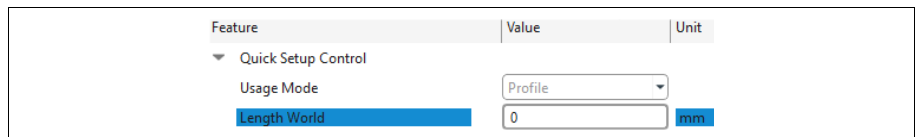

3. Click the **Single Grab** toolbar button () to begin acquisition of a profile.
Optionally, you can select **3D View With Profile** for both a 2D and 3D view of the profile.

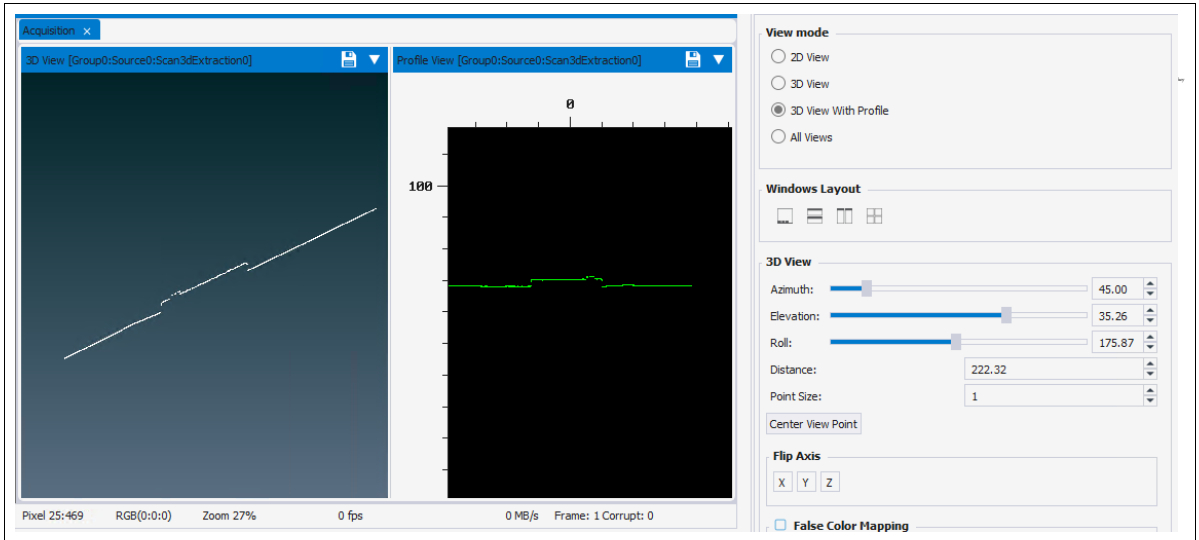

Case 2: Performing a single-profile scan with optimized settings

To set up Zebra AltiZ 4200 to perform a single-profile scan with optimized settings, do the following:

1. Once the required Zebra AltiZ 4200 is allocated, validate the setup. To do so, click on the **Zebra AltiZ 4200 Setup** toolbar button (outlined in red below).

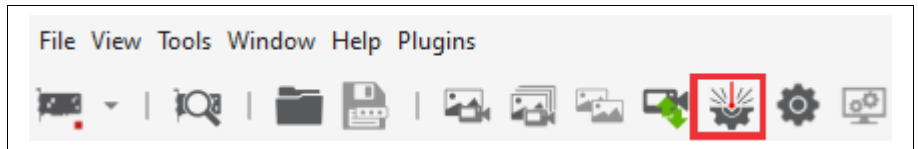

This will open the Zebra AltiZ 4200 Setup window, which presents a list of all the necessary features related to laser intensity, exposure, peak extraction, as well as displays the intensity component from the image sensor (the image of the laser line) and a profile view.

2. If you find that Zebra AltiZ 4200 is not able to acquire an image of the laser line with an appropriate intensity:
 - a. First, be sure that your object is in the field of view.
 - b. Proceed to adjust the laser light to get a thin line with an appropriate contrast, or adjust the exposure so that it is appropriate for your environment. For information on how laser light and exposure relate, see *Laser control and exposure* section, in *Chapter 4: Understanding and setting the features of your Zebra AltiZ 4200*.
3. Use the colors displayed in the **Intensity** window and the **Profile View** window to see information about the extracted peaks. Selected peaks from the image sensor (Source0) are green, and peaks that were not are left blank. If settings are adjusted correctly, the **Profile View** should show mostly green peaks, except for occluded parts of the scanned object.

The default values for peak extraction, along with an appropriate laser brightness and correct exposure time, should provide acceptable 3D data of your scanned object; however, if you find you are not seeing the required peaks, you can change

the peak extraction values under **Peak Extraction Control**. For information on how to set peak extraction features, see *Adjusting peak extraction settings* section, in *Chapter 4: Understanding and setting the features of your Zebra AltiZ 4200*.

- Optionally, reduce and offset the scan area along the Z-axis, to include only the area of interest (for example, the top part of your object) instead of the entire available Z-range; this reduces the grabbed laser line image size and increases the acquisition speed.

In the **Profile View** window, drag the first measurement marker above the profile, so that it is slightly above. Now, drag the second measurement marker below the profile, so that it appears slightly below. In the **Zebra AltiZ 4200 Volume Properties** window, outlined in red below, you will see the numbers used for both **Size Z World** (`Scan3dVolumeSizeZWorld`) and **Offset Z World** (`Scan3dVolumeOffsetZWorld`).

The screenshot displays the Zebra AltiZ 4200 software interface. The main window is divided into several sections:

- Intensity View:** Shows a 3D scan of a rectangular object with a white line representing the laser line.
- Profile View:** Shows a 2D intensity profile of the scan. The vertical axis is labeled with values 110, 120, 130, 140, and 150. The horizontal axis is labeled with values -30, -20, -10, 0, and 10. Two measurement markers are visible: one at Z:128.440 mm and another at Z:132.982 mm. The text "Volume Z" and "4.542 mm" is displayed between the markers.
- Quick Setup Control Panel:** Located on the right, it contains a "Properties" section with the following details:
 - Name: QuickSetupControl
 - Display Name: Quick Setup Control
 - Interface Type: Category
 - Visibility: Beginner
 - Access Mode: Read Only
- Volume Properties Panel:** Located at the bottom right, outlined in red, it displays the following values:
 - Volume Z World
 - Offset Z World: 128.440 mm
 - Size Z World: 4.542 mm

At the bottom of the interface, there is a status bar with the following information: "1d, 8-bit unsigned Pixel: -176:532 Zoom: 12% Acquisition: 10 Hz Display: 1 Hz 95 MB/s Frame: 328 Corrupt: 312".

- Once your values are set in the **Zebra AltiZ 4200 Setup** window, click on the check mark (||); the corresponding Zebra AltiZ 4200 features will be updated with these values.

6. At this point, you should save your feature settings to a user set so that you can reload them when needed. Use the features in the **User Set Control** sub-category of the **Quick Setup Control** category. Choose in which writable user set to save your settings (UserSet0, UserSet1, UserSet2, or UserSet3) and then click **User Set Save**. For the purpose of the remaining examples in this chapter, save them to **UserSet0**; also, change the default user set to load when Zebra AltiZ 4200 is reset, to **UserSet0**. It is a good idea to enter a description for your user set under **User Set Description** before saving.
7. Click the **Single Grab** toolbar button () to begin acquisition of a profile.

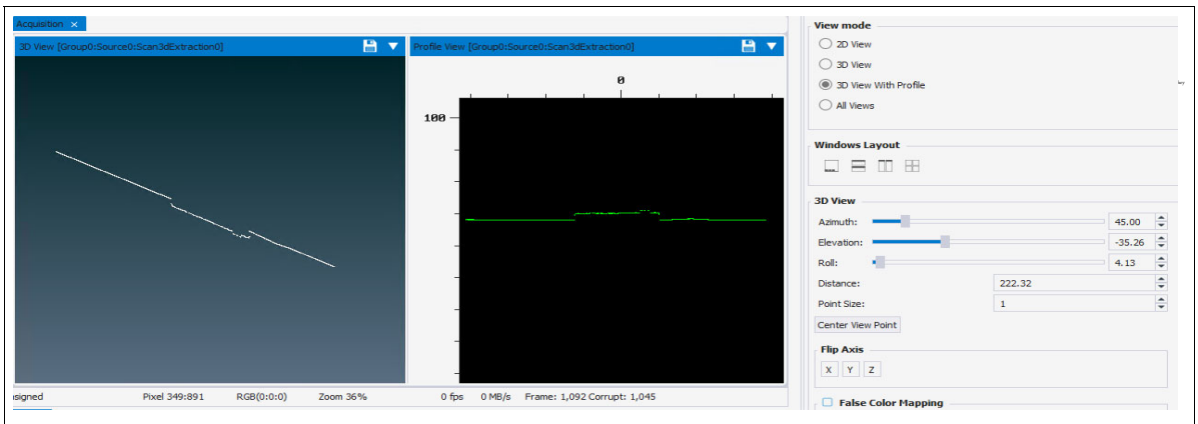

8. Optionally, flip the Z-axis in the 3D View window. In **Profile** mode, by default, **Coordinate System Anchor Mode** (`Scan3dCoordinateSystemAnchorMode`) is set to **Reference**, where the Z-axis points from Zebra AltiZ 4200 to the object. If you need to see the scan in the 3D view right side up, select **Flip Axis Z**. This is only available when **3D View With Profile** is selected.
- ❖ Note that this is only a display effect. To take measurements from the bottom of the object, set **Coordinate System Anchor Mode** to **Height**, before adjusting the scan offset. In **Height** mode, the Anchor coordinate system is positioned at the far field of view (FOV) with the Z-axis pointing towards Zebra AltiZ 4200.

Case 3: Performing a multi-profile surface scan using a constant line (profile) rate

Once you have performed a single-profile scan (Case 1) and seen how to make optimizations if required (Case 2), you are ready to perform a multi-profile surface scan, using a constant line (profile) rate. To do so:

1. Under the **Quick Setup Control** category, change **Length World** (`Scan3dVolumeLengthWorld`) to the length of your object. For this example, the object has a length of 70 mm, but to give some extra space for when the scan begins and ends, **Length World** (`Scan3dVolumeLengthWorld`) has been set to 85 mm. Notice that when this feature is set to a non-zero value, **Usage Mode** (`Scan3dUsageMode`) changes to **Surface**. Other features related to surface scanning will also become visible.

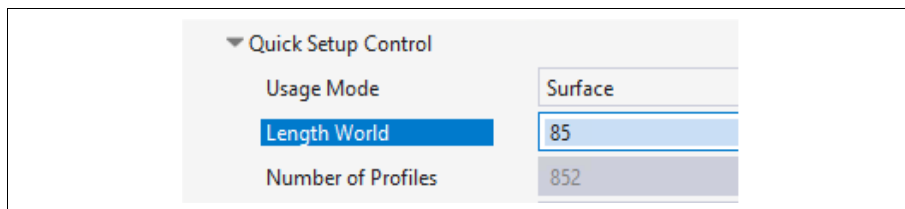

2. For this example, set **Coordinate System Anchor Mode** to **Height** so that measurements are taken from the bottom of the object. Note that if you have set a custom scan area, it is automatically adjusted so that it encompasses the same area but relative to the new position. For information on the Anchor coordinate system modes, see *Anchor coordinate system modes* section, in *Chapter 4: Understanding and setting the features of your Zebra Altiz 4200*.
3. Now, set whether the speed of motion or the displacement (step) between each consecutive profile is a fixed requirement, using **Motion Input Type** (`Scan3dMotionInputType`). When you set one as a fixed requirement, the other is automatically¹ set to attain the maximum acquisition line (profile) rate (`AcquisitionLineRateMax`). For this example, set **Motion Input Type** (`Scan3dMotionInputType`) to **Speed** and set **Motion Speed World** (`Scan3dMotionSpeedWorld`) to the speed of your conveyor (for example, 25 mm/sec). If the motion does not match this speed, you will acquire the object at the wrong aspect ratio. The relationship between speed, scan displacement, and

1. As long as `AcquisitionLineRateEnable` is set to `False`.

acquisition line rate is described in the *Specifying scan step when using a constant line (profile) rate* section, in *Chapter 4: Understanding and setting the features of your Zebra Altiz 4200*.

- Click on the **Single Grab** toolbar button () to perform a multi-profile surface scan, assuming the part is moving. A progress bar appears at the bottom right of the Aurora Imaging Capture Works window while Zebra Altiz 4200 is performing the scan. For better visibility, change the color mapping to **Turbo**. The resulting surface will appear in the 3D view.

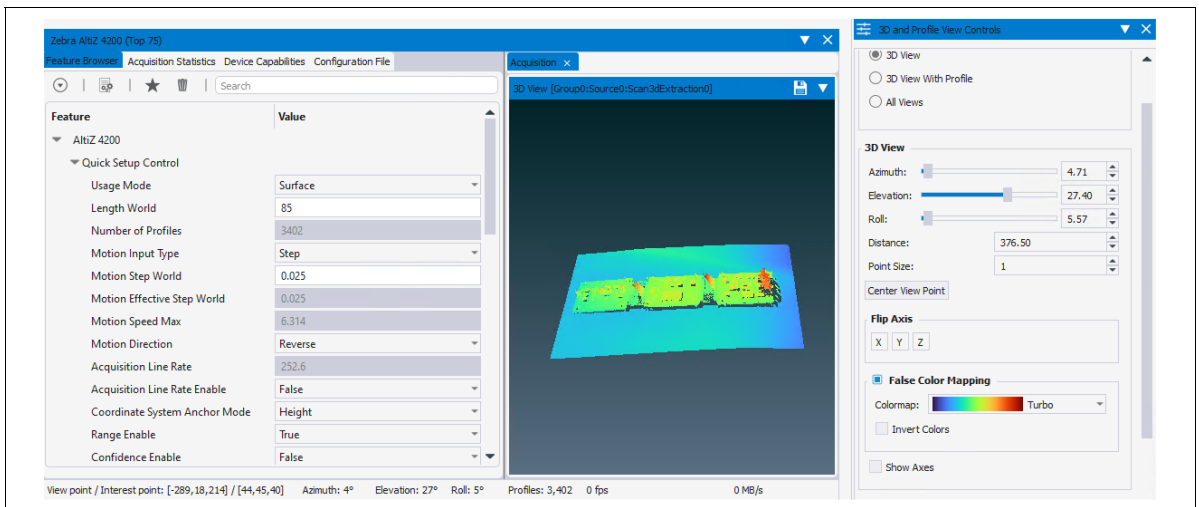

Case 4: Performing a multi-profile surface scan using an encoder

Once you have performed a multi-profile surface scan at a constant line rate, and seen how to perform optimizations if required (Case 3), you are ready to setup your Zebra Altiz 4200 to scan using an encoder as a line (profile) trigger. First, you will need to wire the encoder to your Zebra Altiz 4200. Below is an example of how to wire an encoder that is sinking, while powering Zebra Altiz 4200 over PoE+ (PSE 50-57 Vdc):

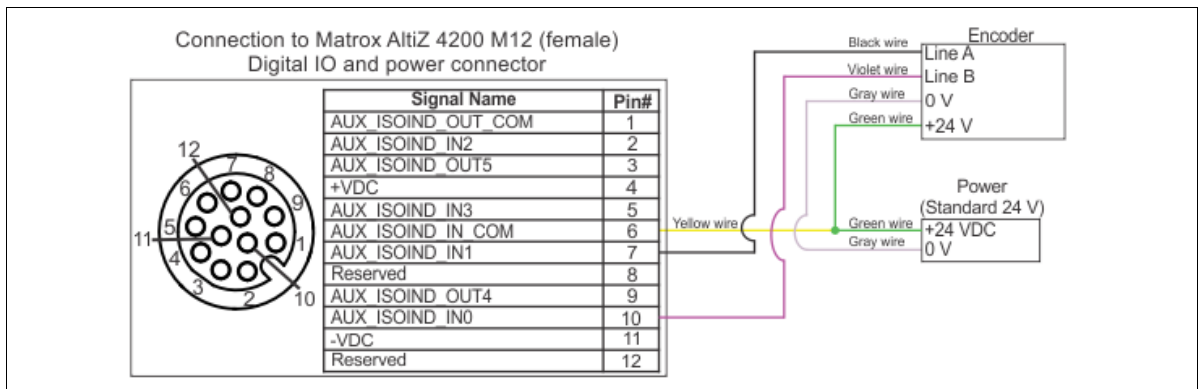

Once the encoder is wired appropriately, you can begin to configure Zebra Altiz 4200 using Aurora Imaging Capture Works. To do so, perform the following:

1. Follow the same steps to set the length of the object and change the Anchor coordinate system mode, as outlined in steps 1 and 2 of the *Case 3: Performing a multi-profile surface scan using a constant line (profile) rate* section earlier in this chapter.
2. Set line (profile) acquisition to be in triggered mode and set its trigger source to be the encoder interface. To do so, navigate to **Trigger Control** under **Quick Setup Control**, and set **Trigger Selector (TriggerSelector)** to **LineStart**. Expand **Trigger Selector** and set **Trigger Source (TriggerSource)** to **Encoder0** and set **Trigger Mode (TriggerMode)** to **On**.
3. To set up the encoder interface, expand **Encoder Control**, and set **Encoder Resolution (EncoderResolution)** to the resolution of your particular encoder. In this example, the encoder resolution is set to 0.0025 mm/ encoder step. Now set **Encoder Source A (EncoderSourceA)** and **Encoder Source B (EncoderSourceB)**

to the auxiliary lines on which to receive bit A and bit B of the 2-bit Gray code. If using the example wiring outlined at the beginning of this example, set them to **Line0** and **Line1**, respectively.

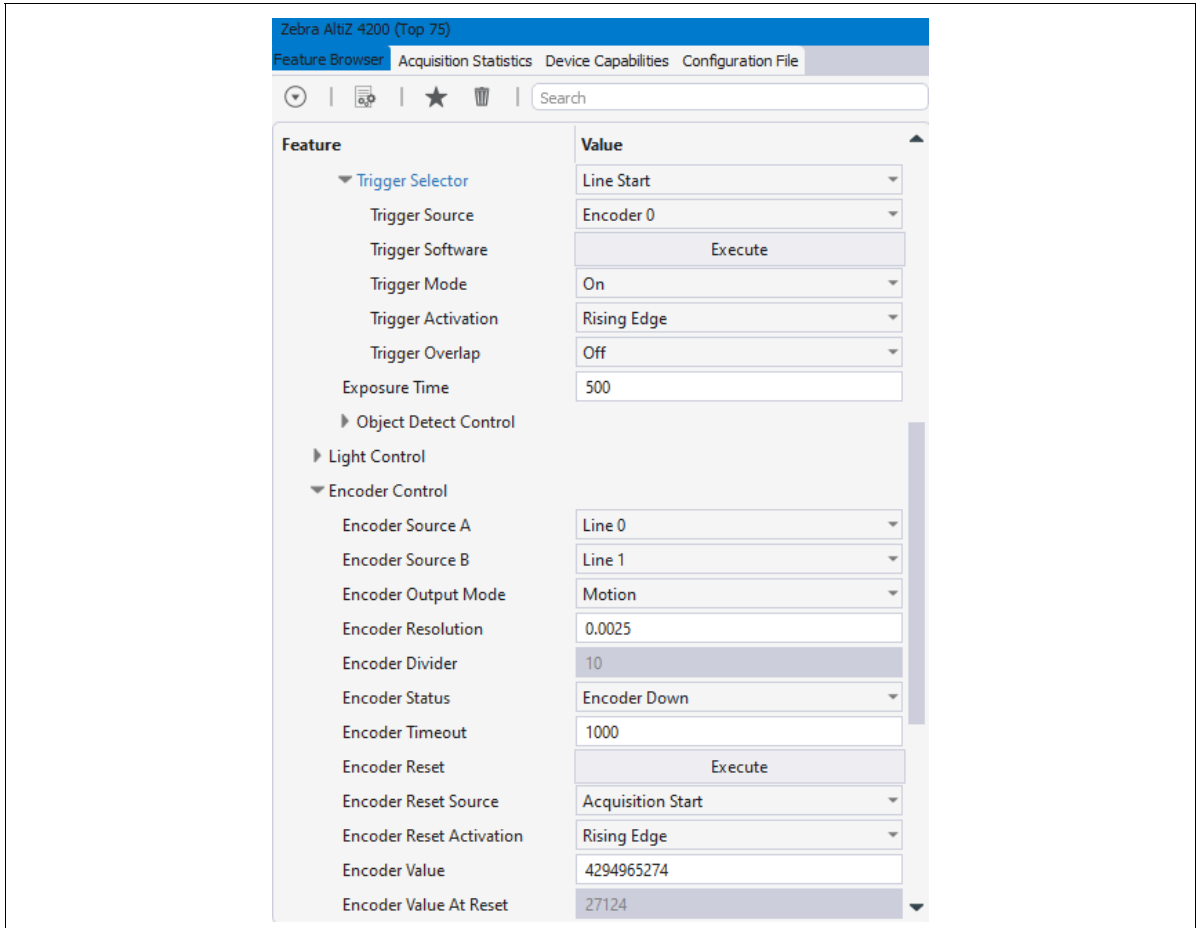

- For this example, you will be explicitly specifying the required displacement between consecutive profiles, so navigate to **Quick Setup Control** and set **Motion Input Type (Scan3dMotionInputType)** to **Step**.

Aurora Imaging Capture Works automatically calculates the required encoder divider and maximum motion speed when you provide the scan step and the encoder resolution. For this example, set **Motion Step World (Scan3dMotionStepWorld)** to 0.025 mm/line (profile) trigger (that is, acquire a profile every 0.025 mm along the direction of motion). When you do this, the

Motion Effective Step World (`Scan3dMotionEffectiveStepWorld`) is also generated and will be the closest possible match to the **Motion Step World**. The discrepancy between **Motion Step World** and **Motion Effective Step World** is a result of the encoder resolution. You will notice that **Motion Speed Max** (`Scan3dMotionSpeedMaxWorld`) also changes. In this example, **Motion Speed Max** is 6.314 mm/s. Ensure that your conveyor speed does not exceed the provided maximum speed; otherwise, you will miss the line (profile) trigger.

5. Click on the **Single Grab** toolbar button () to perform a scan of the surface. You must also activate the conveyor so that the object begins to move. The resulting surface will appear in the 3D view.

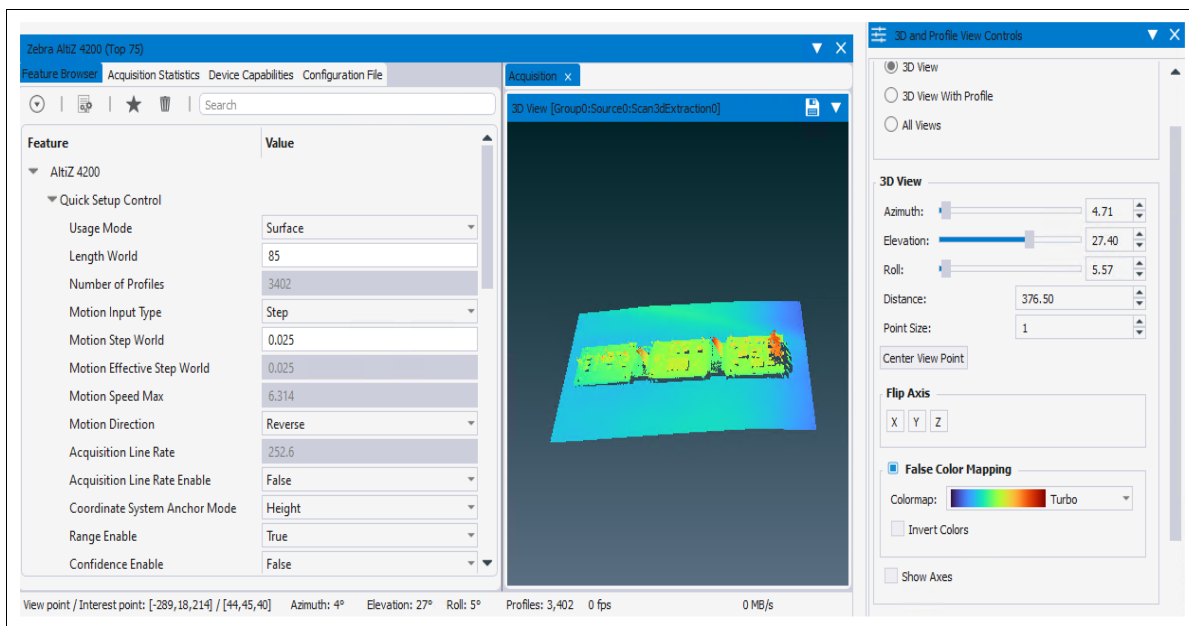

Chapter

4

Understanding and setting the features of your Zebra Altiz 4200

This chapter describes how Zebra Altiz 4200 acquires 3D data and how to control this process using Zebra Altiz 4200's GenICam features.

Steps to performing basic 3D scans with Zebra AltiZ 4200

The following is a basic methodology for using Zebra AltiZ 4200 to capture both single-profile scans and multi-profile surface scans.

1. Mount and connect your Zebra AltiZ 4200 appropriately, as outlined in the *Zebra AltiZ 4200 mounting* section, in *Chapter 2: Powering and connecting to your Zebra AltiZ 4200*.
2. Assign a position for the Anchor Coordinate system, as outlined in the *Anchor coordinate system modes* section.
3. Perform a single-profile scan (for example, using Aurora Imaging Capture Works) to validate the setup. Typically, this will result in the expected profile. However, if you are having issues detecting the laser line, try the following in this order:
 - a. If no peaks are detected, the object could be outside the available range (either too far from Zebra AltiZ 4200 or too close to Zebra AltiZ 4200). Adjust Zebra AltiZ 4200 so that the object is found within the available range, as outlined in *Zebra AltiZ 4200 mounting* section, in *Chapter 2: Powering and connecting to your Zebra AltiZ 4200*.
 - b. Adjust the values for laser intensity and exposure time, as outlined in the *Laser control and exposure* section
 - c. Adjust the values for peak extraction and peak selection, as outlined in the *Peak processing* section.
4. Optionally, modify the scan area, and the scan length and step along the direction of motion, to the required region of interest for your scanned object, as outlined in the *Modifying scan area, scan length, and scan step* section later in this chapter. By default, a full-height, single-profile scan will be performed (that is, a profile that can have all possible heights in the available Z-range).
5. Optionally, change how your Zebra AltiZ 4200 outputs data, as outlined in the *Outputting a point cloud or depth map* section. By default, Zebra AltiZ 4200 outputs data in depth map format.
6. Start runtime scanning.

Once you have adjusted your settings appropriately, you can save them to a writable user set: `UserSet0`, `UserSet1`, `UserSet2`, or `UserSet3`. To save a user set, execute `UserSetSave`, and to load a user set, execute `UserSetLoad`. By default, the non-writable **Profile** user set is loaded upon rebooting; you can change the user set loaded by default using `UserSetDefault`. For information on the user sets available for Zebra Altiz 4200, see the *Zebra Altiz 4200 workflow* section later in this chapter.

Quick setup

Zebra Altiz 4200 includes a feature category called `QuickSetup`. It is a category that groups together all required features to perform a scan using Zebra Altiz 4200. It is meant to facilitate performing a scan when using an interface such as Aurora Imaging Capture Works, so that typically required features are easily accessible and found. Some of these features are the exact same features as those found in other categories (for example, `AcquisitionLineRate` and `TriggerSelector`). Other features, prefixed with `QuickSetup`, are quick setup versions of features without the prefix found in other categories. Changing features in either location updates them in both locations. Note that the list of features that appear in the `QuickSetup` category changes dynamically, so that only those features related to your current settings are available.

This chapter refers to all features by their regular (standard setup) names and not their quick setup names. For a full list of the features available on Zebra Altiz 4200, see *Chapter 5: Zebra Altiz 4200 GenICam feature reference*.

Using the Zebra AltiZ 4200 GenICam features

Your Zebra AltiZ 4200 supports the GenICam GenDC specification with 3D data sets and provides both custom and standard GenICam features. To learn more about the standard features available, refer to the GenICam Standard Feature Naming Convention, available on the GenICam website at: <https://www.emva.org/standards-technology/genicam/>.

Zebra AltiZ 4200 provides GenICam features (both standard and custom) that allow you to control the following:

- **Coordinate system position.** Select from multiple pre-set coordinate system modes to easily change the origin and orientation of the coordinate system in which, by default, your results are returned (Anchor coordinate system).
- **Scan area and volume.** Set features to modify your scan area, in world units. This assists in increasing your scanning speed or resolution, among other benefits.
- **On-device filtering.** Set features to select the best peak position.
- **3D data output.** Set features to select whether to output a multi-profile surface scan or a single-profile scan, in either depth map or point cloud format.
- **On-device scan step or motion speed calculation.** Set features to specify whether the scan step (displacement) or the motion speed is provided. If the scan step is provided, then the required motion speed will be calculated by Zebra AltiZ 4200; if motion speed is provided, then scan step (displacement) will be calculated by Zebra AltiZ 4200.

Understanding how 3D depths and coordinates are established

Zebra AltiZ 4200 uses camera-laser triangulation (line profiling) to acquire 3D data. It projects a sheet of light (laser plane) on an object and grabs an image of the laser line on the object from the image sensor. The incidence of the laser light on the object, taken at the angle of the image sensor, leads to an image whereby the line of the laser light is deformed. From the position of the displaced laser line and the known angle of the image sensor to the laser plane, Zebra AltiZ 4200 can obtain depth information for that slice of the object's surface (that is, the profile of the surface along that slice).

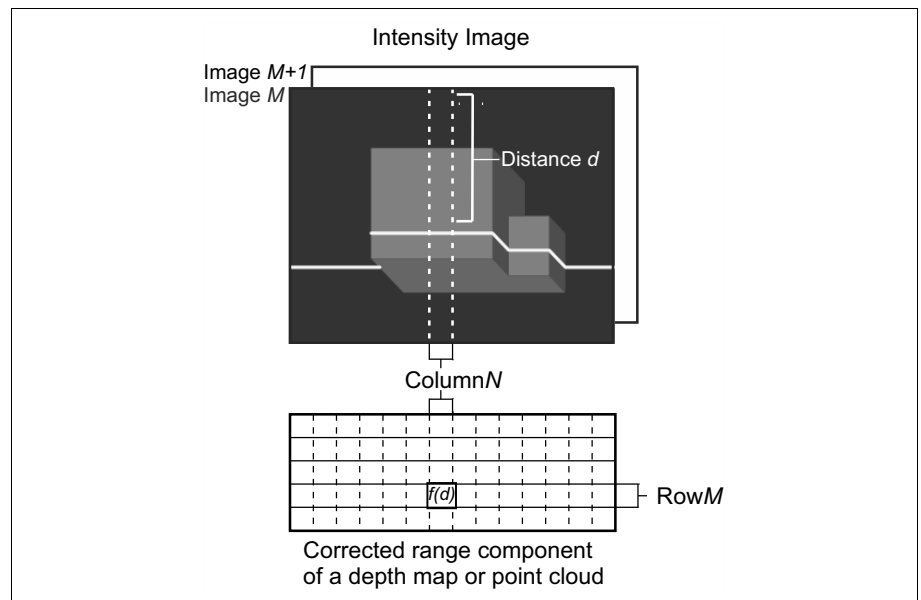

By grabbing a sequence of images as an object moves underneath the laser plane, and repeating the above-mentioned process, Zebra AltiZ 4200 can generate a depth map or point cloud of the exposed topography of the object.

The image sensor's laser line image passes through a laser line extraction process. This process scans each of the image's columns to find the position of the highest intensities (peaks) that meet the specified characteristics of the laser line (for example, local contrast and width (thickness)).

The extracted peak in each column is selected for conversion to a real world depth or XYZ-coordinates (f(d)), depending on the selected output mode **Scan3dOutputMode**. If the image sensor cannot see the laser line in a specific column (for example, because of occlusion), the depth at that specific point is set to the invalid data value (by default, 0).

A single laser line corresponds to a single row of resulting peaks. From these peaks, Zebra AltiZ 4200 establishes the real world depths or XYZ-coordinates of the object's surface along that slice, and stores them consecutively in a row of the range component. If transmitting a single row, this is referred to as a single-profile scan. If grabbing and processing a sequence of laser line images, Zebra AltiZ 4200 outputs one row for every laser line image; this is referred to as a multi-profile surface scan.

If the range component stores real world depths (**RectifiedC**), the transmitted scan is referred to as a depth map; if the range component explicitly stores the XYZ-coordinates (**CalibratedABC_Grid**), the transmitted scan is referred to as a point cloud. In a depth map, the X and Y-coordinates are inferred from the grid of the range component; the range component only stores the Z-coordinates, as 16-bit unsigned integers, and an established Z-scale. Whereas, a point cloud explicitly stores world XYZ-coordinates as three 32-bit floating point coordinates. Note that the XYZ-coordinates are relative to the selected Anchor coordinate system position, by default.

Anchor coordinate system modes

By default, Zebra AltiZ 4200 returns coordinates relative to the Anchor coordinate system. The Anchor coordinate system is a Cartesian coordinate system with its position and orientation set according to the selected Anchor coordinate system mode, set with `Scan3dCoordinateSystemAnchorMode`¹. There are three available modes: **ReferencePoint**, **Distance**, or **Height**. Be aware that most GenICam features that you set for Zebra AltiZ 4200 are also relative to the Anchor coordinate system, unless specified otherwise. When a feature is relative to the Anchor coordinate system (for example, `Scan3dVolumeSizeZWorld` or `Scan3dVolumeOffsetZWorld`) that feature value will be updated whenever the Anchor coordinate system mode changes. The available modes are:

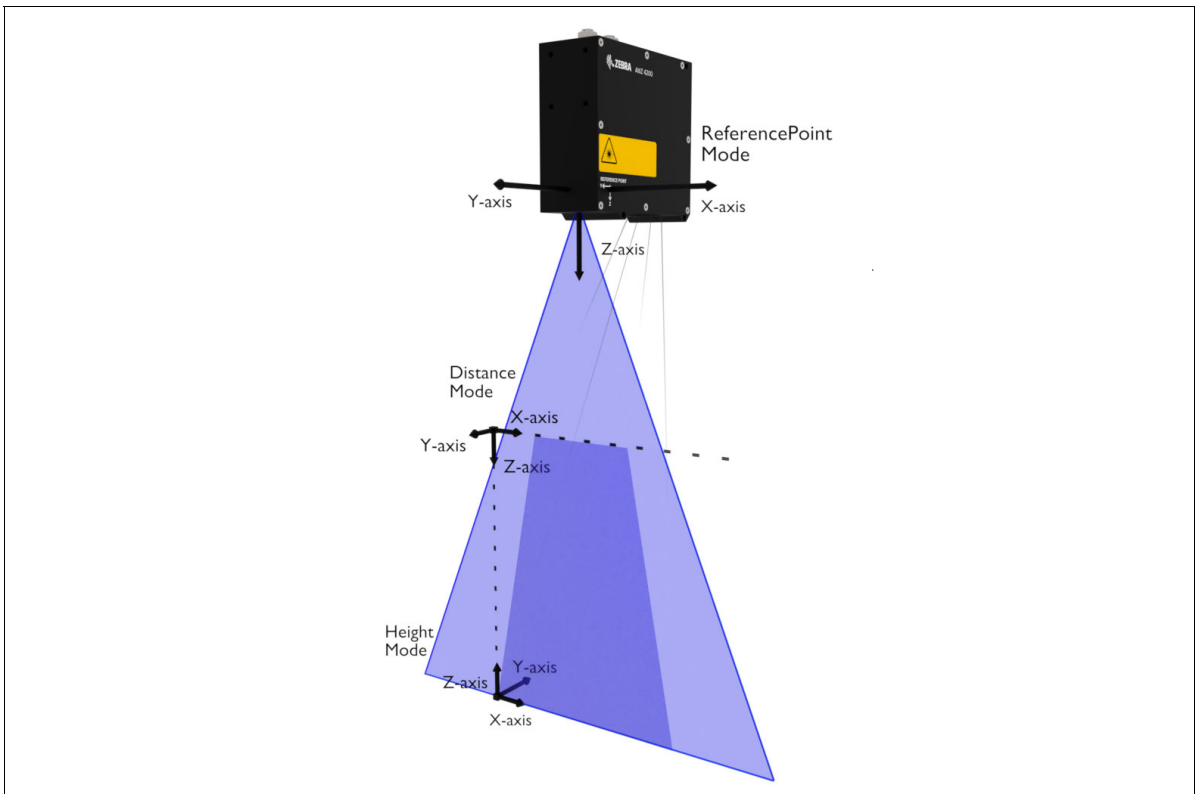

1. The features mentioned in this section have both regular and quick access names. This section refers to them by their regular names. See the *Quick setup* subsection of the *Steps to performing basic 3D scans with Zebra AltiZ 4200* section earlier in this chapter.

Choosing to use one Anchor coordinate system mode over another will depend on your particular setup and the results you are trying to achieve. Each of these modes provide you with easy setup for specific use cases.

- **ReferencePoint mode.** Sets the origin of the Anchor coordinate system to the approximate location identified by the Y-Z reference point mark on the body of Zebra AltiZ 4200, with the X-coordinate centered along the width. The orientation matches the Y-Z reference point mark. In this mode, X-coordinates can be positive or negative, and all Z-coordinates are positive. The **ReferencePoint** mode is useful for setup when you need to find the distance relative to the device itself (for example, when Zebra AltiZ 4200 is attached to a robotic arm).
- **Distance mode.** Sets the origin of the Anchor coordinate system so that, when facing the connectors of Zebra AltiZ 4200, the origin is at the near FoV aligned with the left edge of the far FoV. In this mode, the orientation matches the Y-Z reference point mark found on the Zebra AltiZ 4200 body. All X and Z-coordinates are positive. The **Distance** mode is useful in cases where you want to use Zebra AltiZ 4200 for range finding tasks. With the origin at the near FoV, it is simple to know the distance of the object from the start of the available range without needing to account for the space above the available range (clearance distance).
- **Height mode.** Sets the origin of the Anchor coordinate system so that, when facing the connectors of Zebra AltiZ 4200, the origin of the Anchor coordinate system is to the left edge of the far FoV, and at the beginning of the far FoV. In this mode, the orientation of the Z-axis points towards the body of Zebra AltiZ 4200, with the Y-axis pointing in the opposite direction from the Y-Z reference point mark. All X and Z-coordinates are positive. The **Height** mode provides you with elevation measurements. This is especially useful for scanning objects on a conveyor. Note that Z will typically not equal 0 on the conveyor.

Laser control and exposure

To control the state of the laser, use **LightLaserMode**. It can be set to **Automatic**, **Off**, or **On**. **Automatic** enables the laser to emit light only during the exposure time of an acquisition; by default, the laser is set to **Automatic**. **Off** is a software control to ensure the laser does not emit light. **On** enables the laser to emit continuously at a fixed intensity, which overrides the set laser intensity. This is useful only when you need to simply see the laser for adjusting purposes. If **On** is enabled and a grab initiates, the laser will switch to **Automatic**.

Laser brightness should be adjusted before updating any extraction or exposure settings, because an appropriate laser brightness can generate useful peaks without the need to make other adjustments. If the laser brightness is set to maximum, you will see more reflectance and scatter, which can lead to an over-saturated and less accurate laser line. Conversely, if the laser brightness is set too low, you will not be able to distinguish the laser line from the other intensities in the laser line image. To adjust laser brightness, set **LightLaserBrightness** to an integer value representing the percentage of total laser strength.

If adjusting the laser brightness does not produce an acceptable outcome, adjust the exposure time. Note that the laser brightness relates to how you should set your exposure time. A brighter laser will allow for a shorter exposure time, increasing maximum possible acquisition line (profile) rate; however, if the laser is too bright, you risk oversaturating your laser line. If the laser line is too dim, you might need to increase the exposure time, which leads to motion blur. To control exposure time, set **ExposureTime** to the appropriate value in μs .

Note that if after adjusting the laser brightness and exposure you are still having issues, see the *Peak processing* section.

Modifying scan area, scan length, and scan step

After performing a single-profile scan to validate the setup, you might want to set a scan area, and a scan length and scan step (displacement) along the direction of motion. By default, a full-height, single-profile scan will be performed (that is, a profile that can have all possible heights in the available Z-range).

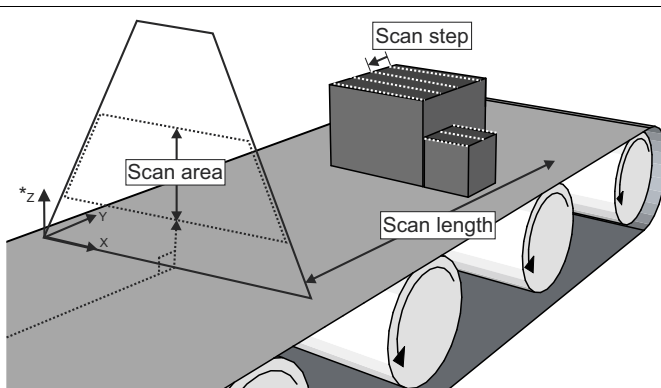

* Location of anchor coordinate system and offset are dependent on the selected mode.

Scan area

Setting a scan area smaller than the entire size of the available range reduces the grabbed laser line image size. This increases the maximum possible acquisition line rate (rate at which profiles are taken); this is useful if you need to increase scan speed or resolution. Ideally, the scan area should only correspond to your area of interest (for example, only the top part of your object).

To control the scan area along the Z-axis, set **Scan3dVolumeZMode** to **Configurable**. Then, use **Scan3dVolumeSizeZWorld**¹ to specify a required size along the Z-axis in mm (world units); use **Scan3dVolumeOffsetZWorld** to specify the offset of this size from Z=0, in the Anchor coordinate system.

The size along the X-axis is always set to the maximum X of your model type; see the *Models available* section, in *Chapter 1: Before you begin* for information.

1. The features mentioned in this section have both regular and quick access names. This section refers to them by their regular names. For more information, see the *Quick setup* subsection of the *Steps to performing basic 3D scans with Zebra AltiZ 4200* section earlier in this chapter.

Scan length and scan step (displacement)

To output a multi-profile surface scan, you must specify the required scan length along the direction of motion, and either directly or indirectly the scan step (displacement) between each consecutive profile. Using this information, Zebra AltiZ 4200 will calculate the number of consecutive profiles it must take to scan the required scan length.

Scan length

To specify the scan length, set **Scan3dVolumeLengthWorld** to a value in mm (world units). By default, **Scan3dVolumeLengthWorld** is set to **0**, which will output a single-profile scan. Note that you should include the distance from the start of the scan trigger (frame trigger) until the end of the object.

Scan step (displacement)

To specify the scan step, you need to consider whether the line (profile) rate will be constant, or if it will be variable and established by a trigger. In both cases, the displacement between profiles must be constant. For information on how to specify displacement when not using a line (profile) trigger, see the *Specifying scan step when using a constant line (profile) rate* section. For information on how to specify the displacement when using a line (profile) trigger, see the *Specifying displacement when using a line (profile) trigger* section.

The Zebra Vision Academy online training resource is available to help you visualize setting the scan step for Zebra AltiZ 4200. For access to these videos, visit zebra.com/vision-academy.

Positive versus negative displacement

If the object is moving in the same direction as the Y-axis of the Anchor coordinate system, set **Scan3dMotionDirection** to **Same**; if the object is moving in the opposite direction from the Y-axis, set **Scan3dMotionDirection** to **Reverse**. Otherwise, your data will be a mirrored representation of your scanned object. Keep in mind that the selected Anchor coordinate system mode affects the direction of the Y-axis.

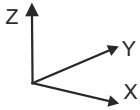
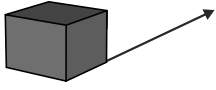
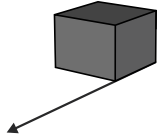
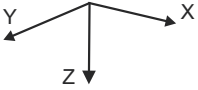
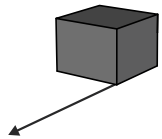
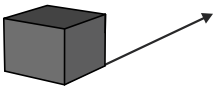
Anchor coordinate system	Scan3dMotionDirection: Same	Scan3dMotionDirection: Reversed
<p>Height Mode</p> 		
<p>ReferencePoint Mode and Distance Mode</p> 		

Specifying scan step when using a constant line (profile) rate

To scan an object at a constant line (profile) rate (that is, without triggers), you need to specify either the scan step (displacement) or motion speed; the other will be calculated automatically. To specify which you will provide, set **Scan3dMotionInputType** to either **Step** or **Speed**, respectively.

- Scan step (**Scan3dMotionStepWorld**) in mm/line (profile).
- Motion speed (**ScanMotionSpeedWorld**) in mm/sec.

If you need to scan the object at a specific resolution, specify the scan step; the required speed of movement will be returned. If using an existing conveyor belt that runs at a specific speed, specify motion speed; the scan step will be calculated automatically.

Zebra AltiZ 4200 uses the acquisition line (profile) rate (**AcquisitionLineRate**) to calculate the missing information; this rate corresponds to the number of acquired profiles per second (lines/sec). By default, Zebra AltiZ 4200 sets **AcquisitionLineRate** to the maximum acquisition line (profile) rate (**AcquisitionLineRateMax**) so that you achieve maximum accuracy (scan resolution). If you need to set the acquisition line rate manually, set **AcquisitionLineRateEnable** to **True** and specify a value for **AcquisitionLineRate** in lines/sec. Note that the maximum acquisition line (profile) rate increases as either the scan area decreases (discussed earlier in this section), or as exposure time decreases (discussed in the *Laser control and exposure* section earlier in this chapter).

The acquisition line (profile) rate, the scan step, and the motion speed have the following relationship:

$$\text{Scan3dMotionStepWorld}(mm/line) = \frac{\text{Scan3dMotionSpeedWorld}(mm/sec)}{\text{AcquisitionLineRate}(lines/sec)}$$

Regardless of whether specifying speed or having it calculated, set your conveyor (or other device) to move exactly at a speed equal to **Scan3dMotionSpeedWorld** (which is read-only in **Step** mode); otherwise, you will acquire the object at the wrong aspect ratio.

Note that, to inquire the duration of one scan, use **AcquisitionFramePeriod**. To inquire the calculated scan step when specifying motion speed (Speed mode), use **Scan3dMotionEffectiveStepWorld** instead of **Scan3dMotionStepWorld**.

Once the scan length and motion speed are known, Zebra Altiz 4200 automatically calculates the acquisition frame rate (that is, the number of whole multi-profile surface scans per second) using the following formula:

$$AcquisitionFrameRate(frames/sec) = \frac{Scan3dMotionSpeedWorld(mm/sec)}{Scan3dVolumeEffectiveLengthWorld(mm/frame)}$$

If the frame rate is too low for your application, you can:

- Increase the scan step (that is, lower the density of profiles).
- Try to further reduce the scan area in Z to increase the maximum available line rate.
- Try reducing the exposure.

Specifying displacement when using a line (profile) trigger

To scan an object that is not moving at a constant speed, you need to use a line trigger to indicate when to acquire a profile. Although the line rate is not constant, the displacement of the object between triggers must be constant, and must be specified either directly or indirectly. This displacement is used to output a multi-profile surface scan with accurate Y-coordinates and Y-scale.

To enable the use of a line (profile) trigger, set **TriggerSelector** to **LineStart**, and then set **TriggerMode** to **On**. You will also need to set a source for the line trigger; to do so, set **TriggerSource**.

Non-encoder triggering

When not using an encoder as the line trigger source, you must explicitly specify the scan step (displacement); **Scan3dMotionInputType** can only be set to **Step**. Specify the scan step by setting **Scan3dMotionStepWorld** to a value in mm/line (profile) trigger. The maximum motion speed is automatically established using the following relationship:

$$Scan3dMotionSpeedMaxWorld(mm/sec) = Scan3dMotionStepWorld(mm/line) \times AcquisitionLineRateMax(lines/sec)$$

If you use a line trigger rate that exceeds the maximum possible line (profile) rate, lines will be dropped.

Encoder triggering

When using an encoder as the line trigger source, first set the distance between each encoder step using **EncoderResolution**, set in mm. You must then explicitly specify either the maximum expected motion speed or the scan step (displacement); Zebra AltiZ 4200 will automatically calculate the other and an appropriate encoder divider. The divider establishes after how many encoder steps to cause a line (profile) trigger. To specify which you will provide, set **Scan3dMotionInputType** to either **Speed** or **Step**, respectively. Then, specify the speed by setting **Scan3dMotionSpeedWorld** to a value in mm/sec, or specify the scan step by setting **Scan3dMotionStepWorld** to a value in mm. Calculations use the maximum acquisition line rate and the specified information as follows:

If you have set **Scan3dMotionInputType** to **Speed**, the following relationship is used to automatically calculate the encoder :

$$EncoderDivider(steps/line) = ceil\left(\frac{Scan3dMotionSpeedWorld(mm/sec)}{AcquisitionLineRateMax(lines/sec) \times EncoderResolution(mm/step)}\right)$$

The scan step is then computed automatically using:

$$Scan3dMotionEffectiveStepWorld(mm/line) = EncoderDivider(steps/line) \times EncoderResolution(mm/step)$$

If you have set **Scan3dMotionInputType** to **Step**, the following relationship is used to automatically calculate the encoder :

$$EncoderDivider(steps/line) = floor\left(\frac{Scan3dMotionStepWorld(mm/line)}{EncoderResolution(mm/step)}\right)$$

The motion speed is then computed automatically using:

$$Scan3dMotionSpeedMaxWorld(mm/sec) = Scan3dMotionEffectiveStepWorld(mm/line) \times AcquisitionLineRateMax(lines/sec)$$

Ensure motion speed is lower than **Scan3dMotionSpeedMaxWorld**; otherwise, lines will be dropped.

To use and set up the encoder interface, set **TriggerSelector** to **LineStart**, set **TriggerSource** to **Encoder0**, set **EncoderSourceA** and **EncoderSourceB** to the auxiliary lines on which to receive bit A and bit B (bit 0 and 1) of the 2-bit Gray code, and then, set **EncoderOutputMode** to the required output mode (the direction of movement upon which the encoder interface should output a pulse). Finally, set **EncoderReset** to the source that will reset the encoder position counter.

- ❖ Note that when **TriggerSource** is set to **Encoder0**, an appropriate encoder divider is automatically calculated; you cannot change **EncoderDivider** (it is read-only in this case).

A summary

The image below outlines the features that control various attributes of your scan.

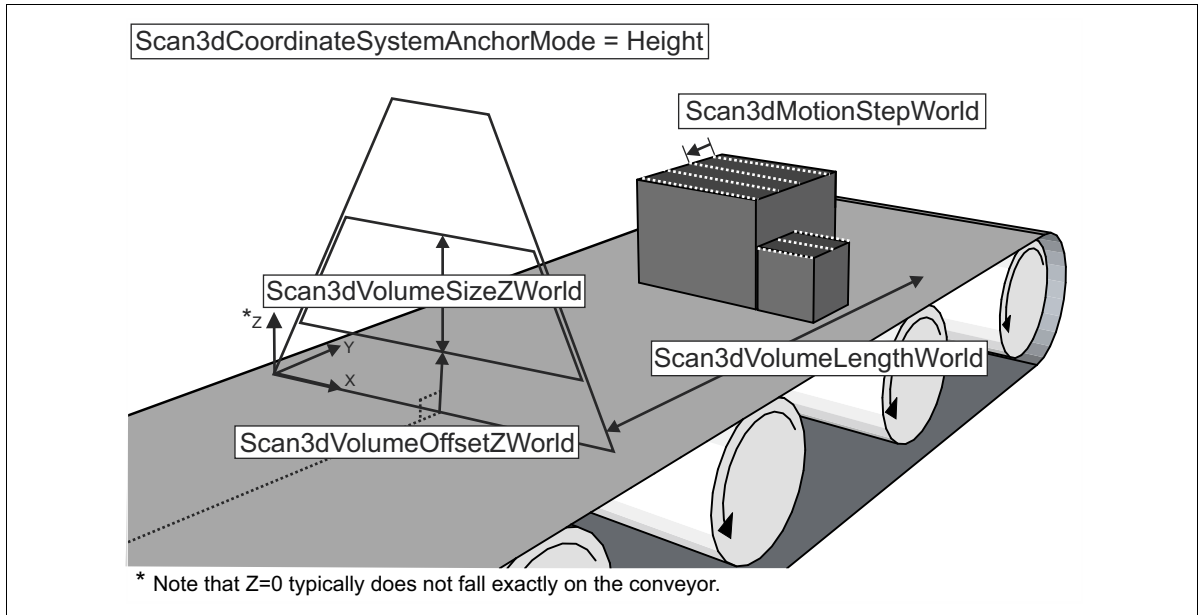

Scan step (displacement) and scan length, when combined, provide Zebra Altiz 4200 with the information needed to calculate the number of profiles required to scan the entire length of the target surface. The number of profiles corresponds to the number of rows in the range component, as described in the *Understanding how 3D depths and coordinates are established* section. This number is useful to know because it is one of the factors that will affect the frame rate for a given volume and speed. The formula for the number of profiles is the following, which is calculated automatically by Zebra Altiz 4200.

$$\text{Number of profiles} = \text{ceil}\left(\frac{\text{Scan3dVolumeLengthWorld}}{\text{Scan3dMotionStepWorld}}\right) + 1$$

Setting up frame triggers for single-profile scans or multi-profile surface scans

Upon an **AcquisitionStart** command¹, Zebra AltiZ 4200 performs single-profile scans or multi-profile surface scans. In the latter case, by default, each scan ends when the specified length (**Scan3dVolumeLengthWorld**²) of the object's surface has been scanned. Scans are captured continuously, until stopped with the **AcquisitionStop** command¹.

By default, the **AcquisitionStart** command causes Zebra AltiZ 4200 to start scanning immediately, starting each subsequent scan immediately after the preceding one ends. To start each scan upon a trigger signal (for example, when an object passes in front of a sensor), enable and configure the frame start trigger before issuing the **AcquisitionStart** command. Set **TriggerSelector** to **FrameStart** and then set **TriggerMode** to **On**. You also need to set **TriggerSource** to the source of the frame trigger.

To control when each profile (row) of the scan is acquired (for example, when the object is not moving at a constant speed), enable and configure a line start trigger before issuing the **AcquisitionStart** command. This corresponds to the trigger that starts the capture of the laser line image from which the profile is extracted. Set **TriggerSelector** to **LineStart**, set **TriggerMode** to **On**, and set **TriggerSource** to the source of the line (profile) trigger.

If using both a frame trigger and a line (profile) trigger, each scan starts upon the first line trigger received on or after the frame trigger. Any trigger received before the frame trigger is ignored. You can also use a line trigger without using a frame trigger; in which case, upon the **AcquisitionStart** command, Zebra AltiZ 4200 waits for the first line trigger before initiating the scan.

-
1. Note when using Aurora Imaging Capture Works, Aurora Imaging Library, or Aurora Imaging Design Assistant, **AcquisitionStart** and **AcquisitionStop** are automatically handled for you.
 2. The features mentioned in this section have both regular and quick access names. This section refers to them by their regular names. For more information, see the *Quick setup* subsection of the *Steps to performing basic 3D scans with Zebra AltiZ 4200* section earlier in this chapter.

When **TriggerSelector** is set to **FrameStart**, you need to wait for the entire frame to end before another frame can be captured, which might result in acquiring more than one scanned object per frame, or having to wait for a frame to end before initiating another acquisition. To ensure that there is only one scanned object per frame and that the frame ends when the object has passed the laser line, enable and configure a **FrameActive** trigger. Set it to use Zebra AltiZ 4200 object detection or to use a proximity sensor, which sends an active signal while it detects an object that Zebra AltiZ 4200 should scan. Zebra AltiZ 4200 will acquire profiles for as long as the **FrameActive** trigger is active and will end the frame when the object is no longer sensed. Set **TriggerSelector** to **FrameActive** and set **TriggerMode** to **On**; then, set **TriggerSource** to **ObjectDetect** or the line that is connected to your proximity sensor. When using a line that is connected to your proximity sensor, set **TriggerActivation** appropriately.

Using **ObjectDetect** as a trigger source

Instead of using an auxiliary line, timer, or counter, you can set **TriggerSource** to **ObjectDetect** to start a grab when Zebra AltiZ 4200 detects an object within a region of the scan area. If the object is of a known length, set **TriggerSelector** to **FrameStart**, so that the end of frame occurs when the end of **Scan3dVolumeLengthWorld** is reached. If the object is of a variable length, set **TriggerSelector** to **FrameActive**, so that the end of frame occurs when a continuous gap along the Y-axis, as specified by **ObjectDetectGapY**, is encountered after the object, or **Scan3dVolumeLengthWorld** is reached.

To detect an object, use **ObjectDetectThresholdZ** to set the Z-threshold that delimits the region along the Z-axis in which to detect an object. Specify Z relative to the selected Anchor coordinate system position. For an object to be detected, an object must be found between **ObjectDetectThresholdZ** and the near FoV.

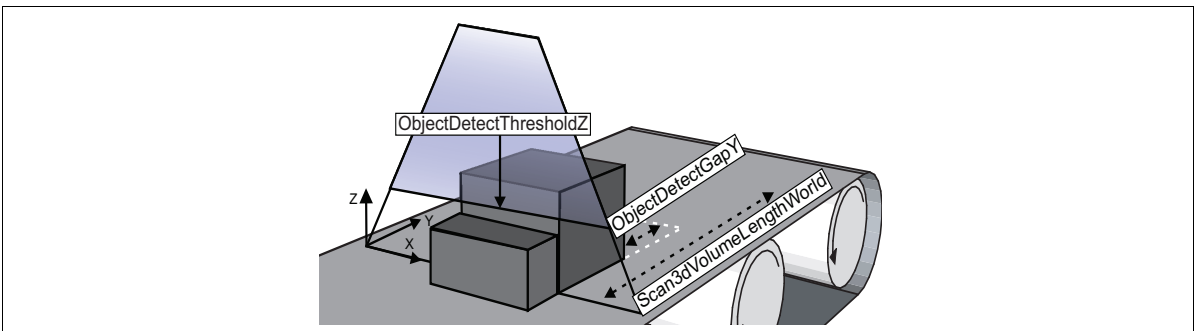

In the diagram above, the first box will pass below **ObjectDetectThresholdZ**, which means the grab will not be initiated. Once the larger box passes between **ObjectDetectThresholdZ** and the near FoV, the grab will initiate. Acquisition will continue for as long as a portion of the object is between **ObjectDetectThresholdZ** and the near FoV, and complete once the end of **ObjectDetectGapY** is reached (if **TriggerSelector** is set to **FrameActive**) or until the end of **Scan3dVolumeLengthWorld** is reached.

If you have guard railings, or other barriers along your scan area, you can use **ObjectDetectRegionStartX** and **ObjectDetectRegionEndX** to define the region along the X-axis in which to detect objects. This ensures that the guard railings don't trigger a grab. When an object is detected within **ObjectDetectRegionStartX** and **ObjectDetectRegionEndX**, and is between the **ObjectDetectThresholdZ** and near FoV, a grab will start.

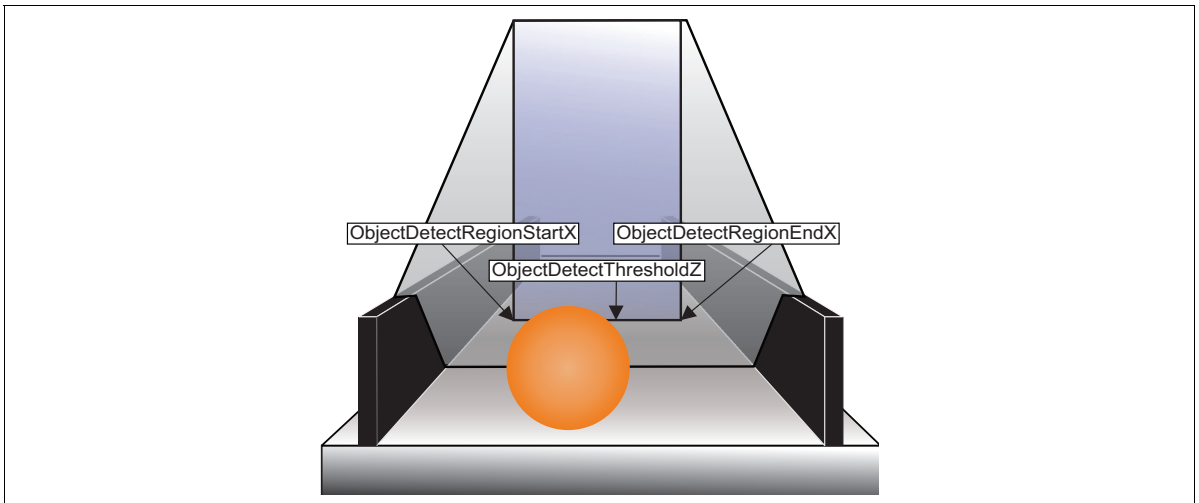

Note that the object detection region is only used for triggering purposes. Zebra AltiZ 4200 will always scan the defined scan area (**Scan3dVolumeSizeZWorld**, **Scan3dVolumeOffsetZWorld**, and the maximum X of your model type).

You can filter out debris by setting a minimum area (in mm^2) that an object must have when projected on the XY-plane, using **ObjectDetectMinimumXYArea**. If an object is smaller than **ObjectDetectMinimumXYArea**, then it is assumed that an object has not actually been detected, and grabbed data is discarded. All peaks inside of the object detection region along the length of the object are used to calculate the area of an object, even if some peaks are not contiguous. If the grabbed data is discarded, **ObjectDetectTotalRejected** is incremented. If an object is greater than **ObjectDetectMinimumXYArea**, then **ObjectDetectTotalAccepted** is incremented. To reset these statistics, use **ObjectDetectResetStatistics**.

A pre-established number of profiles taken prior to detecting an object can also be transmitted along with the acquired object data. To enable transmitting the preceding profiles, set **ObjectDetectPrecedingProfiles** to **True**.

Setting up acquisition trigger delays

When using an external device as a trigger source, you might need to delay the start of a scan after receiving an acquisition trigger. The most common way to do so is with a timer. To set an acquisition trigger delay using a timer, set **TimerSelector** to **TimerN**, and then set **TimerTriggerSource** to the acquisition trigger signal that you want to delay (for example, **Line 0**); this signal will now initiate the timer instead. Next, set **TimerTriggerActivation** to the edge that your timer will trigger on (for example, **RisingEdge**), and set **TimerDelay** to the delay you require, in μsec (for example, $100 \mu\text{sec}$). Finally, set **TriggerSource** for the frame start or line (profile) trigger (**TriggerSelector**) to the selected timer (**TimerNStart**).

Zebra AltiZ 4200 data output components and their definitions

Zebra AltiZ 4200 can transmit the following data output components, extracted from various stages in the processing pipelines. To enable a component, select the component with **ComponentSelector**, and set **ComponentEnable** to **True**; you should only enable required components because transmitting additional components reduces the maximum frame rate. Some of these components might not be available with certain settings.

- **Range component.** Stores 3D distance or position information. If **Scan3dOutputMode** is set to **RectifiedC**, the range component is stored in **Coord3D_C16** pixel format, and the 3D sensor is said to output its 3D data in depth map format¹. If **Scan3dOutputMode** is set to **CalibratedABC_Grid**, the range component is stored in **Coord3D_ABC32f_Planar** pixel format, and the 3D sensor is said to output its 3D data in point cloud format.
- **Confident component.** Stores confidence information for the range component, in **Confidence8** pixel format. Each pixel of the confidence component indicates whether the value at the corresponding position in the range component was detected by the image sensor. If the peak was seen by the sensor, it has a confidence of 255, while a peak that was not seen by the sensor has a confidence of 0.
- **Reflectance component.** Stores a reflectance map in **Mono8** pixel format. Each pixel of a reflectance map indicates the approximate intensity of the laser line at the point at which the peak was extracted.
- **Scatter component.** Stores a laser line scatter map, in **Data8** pixel format. This corresponds to the approximate width of the laser line, measured in pixel units, in the column from which the peak was extracted.

1. When outputting 3D data in depth map format, a value of 0 in the range component might indicate that either no peak was seen (if the associated confidence value is 0), or the calculated Z-value of the peak was too high or too low to be stored in the range component (if the associated confidence value is not 0). The latter can happen when the **Scan3dMotion-Pitch** feature is modified.

- **Intensity component.** Stores a grayscale image of light in the visible spectrum (filtered), in Mono8 pixel format. Note that the intensity image is the raw camera laser line image with corrections applied. This is the image of the laser line. This component is only available when outputting a single-profile scan (that is, when `Scan3dVolumeLengthWorld` is set to 0).
- **Peak0 and Peak1 components.** Store the Y-coordinates of the extracted peaks, in the pixel coordinate system of the laser line image; this is stored in Data16 pixel format. Note that the intensity image is the raw camera laser line image with corrections applied. This is useful to display the locations of the extracted peaks on top of the laser line image (intensity component of a single-profile scan). Values are encoded with 5 bits of fixed-point precision. The value 65535 denotes the absence of a peak. These components have the GenICam custom component types 1 and 2, respectively (that is, 0xFF01 and 0xFF02).
- **PeakSource component.** Stores a Data8 bitfield that indicates from which of the two extracted peak(s) (Peak0 and Peak1 components), the depth/position stored in the range component originated. This component has the GenICam custom component type 0 (that is, 0xFF00). The table below identifies which bits are set for which peaks.

Bit	7	6	5	4	3	2	1	0
PeakSource	0	0	0	0	0	0	Source0 Peak1	Source0 Peak0

Group ID

All the components transmitted by the image sensor are transmitted in group 0.

Zebra Altiz 4200 workflow

Once an image of the laser line is taken from the image sensor, the peaks in each column are processed to establish which peak is the correct peak for a particular column and what is its corresponding depth/position. The peak processing workflow involves peak extraction and selection. At each stage in the peak processing workflow, different data output components are available.

The following is the complete possible workflow, but it is rare to enable it all. Zebra distributes user sets with common workflows that you can use as starting points. Note that the intensity component is available for output only for a single-profile scan.

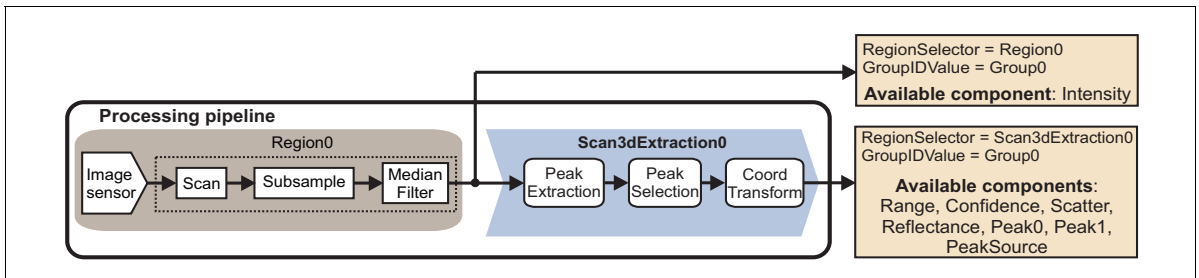

Distributed user sets

Zebra Altiz 4200 supports user sets, which are a collection of pre-defined settings that can be saved and loaded. This makes it simple to select one user set and have all of the settings associated with that user set update at once. Zebra distributes user sets with common workflows that you can use as starting points; you can load a user set using **UserSetLoad**. The workflows of these user sets are simplified versions of the complete workflow presented in the previous section.

To keep any modifications to the feature settings, you can save the current value of all the settings to a custom (writable) user set: **UserSet0**, **UserSet1**, **UserSet2**, or **UserSet3**. To do so, use the **UserSetSave** feature. Note that by default, the non-writable Profile user set is loaded on reboot. You can change the user set that is loaded on reboot using the **UserSetDefault** feature.

- ❖ Note that when you change from one user set to another, the values of all features will be overwritten; take note of the required features values before changing.

Intensity user set

The Intensity user set is used to allow you to visualize the laser line so that you can position your Zebra AltiZ 4200, as well as see where the laser light bounces on a particular object. Below is the workflow diagram for the Intensity user set:

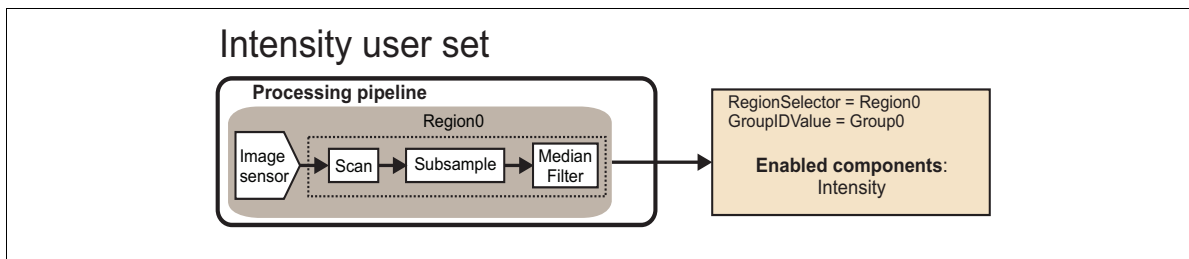

When using this user set, a default exposure time of 10000 μs is used and only the intensity component is enabled for output. This user set does not output 3D data and all the control settings, other than exposure time and output component, use the same default control settings found in the Profile user set.

Setup user set

The Setup user set allows you to validate the setup and establish the required settings for proper peak extraction. Use the Setup user set if you find the default values are not sufficient. This user set is configured to perform a single-profile scan in **ReferencePoint** mode. Below is the workflow diagram for the Setup user set:

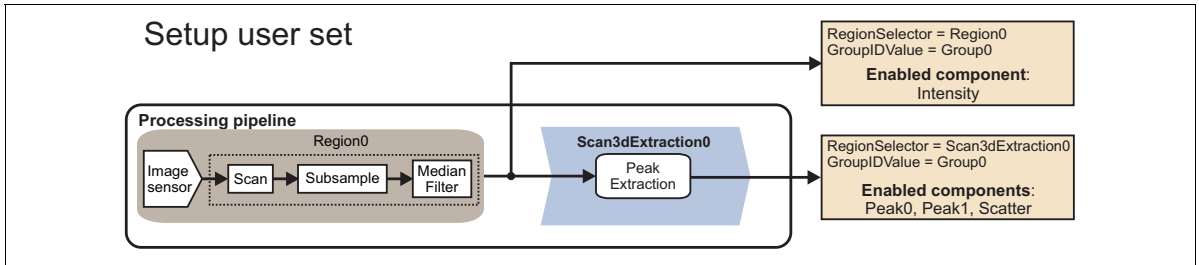

When using the Setup user set, the laser line image, stored in the intensity component before peak extraction, can be used to determine whether your laser brightness, exposure, and other initial acquisition conditions are appropriate. If the intensity is too low, you will have to adjust these acquisition conditions until the intensity has an optimal contrast, without too much saturation. See the *Laser control and exposure* section for information on how best to adjust laser intensity. If you are still having problems with your acquisition, after having adjusted the laser intensity, see the *Adjusting peak extraction settings* section for more information on setting appropriate extraction settings. In this user set, a single-profile scan is performed (that is, **Scan3dVolumeLengthWorld** is set to 0).

The Peak0 and Peak1 components store the Y-coordinates of the initially extracted peaks, in the pixel coordinate system of the laser line image (intensity component). These components are useful to display the locations of extracted peaks on top of the laser line image.

Profile and Surface user sets

The Profile and Surface user sets are typically used once you know how to setup Zebra AltiZ 4200. You typically only use one of these user sets as a starting point for creating a custom user set for runtime scanning. You typically only need to change those features established using the Setup user set¹. By default, the Profile user set is in **ReferencePoint** mode, and the Surface user set is in **Height** mode. Below is the workflow diagram for these user sets:

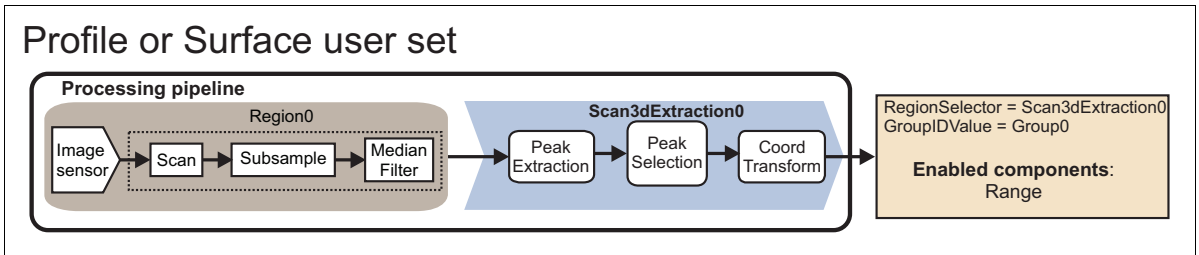

By default, only the range component is enabled for output. For the other components that you can enable for output from the different pipelines, see the complete possible workflow in the Zebra AltiZ 4200 workflow section. Note that when using the Surface user set, you cannot output the intensity component.

Once you have adjusted the feature settings loaded by the selected user set, you can save them to a custom (writable) user set: UserSet0, UserSet1, UserSet2, or UserSet3.

-
1. Aurora Imaging Capture Works offers a way to establish appropriate values and automatically configure a user set with these values (you don't have to manually enter values established with one user set into another). For information, see the Aurora Imaging Capture Works user guide

Peak processing

Once the laser and exposure features have been set appropriately, you can, if still necessary, adjust the features that control extraction and selection of peaks. The workflow of a peak from extraction to selection is outlined in the diagram below:

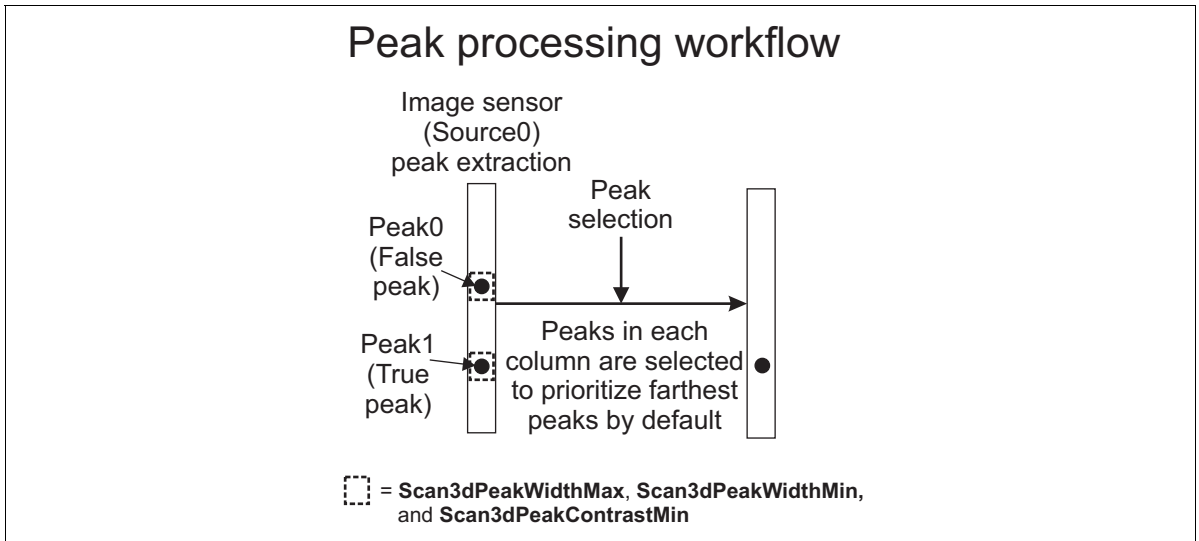

Adjusting peak extraction settings

When scanning your object, the image sensor captures one true peak per column. The default peak extraction settings, along with an appropriate laser brightness and correct exposure time, are typically sufficient to provide you with acceptable 3D data of your scanned object. Adjusting peak extraction settings is useful in situations where, even after adjusting the laser brightness, exposure time, and ensuring the laser line is not occluded, you find there are gaps in the depth map or insufficient points in your 3D point cloud. This could happen on materials that reflect the laser light differently on different parts of their surface (for example, if there are multiple colors next to one another with different reflectance qualities, such as black and white).

To extract the peaks in an image, you need to define the peak's width and contrast. To set the width, specify the peak's maximum width and minimum width. The maximum width specifies the expected maximum width of a peak in a column; to specify this, set **Scan3dPeakWidthMax** to an appropriate value in pixel units. To specify the minimum width, set **Scan3dPeakWidthMin** to an appropriate

value in pixel units. Contrast dictates the minimum difference between the intensity of the local background and that of the prospective peak; to specify this, set `Scan3dPeakContrastMin` to an appropriate value in gray level units.

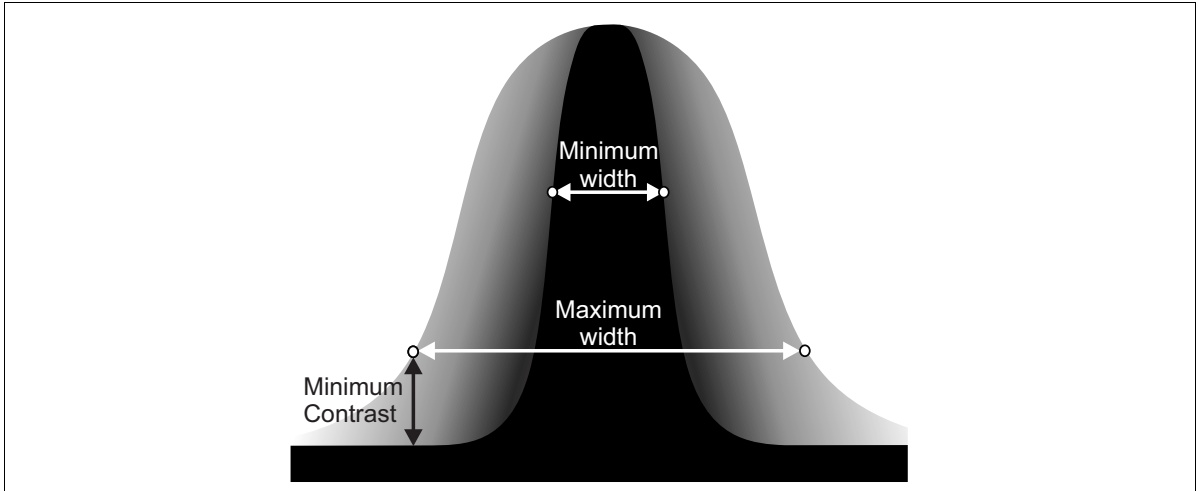

Peak reflectance is the average value of the few pixel intensities around the position of the peak in the same column. You can specify the size of the vertical window around the peak from which the average is taken, with `Scan3dPeakReflectanceWindowSize` in pixel units.

Adjusting peak selection settings

Once the peaks are extracted, you can still end up with more than one peak in a given column. So that only one peak is left in the column, select which peak to output. To do so, set `Scan3dPeakSelectionMode` to **Brightest**, **Closest**, or **Farthest**.

Adjusting the resolution along the X-axis

Zebra AltiZ 4200 outputs uniformly sampled profiles, so that the distance between two adjacent points of a profile is the same along the X-axis. This means that the resolution along the X-axis is constant across the field of view (FoV) regardless of the elevation. By default, Zebra AltiZ 4200 uses the resolution of the furthest end of the field of view (FoV) to sample data along the X-axis so that the resolution along the X-axis is constant across the entire FoV.

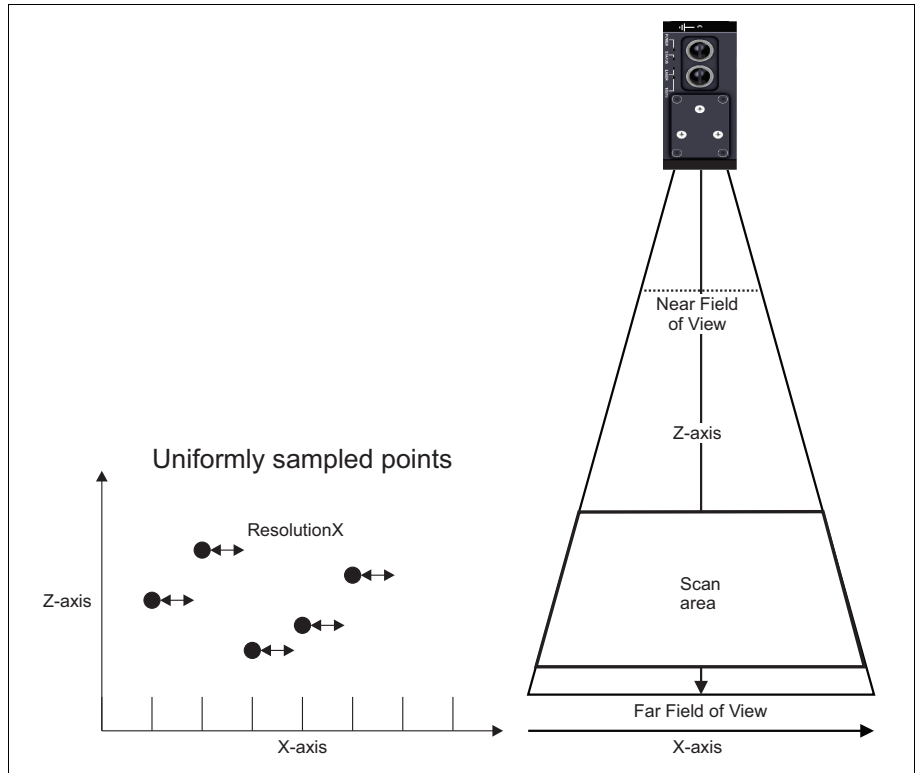

There might be a case where you need to change the resolution of your scans along the X-axis (for example, if you require more data along the X-axis for your use case, or if you need the resolution along the X-axis to be closer to the resolution along the Y-axis). When you are working with a scan area that is smaller than the entire available range and closer to the near FoV, you can change the resolution along the X-axis using the **ResolutionX** feature.

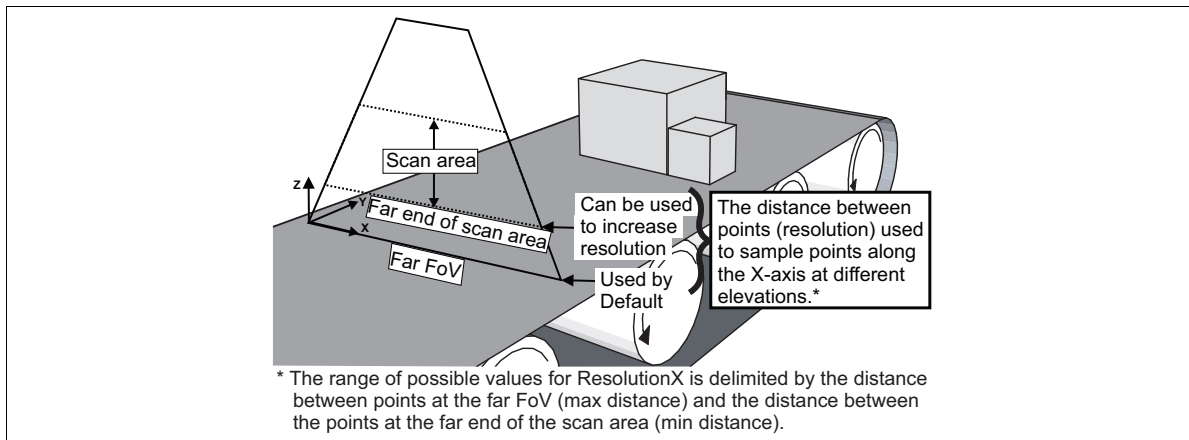

To adjust the resolution along the X-axis, first set a scan area by setting **Scan3dVolumeZMode** to **Configurable** and adjusting the scan area using both **Scan3dVolumeOffsetZmode** and **Scan3dVolumeSizeZmode**. You can only increase the resolution up to that of the furthest end of the scan area. For more information on how to set a scan area, see the *Modifying scan area, scan length, and scan step* section earlier in the chapter. Once you have set the scan area, set **ResolutionX** to the required distance along the X-axis between adjacent points, in mm. The maximum possible distance, along the X-axis, between adjacent points depends on your model of Zebra AltiZ 4200; the minimum distance depends on the furthest end of the scan area.

If the value that you enter for **ResolutionX** cannot be achieved, the closest supported resolution will be used, as returned by **EffectiveResolutionX**. **EffectiveResolutionX** returns the actual distance used between two points along the X-axis, in mm, given your setup. Adjusting **Scan3dVolumeOffsetZWorld** so that the scan area is closer to the near FoV will increase the range of possible **ResolutionX** values. If the resolution that you entered is not possible given your current setup, you will need to increase **Scan3dVolumeOffsetZWorld** so that the scan area is closer to the near FoV, or accept the value of **EffectiveResolutionX** as the resolution that will be used along the X-axis in your scan.

- ❖ Note that changing **ResolutionX** does not change the acquisition speed (nor the width of the range component). It changes the sampling of data used to achieve a constant resolution along the X-axis regardless of the elevation.

Correcting for Zebra AltiZ 4200 rotation

Ideally, Zebra AltiZ 4200 should be setup so that the direction of motion is perpendicular to the laser plane. If this is not possible in your setup, you will need to account for the skew that will result from such a setup.

To compensate for the rotation of Zebra AltiZ 4200 around the X-axis, where the laser plane is not perfectly perpendicular to the direction of motion, you will need to adjust the pitch, using `Scan3dMotionPitch`. To compensate for the rotation of Zebra AltiZ 4200 around the Z-axis, where the direction of motion is not perfectly perpendicular to the laser plane, you will need to adjust the yaw, using `Scan3dMotionYaw`.

Pitch around the X-axis will cause a skew between the Z-axis and Y-axis in the scanned image, which will produce an inaccurate thickness (depth/Z-values). Once a correction using `Scan3dMotionPitch` is used to appropriately adjust this skew, the 3D points of your resulting scan will be accurate but will appear at a slant that represents the slant of Zebra AltiZ 4200 when scanning. If you want to measure the thickness of your object, use software to fit a plane to the background and project the resulting points down.

The diagram below provides a visualization of pitch, the skew it creates, and what its correction looks like.

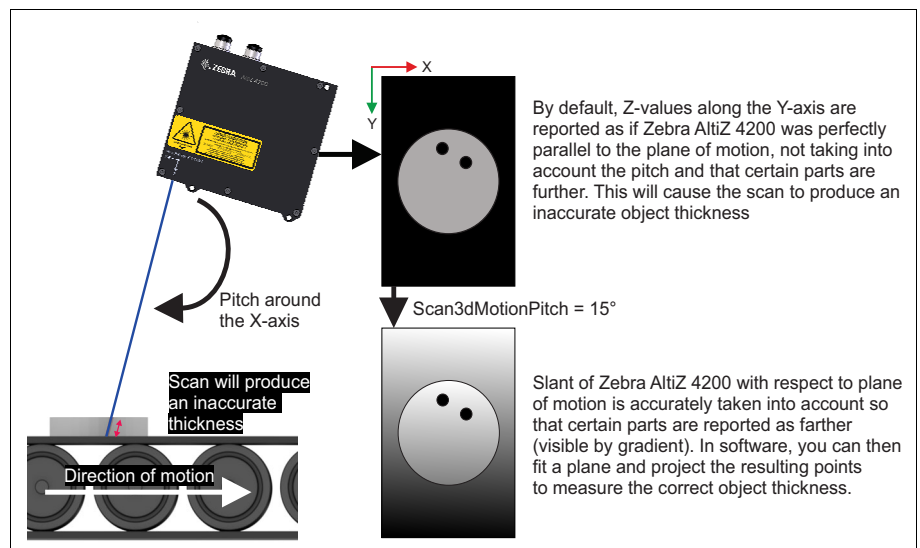

Yaw around the Z-axis will cause a skew between the X-axis and Y-axis in the scanned image, which will produce a distorted result. Once a correction using **Scan3dMotionYaw** is used to appropriately adjust these skews, the 3D points of your resulting scan will be accurate.

The diagram below provides a visualization of yaw, the skew it creates, and what its correction looks like.

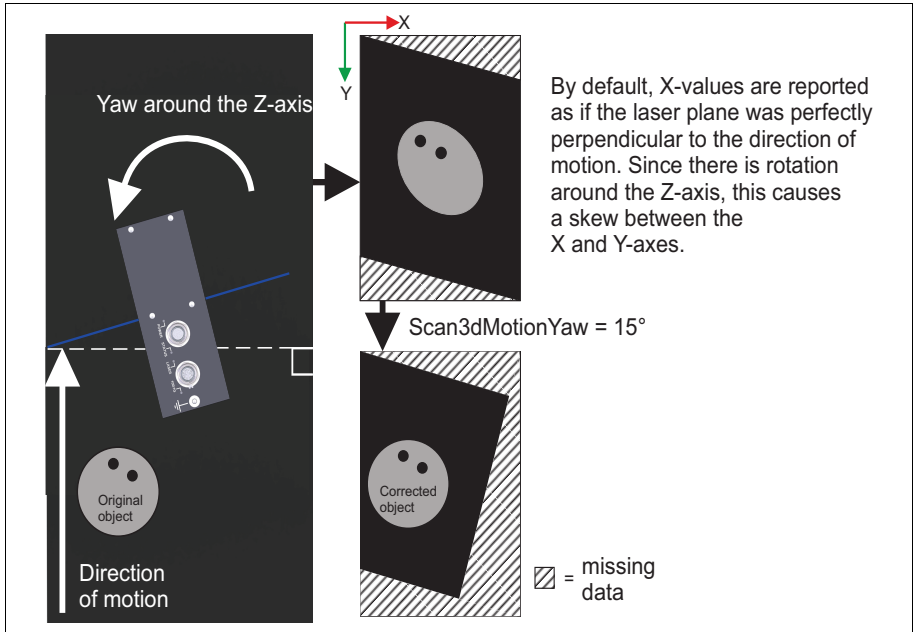

- ❖ Note that if a rotation is only around the Y-axis, it does not cause a skew. If you need to adjust for this rotation, you can set a transformation. For information on how to set a transformation, see the *Outputting a point cloud or depth map* section later in this chapter.

Risk of losing data when outputting in depth map format

When you set a pitch and/or yaw value (**Scan3dMotionPitch** and/or **Scan3dMotionYaw**), there is the risk of losing data when outputting it in a depth map format (**RectifiedC**). Since a depth map represents the X and Y-coordinates of the data by the column and row in which it is written, respectively, any skewed values that end up outside the maximum number of columns (X-axis) of the depth map after they have been corrected will be lost (and any pixels without corresponding points will be set to the missing data value). Similarly, any skewed values that end up outside the maximum pixel value (Z-axis) of the depth map

after they have been corrected will be saturated. Depending on your application, the lost data might not be relevant or affect your required results. If you find that there is too much loss of data from the correction, you can transfer it to the Host for software correction; here, you can convert the data to a point cloud or use a bigger destination buffer for the resulting depth map. This limitation does not appear when outputting data in a point cloud format (**CalibratedABC_Grid**). For more information on how 3D coordinates are established in a depth map, see the *Understanding how 3D depths and coordinates are established* section earlier in the chapter.

Establishing appropriate pitch and yaw values

The values that you use for pitch and yaw will depend on your application. You can use the **AltiZAlignLaserScans.cpp** example available in Aurora Imaging Library, along with an alignment disk, to establish the required values for pitch and yaw correction. The dimensions for creating an alignment disk are found in the PDF included with the **AltiZAlignLaserScans.cpp** example, but they can be modified to suit your specific application. The following constraints must be met if using an alignment disk:

- The alignment disk must cover at least 50% of the scanned width (X-axis).
- The alignment disk must cover enough area of the scan.
- The alignment disk's edge must be fully visible in the scan.
- The alignment disk must cover at least 30% of the scanned length (Y-axis).
- The alignment disk must have two circular holes represented with at least 30 scan lines (Y-axis) and 30 points (X-axis). The radii of the holes must be within 5 to 10% of the disk's radius and the depth of the holes must be at least 20% the total disk's height.
- The floor (background) must be present in the scan.

If you have pre-calculated values that you need to use for pitch and yaw, you can apply them without needing to run the alignment example.

Outputting a point cloud or depth map

Zebra AltiZ 4200 can output a depth map or a point cloud. By default, Zebra AltiZ 4200 outputs a depth map.

If outputting a depth map, the final step in peak processing converts the selected peaks to real world depths and stores them in the range component. If outputting a point cloud, they are converted to explicit XYZ coordinates. Set **Scan3dOutputMode** to **RectifiedC** for a depth map or **CalibratedABC_Grid** for a point cloud. For more information, see the *Understanding how 3D depths and coordinates are established* section earlier in this chapter.

When outputting a point cloud, you can have the output coordinates be, for example, with respect to the conveyor, using the Transformed coordinate system. To use this coordinate system as your reference, set **Scan3dCoordinateSystemReference** to **Transformed**. Assuming Zebra AltiZ 4200 is positioned vertically, with the laser plane perfectly perpendicular to the direction of motion, and you want to place $Z=0$ on the conveyor surface, set **Scan3dCoordinateTransformSelector** to **TranslationZ**; then set **Scan3dTransformValue** to an appropriate value in mm (world units). If you output coordinates in the Transformed coordinate system, you will only be able to output the coordinates in **CalibratedABC_Grid** (that is, a point cloud).

If you are mounting Zebra AltiZ 4200 3D sensors in multi-device configuration, you can also transform all of their coordinate systems to be aligned to a single coordinate system.

Vibration compensation

Zebra AltiZ 4200 provides vibration compensation when **VibrationEnable** is set to **True**. This feature allows Zebra AltiZ 4200 to calculate the vibration expected for each profile, along the Z-axis, removing vibration distortions on a surface scan in real time.

Vibration compensation requires an established location of the floor along the X-axis, which is constant throughout the scan. You can also choose to give the height of the floor in the Z-axis (for example, the X and Z axis of an empty location on a conveyor belt), to increase accuracy in establishing the floor. The location of the floor acquired throughout the scan is established using **VibrationFloorStartX**, **VibrationFloorEndX**, **VibrationFloorStartZ**, and **VibrationFloorEndZ**.

VibrationFloorStartX sets the start location of the floor along the X-axis, which is continuously visible by the sensor's FoV during acquisition, but is not covered by the scan object. Ensure the space between **VibrationFloorStartX** and **VibrationFloorEndX** is wide enough to properly establish the default floor location. You can also set a range for the height of the floor along the Z-axis by setting **VibrationFloorStartZ** and **VibrationFloorEndZ**. This range is set so that the location of the floor always remains between **VibrationFloorStartZ** and **VibrationFloorEndZ** as it vibrates up and down. When scanning, ensure that the scanned object does not cover the floor you established with the **VibrationFloor** features

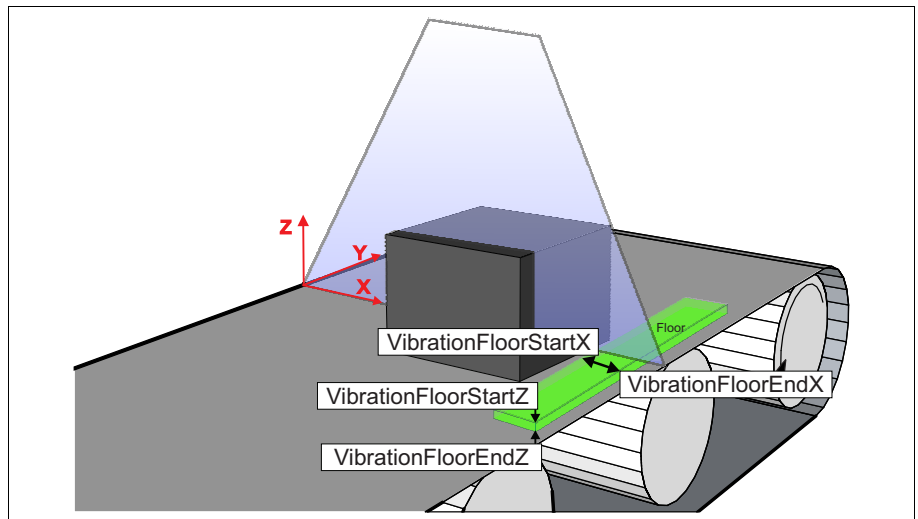

Increasing Zebra AltiZ 4200 acquisition speed

Once you have made necessary adjustments to all your extraction features, you might find that you need to speed up your acquisition time, or need a higher resolution (number of profiles per mm) in the direction of motion. To achieve this, you can reduce the scan area or use subsampling.

Increasing acquisition speed by reducing the scan area

Reducing the scan area along the Z-axis reduces the height of the laser line image. This speeds up processing and new images can be acquired faster. Be aware that although reducing the scan area along the Z-axis increases acquisition speed, this reduces the possible range of Z-coordinates. For information on how to set scan area, see *Scan area* subsection of the *Modifying scan area, scan length, and scan step* section earlier in the chapter.

Increasing acquisition speed using subsampling

To speed up acquisition time, Zebra AltiZ 4200 can perform vertical subsampling on the laser line images before peak extraction. To control vertical subsampling, use **DecimationVertical**; this reduces the resolution in height. When performing vertical subsampling, the resolution of the peaks is affected, but the number of peaks remains the same. You can set **DecimationVertical** to a decimation factor of 2. By default, the decimation factor is set to 1, which means no subsampling is performed.

The graph below illustrates expected acquisition speeds when using standard mode or vertical subsampling:

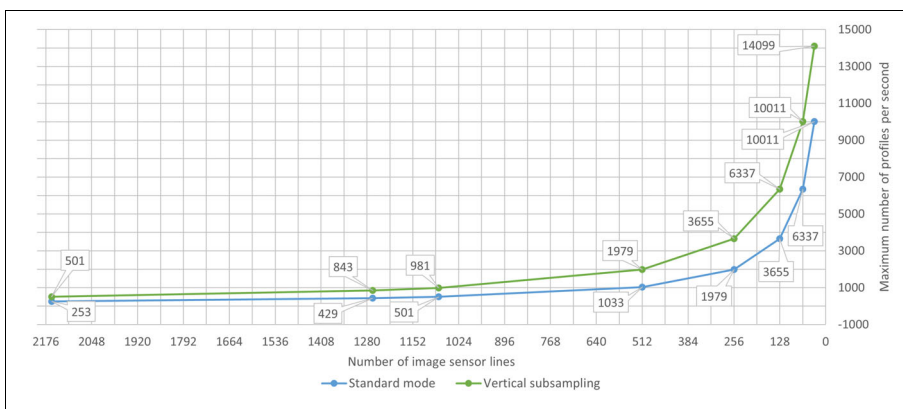

Chapter

5

Zebra Altiz 4200 GenICam feature reference

This chapter describes the Zebra Altiz 4200 GenICam features.

Zebra Altiz 4200 GenICam features

This chapter lists both custom and standard GenICam features found under Zebra Altiz 4200 in the Feature Browser. For more information about the GenICam standard, refer to the GenICam Standard Feature Naming Convention, available on the GenICam website at: emva.org/standards-technology/genicam. For information on how to use these features with Zebra Altiz 4200, see *Chapter 4: Understanding and setting the features of your Zebra Altiz 4200*.

Aurora Imaging Capture Works provides code snippets for each GenICam feature. These snippets can be copied directly into your Aurora Imaging Library code, or if not using Aurora Imaging Library, copied and appropriately adjusted.

Note that this chapter lists the features in the order that they appear in Aurora Imaging Capture Works. Some features might only be available in Guru mode.

As per the GenICam standard

Selector features

In situations where multiple instances of a feature exists (for example, the timer duration for each available timer), a selector feature is used to index the instance to access/modify. A selector feature is a separate feature whose name ends with **Selector** and is typically an IEnumeration or an Integer. A selector feature selects the target features for subsequent changes. In this document, if a feature is dependent on a selector, the selector is listed in square brackets below the feature name.

Same name, same feature

In some cases, a feature appears in multiple categories. This is only for clarity or convenience when accessed through a GUI (such as, Aurora Imaging Capture Works). If a feature has the same name, it is the same feature. This is also true for selector features. For example, the **TriggerSelector** feature appears in multiple categories; however, if you change it, it affects all subsequent features that are dependent on the **TriggerSelector** feature, regardless of category.

Settable features can also be inquired

Note that all features that are settable can also be inquired. This only applies to features that are settable and not to features that are commands.

Quick Setup Control

The **Quick Setup Control** category groups together all features required to perform a scan using Zebra AltiZ 4200. This category is meant to facilitate rapid access to essential features when using an interface such as Aurora Imaging Capture Works. Some of these features are the exact same features as those found in other categories (for example, **AcquisitionLineRate** and **TriggerSelector**). Other features, prefixed with **QuickSetup**, are quick setup versions of features without the prefix found in other categories. Changing features in either location updates them in both locations. Note that the list of features that appear in the **Quick Setup Control** category changes dynamically, so that only those features related to your current settings are available.

Feature name	Description	
	Feature value	Description
Scan3dUsageMode	Returns the scan mode that Zebra AltiZ 4200 is currently set to use. When features that affect the mode are modified (such as Scan3dVolumeLengthWorld), this feature will automatically update. This feature is useful to know if Zebra AltiZ 4200 is set to perform a single-profile scan or a multi-profile surface scan. To establish the format in which the data is transmitted (depth map or point cloud), see Scan3dOutputMode instead. This feature is read only.	
	Profile	Specifies Zebra AltiZ 4200 will output a single-profile scan.
	ProfileAndIntensity	Specifies Zebra AltiZ 4200 will output a single-profile scan, and the laser line image from which the 3D data was extracted. The latter will be transmitted in the intensity component of the scan.
	Intensity	Specifies Zebra AltiZ 4200 will output the intensity component.
	Surface	Specifies Zebra AltiZ 4200 will output a multi-profile surface scan.
Scan3dVolumeLengthWorld	Sets the scan length (length of the surface to scan) along the direction of motion, in mm (world units). Note, you should include the distance from the start of the scan (frame trigger) until the end of the object. To only acquire a single profile, set this to 0. When this value is changed from 0, Scan3dUsageMode updates to Surface and additional features appear in the Quick Setup Control category. Changes to Scan3dVolumeLengthWorld can have an effect on AcquisitionFrameRateMax . By default, this feature is set to 0 (single-profile scan). This setting automatically adjusts the height of the output components (that is, the number of profiles taken); see the Height feature.	
AcquisitionLineRate	Sets the acquisition rate at which line profiles (laser line images) are captured, in lines/sec (that is Hz). To specify an explicit value, AcquisitionLineRateEnable must be set to True . If you specify a value greater than the maximum, you will get an error. If the maximum changes so that it becomes smaller than the current value of AcquisitionLineRate , AcquisitionLineRate is automatically set to the maximum. By default, this feature is set to AcquisitionLineRateMax and is read only.	

Feature name	Description	
	Feature value	Description
AcquisitionLineRateEnable	Sets whether AcquisitionLineRate is writable and can be set manually. By default, this is set to False .	
	True	Specifies AcquisitionLineRate must be set manually.
	False	Specifies AcquisitionLineRate is automatically set to AcquisitionLineRateMax .
Scan3dCoordinateSystemAnchorMode	Sets the Anchor coordinate system mode. The mode establishes the position and orientation of the Anchor coordinate system. For information on where these positions are in relation to Zebra Altiz 4200, see <i>Anchor coordinate system modes</i> section, in <i>Chapter 4: Understanding and setting the features of your Zebra Altiz 4200</i> . By default, this feature is set to ReferencePoint .	
	Distance	Specifies that the origin of the Anchor coordinate system, when facing the connectors of Zebra Altiz 4200, is at the near FoV aligned with the left edge of the far FoV. In this mode, the orientation matches the Y-Z reference mark (on the body of Zebra Altiz 4200). In this mode, all X and Z-coordinates are positive.
	Height	Specifies that the origin of the Anchor coordinate system, when facing the connectors of Zebra Altiz 4200, is to the left edge of the far FoV, and at the beginning of the far FoV. In this mode, the orientation of the Z-axis points towards the body of Zebra Altiz 4200, with the Y-axis pointing in the opposite direction from the Y-Z reference mark. In this mode, all X and Z-coordinates are positive.
	ReferencePoint	Specifies that the origin of the Anchor coordinate system is approximately located at the Y-Z reference mark, with the X-coordinate centered along the width of the body. The orientation matches the Y-Z reference mark. In this mode, X-coordinates can be positive or negative, and all the Z-coordinates are positive. Note that when using the Multi-Altiz Plugin, ReferencePoint is set by default.
QuickSetupRange Alternative: [ComponentSelector]{Range} and [ComponentEnable]{True} or {False}	Sets whether to enable for output the range component from the 3D reconstruction pipeline. This component stores 3D distance or position information. If Scan3dOutputMode is set to RectifiedC , the range component is stored in Coord3D_C16 pixel format. If Scan3dOutputMode is set to CalibratedABC_Grid , the range component is stored in Coord3D_ABC32f_Planar pixel format. This component is available when RegionSelector is set to Scan3dExtraction0 .	
	True	Specifies to enable the range component for output.
	False	Specifies to disable the range component for output.

Feature name	Description	
	Feature value	Description
QuickSetupConfidence Alternative: [ComponentSelector]{Confidence} and [ComponentEnable]{True} or {False}	Sets whether to enable for output the confidence component. This component stores confidence information for the range component, in Confidence8 pixel format. Each pixel of the confidence component indicates whether the value at the corresponding position in the range component was detected by the image sensor. If the peak was seen by the sensor, it has a confidence of 255, while a peak that was not seen by the sensor has a confidence of 0 and the corresponding position in the range component is set to Scan3dInvalidDataValue . This component is available when RegionSelector is set to Scan3dExtraction0 .	
	True	Specifies to enable the confidence component for output.
	False	Specifies to disable the confidence component for output.
QuickSetupReflectance Alternative: [ComponentSelector]{Reflectance} and [ComponentEnable]{True} or {False}	Sets whether to enable for output the reflectance component. This component stores a reflectance map in Mono8 pixel format. Each pixel of a reflectance map indicates that approximate intensity of the laser line at the point at which the peak was extracted. This component is available when RegionSelector is set to Scan3dExtraction0 .	
	True	Specifies to enable the reflectance component for output.
	False	Specifies to disable the reflectance component for output.
QuickSetupScatter Alternative: [ComponentSelector]{Scatter} and [ComponentEnable]{True} or {False}	Sets whether to enable for output the scatter component. This component stores a laser line scatter map, in Data8 pixel format. This corresponds to the approximate width of the laser line, measured in pixel units, in the column from which the peak was extracted. This component is available when RegionSelector is set to Scan3dExtraction0 .	
	True	Specifies to enable the scatter component for output.
	False	Specifies to disable the scatter component for output.
LightLaserBrightness	Sets the laser brightness, as a percentage of the total laser strength. This value can range from 1-100. By default, this feature is set to 50% .	

Trigger Control

The **Trigger Control** category groups features for quickly configuring a frame start and line start trigger. **Trigger Control** is a subcategory of the **Quick Setup Control** category.

Feature name	Description	
	Feature value	Description
TriggerSelector	Sets the type of trigger to configure.	
	FrameStart	Specifies to configure the frame start trigger. This trigger starts the capture of one frame (either a single-profile scan or multi-profile surface scan).
	LineStart	Specifies to configure the line (profile) trigger. This trigger starts the capture of one row of a frame (scan). This also corresponds to the trigger that starts the capture of the laser line image from which the profile is extracted.
	FrameActive	Specifies to configure the frame active trigger. This trigger controls the duration of one frame (either a single-profile scan or a multi-profile scan). Zebra Altiz 4200 will acquire profiles for as long as the frame active trigger signal is active. Use TriggerActivation to set the active level of the trigger signal. By default, it is set to LevelHigh ; Zebra Altiz 4200 starts the capture of a frame when the trigger signal rises and stops the capture when the signal falls.
TriggerSource [TriggerSelector]	Sets which source to use for triggering. By default, this feature is set to Line0 .	
	Line0	Specifies to use auxiliary line 0 as the trigger source.
	Line1	Specifies to use auxiliary line 1 as the trigger source.
	Line2	Specifies to use auxiliary line 2 as the trigger source.
	Line3	Specifies to use auxiliary line 3 as the trigger source.
	ObjectDetect	Specifies to use Zebra Altiz 4200 object detection as the trigger source. The Object Detect Control category, under Acquisition Control, provides features to set an object detection region. This setting is supported for a FrameStart or FrameActive trigger selector.
	Encoder0	Specifies to use encoder interface 0 output signal as the trigger source. Note that when using the Multi-Altiz Plugin, Encoder0 is set by default.
	Software	Specifies that the trigger source will be generated using the Software command.
Timer0End	Specifies to use the timer 0 end signal as the trigger source.	

Feature name	Description	
	Feature value	Description
TriggerSource [TriggerSelector] (Continued)...	Timer1End	Specifies to use the timer 1 end signal as the trigger source.
	Timer2End	Specifies to use the timer 2 end signal as the trigger source.
	Timer3End	Specifies to use the timer 3 end signal as the trigger source.
	Counter0End	Specifies to use the counter 0 end signal as the trigger source.
	Counter1End	Specifies to use the counter 1 end signal as the trigger source.
	Counter2End	Specifies to use the counter 2 end signal as the trigger source.
	Counter3End	Specifies to use the counter 3 end signal as the trigger source.
	LogicBlock0	Specifies to use the logic block 0 output signal as the trigger source.
	LogicBlock1	Specifies to use the logic block 1 output signal as the trigger source.
	LogicBlock2	Specifies to use the logic block 2 output signal as the trigger source.
	LogicBlock3	Specifies to use the logic block 3 output signal as the trigger source.
	SoftwareSignal0	Specifies to use software signal 0, generated using the SoftwareSignalPulse command, as the trigger source.
	SoftwareSignal1	Specifies to use software signal 1, generated using the SoftwareSignalPulse command, as the trigger source.
	SoftwareSignal2	Specifies to use software signal 2, generated using the SoftwareSignalPulse command, as the trigger source.
	SoftwareSignal3	Specifies to use software signal 3, generated using the SoftwareSignalPulse command, as the trigger source.
	Timer0Start	Specifies to use the timer 0 start signal as the trigger source.
	Timer1Start	Specifies to use the timer 1 start signal as the trigger source.
	Timer2Start	Specifies to use the timer 2 start signal as the trigger source.
	Timer3Start	Specifies to use the timer 3 start signal as the trigger source.
	Counter0Start	Specifies to use the counter 0 start signal as the trigger source.
	Counter1Start	Specifies to use the counter 1 start signal as the trigger source.
	Counter2Start	Specifies to use the counter 2 start signal as the trigger source.
Counter3Start	Specifies to use the counter 3 start signal as the trigger source.	
UserOutput0	Specifies to use the user output register bit 0 signal as the trigger source.	
UserOutput1	Specifies to use the user output register bit 1 signal as the trigger source.	

Feature name	Description	
	Feature value	Description
TriggerMode [TriggerSelector]	Sets whether the selected trigger is enabled or disabled. By default, this feature is set to Off .	
	On	Specifies to enable the trigger.
	Off	Specifies to disable the trigger.
TriggerActivation [TriggerSelector]	Sets the activation mode of the trigger. Use TriggerMode to enable the trigger. By default, this feature is set to RisingEdge .	
	RisingEdge	Specifies that the trigger is considered valid upon a rising edge (a low-to-high transition) of the source signal. This is not available if TriggerSelector is set to FrameActive .
	FallingEdge	Specifies that the trigger is considered valid upon a falling edge (a high-to-low transition) of the source signal. This is not available if TriggerSelector is set to FrameActive .
	AnyEdge	Specifies that the trigger is considered valid upon a rising edge or falling edge of the source signal. This is not available if TriggerSelector is set to FrameActive .
	LevelHigh	Specifies that the trigger is considered valid as long as the source signal is high.
	LevelLow	Specifies that the trigger is considered valid as long as the source signal is low.

Encoder Control

The **Encoder Control** category groups features that allow you to quickly setup or inquire about encoder interface 0. **Encoder Control** is a subcategory of the **Quick Setup Control** category.

Feature name	Description	
	Feature value	Description
EncoderResolution	Sets the distance between each encoder step (resolution), set in mm (per encoder step). By default, this is set to 0.1 .	
EncoderValue	Sets and returns the current value of the position counter of the encoder. Writing to EncoderValue is typically only used to set the start value of the position counter. By default, this feature is set to 1 .	
EncoderResetSource	Sets the signal that will reset the position counter of the encoder. By default, this feature is set to AcquisitionEnd .	
	Off	Specifies that the encoder (position counter) reset trigger is disabled.
	AcquisitionStart	Specifies to use the acquisition start signal as the reset signal.
	AcquisitionEnd	Specifies to use the acquisition end signal as the reset signal.
	SoftwareSignal0	Specifies to use software signal 0, generated using the SoftwareSignalPulse command, as the reset signal.
	SoftwareSignal1	Specifies to use software signal 1, generated using the SoftwareSignalPulse command, as the reset signal.
	SoftwareSignal2	Specifies to use software signal 2, generated using the SoftwareSignalPulse command, as the reset signal.
	SoftwareSignal3	Specifies to use software signal 3, generated using the SoftwareSignalPulse command, as the reset signal.
	Line0	Specifies to use auxiliary line 0 as the reset signal.
	Line1	Specifies to use auxiliary line 1 as the reset signal.
	Line2	Specifies to use auxiliary line 2 as the reset signal.
	Line3	Specifies to use auxiliary line 3 as the reset signal.
	Timer0End	Specifies to use the timer 0 end signal as the reset signal.
	Timer1End	Specifies to use the timer 1 end signal as the reset signal.
	Timer2End	Specifies to use the timer 2 end signal as the reset signal.
	Timer3End	Specifies to use the timer 3 end signal as the reset signal.
	Counter0End	Specifies to use the counter 0 end signal as the reset signal.
Counter1End	Specifies to use the counter 1 end signal as the reset signal.	
Counter2End	Specifies to use the counter 2 end signal as the reset signal.	
Counter3End	Specifies to use the counter 3 end signal as the reset signal.	
LogicBlock0	Specifies to use the logic block 0 output signal as the reset signal.	
LogicBlock1	Specifies to use the logic block 1 output signal as the reset signal.	

Feature name	Description	
	Feature value	Description
EncoderResetSource (Continued)...	LogicBlock2	Specifies to use the logic block 2 output signal as the reset signal.
	LogicBlock3	Specifies to use the logic block 3 output signal as the reset signal.
	UserOutput0	Specifies to use the user output register bit 0 signal as the reset signal.
	UserOutput1	Specifies to use the user output register bit 1 signal as the reset signal.
EncoderOutputMode	Sets the conditions for the encoder interface to generate a valid output signal. By default, this feature is set to PositionUp .	
	Off	Specifies that no output signal is generated.
	PositionUp	Specifies that output pulses are generated at any new position that is in the positive direction. If the encoder reverses, no output pulse is generated until it passes the same point at which the reversal began.
	DirectionUp	Specifies that output pulses are generated at any position that is in the positive direction. Any position in the negative direction is ignored.
	DirectionDown	Specifies that output pulses are generated at any position that is in the negative direction. Any position in the positive direction is ignored.
Motion	Specifies that output pulses are generated at all motion increments, regardless of direction.	
EncoderSourceA	Sets the auxiliary input line on which to receive signal A from the encoder. By default, this feature is set to Line0 .	
	Line0	Specifies to receive signal A on auxiliary line 0.
	Line1	Specifies to receive signal A on auxiliary line 1.
	Line2	Specifies to receive signal A on auxiliary line 2.
EncoderSourceB	Sets the auxiliary input line on which to receive signal B from the encoder.	
	Line0	Specifies to receive signal B on auxiliary line 0.
	Line1	Specifies to receive signal B on auxiliary line 1.
	Line2	Specifies to receive signal B on auxiliary line 2.
	Line3	Specifies to receive signal B on auxiliary line 3.

Object Detect Control

The **Object Detect Control** category groups features for configuring object detection, which is a trigger source that starts a grab when an object is detected within a region of the scan area. To use these features, first ensure that you have set **TriggerSource** to **ObjectDetect**. If the object is of a known length, you set **TriggerSelector** to **FrameStart**. In this case, the end of frame occurs when the end of **Scan3dVolumeLengthWorld** is reached. If the object is of a variable length, you set **TriggerSelector** to **FrameActive**. In this case, the end of frame occurs when a continuous gap along the Y-axis, as specified by **ObjectDetectGapY**, is encountered after the object, or **Scan3dVolumeLengthWorld** is reached. For more features related to Zebra Altiz 4200 object detection, see the *Object Detect Control* subsection of the *Acquisition Control* section later in this chapter.

Feature name	Description	
	Feature value	Description
ObjectDetectRegionStartX	Specifies the start of the object detection region, along the X-axis, in which to detect objects (in mm).	
ObjectDetectRegionEndX	Specifies the end of the object detection region, along the X-axis, in which to detect objects (in mm).	
ObjectDetectThresholdZ	Specifies the Z-threshold that delimits the region, along the Z-axis, in which to detect objects (in mm). Specify the Z-threshold relative to the Anchor coordinate system. An object must be between ObjectDetectThresholdZ and the near FoV to be detected. Note that if the Anchor coordinate system is moved after setting this feature, it will automatically be adjusted.	
ObjectDetectMinimumXYArea	Specifies the minimum area (in mm ²) that an object must have when projected on the XY-plane; otherwise, grabbed data is discarded if the object does not meet this minimum size. All peaks inside of the object detection region along the length of the object are used to calculate the area of an object, even if some peaks are not contiguous.	
ObjectDetectGapY	Specifies the length, along the Y-axis (in mm), of the contiguous gap that signifies the end of an object. An object is not considered complete until an area of this length is scanned without any peaks in the object detection region. This gap area is included in the transmitted data as part of the acquired frame. This feature is only used when TriggerSelector is set to FrameActive .	
ObjectDetectPrecedingProfiles	Specifies whether to keep up to a pre-established number of profiles that were taken prior to detecting an object, and transmit them as part of the frame.	
	True	Specifies that the transmitted data begins a set number of profiles before the detected object.
	False	Specifies that the transmitted data begins at the first profile that contains the detected object.

User Set Control

The **User Set Control** category groups features for quickly configuring a user set.

User Set Control is a subcategory of the **Quick Setup Control** category.

Feature name	Description	
	Feature value	Description
UserSetSelector	<p>Sets which user set to load, save, or configure. Typically, you load a user set and modify it to match your requirements. You then save all the current feature settings to one of the custom (writable) user sets (UserSet0, UserSet1, UserSet2, or UserSet3).</p> <p>Note that, when you load a user set, all current feature settings are overwritten. Make sure to take note of any required settings that you manually changed, before switching user sets.</p>	
	Profile	<p>Specifies the Profile user set. This user set optimally configures features for single-profile scans (for example, Scan3dVolumeCustomLengthWorld is set to 0). The Anchor coordinate system mode is set to ReferencePoint mode. The range component is enabled for output by default. This user set is not writable.</p>
	Surface	<p>Specifies the Surface user set. This user set optimally configures features for multi-profile surface scans (for example, Scan3dVolumeCustomLengthWorld is set to 100). The Anchor coordinate system mode is set to Height mode. The range component is enabled for output by default. This user set is not writable.</p>
	ProfileAndIntensity	<p>Specifies the ProfileAndIntensity user set. This user set optimally configures features for single-profile scans (for example, Scan3dVolumeCustomLengthWorld is set to 0). The Anchor coordinate system mode is set to ReferencePoint mode. The range and intensity components are enabled for output by default. This user set also has a lower frame (scan) rate than the Profile user set. This user set is not writable.</p>
	Intensity	<p>Specifies the Intensity user set. This user set is used to acquire and return the intensity component from the image sensor. The Anchor coordinate system mode is set to ReferencePoint mode. The intensity component is enabled for output by default. This user set also has a longer exposure time (10000 μsec) than the ProfileAndIntensity user set. This user set can be useful for positioning the Zebra Altiz 4200. This user set is not writable.</p>

Feature name	Description	
	Feature value	Description
UserSetSelector (Continued)...	Setup	Specifies the Setup user set. This user set is used to find optimal settings for your configuration. The Anchor coordinate system mode is set to ReferencePoint mode. This user set allows you to validate the setup and establish the required settings for proper peak extraction. The following components are enabled by default: [Source0][Region0]:Intensity [Source0][Scan3dExtraction0]: Peak0, Peak1, Scatter, Range This user set is not writable.
	UserSet0	Specifies UserSet0. This user set is writable and can be used to save customized settings. UserSet0 is initialized with the Profile user set settings.
	UserSet1	Specifies UserSet1. This user set is writable and can be used to save customized settings. UserSet1 is initialized with the Profile user set settings.
	UserSet2	Specifies UserSet2. This user set is writable and can be used to save customized settings. UserSet2 is initialized with the Profile user set settings.
	UserSet3	Specifies UserSet3. This user set is writable and can be used to save customized settings. UserSet3 is initialized with the Profile user set settings.
UserSetDescription [UserSetSelector]	Sets the description of the user set.	
UserSetLoad [UserSetSelector]	Loads the user set specified by UserSetSelector . Note that, when you load a new user set, all current feature settings are overwritten. Make sure to take note of any required settings that you manually changed, before switching user sets.	
UserSetSave [UserSetSelector]	Saves the current values of all features to the user set specified by UserSetSelector , in non-volatile memory of Zebra Altix 4200.	
UserSetDefault	Sets which user set to load and make active by default when Zebra Altix 4200 is reset. Note that changing this feature has no effect on the default of UserSetSelector . By default, this feature is set to Profile .	
	Profile	Specifies to use the Profile user set by default.
	Surface	Specifies to use the Surface user set by default.
	ProfileAndIntensity	Specifies to use the ProfileAndIntensity user set by default.
	Intensity	Specifies to use the Intensity user set by default.
	Setup	Specifies to use the Setup user set by default.
	UserSet0	Specifies to use UserSet0 by default.
	UserSet1	Specifies to use UserSet1 by default.
UserSet2	Specifies to use UserSet2 by default.	
UserSet3	Specifies to use UserSet3 by default.	

Scan 3D Control

The **Scan 3D Control** category groups features specifically related to the acquisition of 3D data. For information on these topics, see *Chapter 4: Understanding and setting the features of your Zebra Altiz 4200*.

Feature name	Description	
	Feature value	Description
Scan3dUsageMode	Returns the scan mode that Zebra Altiz 4200 is currently set to use. When features that affect the mode are modified (such as Scan3dVolumeLengthWorld), this feature will automatically update. This feature is useful to know if Zebra Altiz 4200 is set to perform a single-profile scan or a multi-profile surface scan. To establish the format in which the data is transmitted (depth map or point cloud), see Scan3dOutputMode instead. This feature is read only.	
	Profile	Specifies Zebra Altiz 4200 will output a single-profile scan.
	ProfileAndIntensity	Specifies Zebra Altiz 4200 will output a single-profile scan, and the laser line image from which the 3D data was extracted. The latter will be transmitted in the intensity component of the scan.
	Intensity	Specifies Zebra Altiz 4200 will output the intensity component of the image sensor.
	Surface	Specifies Zebra Altiz 4200 will output a multi-profile surface scan.
Scan3dTriggerSourceMode	Returns the mode in which rows (profiles) of the scan are captured. This feature is dependent on how you set the TriggerMode and TriggerSource features of the LineStart trigger. This feature is read only.	
	Continuous	Specifies the LineStart trigger is disabled (TriggerMode is set to Off); rows (profiles) are grabbed continuously at a constant line (profile) rate (AcquisitionLineRate).
	Trigger	Specifies Zebra Altiz 4200 will start the acquisition of each row (profile) upon the reception of a line (profile) trigger and the source of the line trigger is not an encoder.
	Encoder	Specifies Zebra Altiz 4200 will start the acquisition of each row (profile) upon the reception of a line (profile) trigger and the source of the line trigger is an encoder.

Feature name	Description	
	Feature value	Description
Scan3dMotionInputType	<p>Sets which constraint is known when parameterizing Zebra Altiz 4200 to perform a multi-profile surface scan. The value of the known constraint and the current value of AcquisitionLineRate are used to automatically calculate the unknown constraint; by default, AcquisitionLineRate is set to the maximum possible acquisition line (profile) rate.</p> <p>For more information, see the <i>Specifying displacement when using a line (profile) trigger</i> section, in <i>Chapter 4: Understanding and setting the features of your Zebra Altiz 4200</i>. By default, Scan3dMotionInputType is set to Step.</p>	
	Step	<p>Specifies the scan step is provided and speed will be automatically calculated. When Scan3dMotionInputType is set to Step. If not using a line (profile) trigger, you will need to manually set your conveyor (or other device) to move exactly at the speed that is calculated for you (Scan3dMotionSpeedWorld). If using a line (profile) trigger, the maximum speed at which the conveyor should move is Scan3dMotionSpeedMaxWorld.</p>
	Speed	<p>Specifies that the motion speed is provided and the scan step will be automatically calculated. When using a line (profile) trigger and TriggerSource is not set to Encoder0, this setting is not supported.</p>
Scan3dMotionStepWorld	<p>Sets the scan step (displacement between two consecutive profiles) along the direction of motion, in mm. You must set this feature when you set Scan3dMotionInputType to Step. This feature is not available when Scan3dMotionInputType is set to Speed. By default, this feature is set to 1.</p>	
Scan3dMotionEffectiveStepWorld	<p>Returns the effective scan step (the scan step that will actually be used), in mm. The scan step is automatically calculated when Scan3dMotionInputType is set to Speed. When Scan3dMotionInputType is set to Step, Scan3dMotionEffectiveStepWorld will be the closest possible match to Scan3dMotionStepWorld. There might be a discrepancy between the two (for example, as a result of the encoder resolution).</p>	
Scan3dMotionSpeedWorld	<p>Sets or only returns the motion speed in mm/sec.</p> <p>When Scan3dMotionInputType is set to Speed, you must set this feature to the speed of the conveyor (or other device), or if using an encoder, to the maximum speed of the conveyor. In Speed mode, this feature is only applicable when Scan3dUsageMode is set to Surface and, if using a line (profile) trigger, its source is an encoder.</p> <p>When Scan3dMotionInputType is set to Step, this feature is read only and returns the automatically calculated speed at which your conveyor must move if you are not using a line (profile) trigger. When using a line (profile) trigger, see Scan3dMotionSpeedMaxWorld for the maximum speed at which your conveyor should move. In Step mode, Scan3dMotionSpeedWorld is only visible when Scan3dUsageMode is set to Surface and you are not using a line (profile) trigger.</p> <p>Regardless of whether specifying the speed or having it calculated, if you are not using a line (profile) trigger, set your conveyor (or other device) to move exactly at this speed; otherwise, you will acquire the object at the wrong aspect ratio. When using a line (profile) trigger, see Scan3dMotionSpeedMaxWorld.</p> <p>For more information, see the <i>Modifying scan area, scan length, and scan step</i> section, in <i>Chapter 4: Understanding and setting the features of your Zebra Altiz 4200</i>.</p>	

Feature name	Description	
	Feature value	Description
Scan3dMotionSpeedMaxWorld	Returns the maximum speed at which your conveyor should move, given the values of Scan3dStepMotionEffectiveStepWorld and AcquisitionsLineRateMax . Note that when Scan3dMotionInputType is set to Speed , Scan3dMotionSpeedMaxWorld might not be exactly equal to the value that you have set for Scan3dMotionSpeedWorld (because of the encoder divider which quantizes the possible values). This feature is only available when using a line (profile) trigger. For information on how speed and step relate, see the <i>Specifying displacement when using a line (profile) trigger</i> section, in <i>Chapter 4: Understanding and setting the features of your Zebra Altiz 4200</i> .	
Scan3dMotionDirection	Sets the direction of motion relative to the Y-axis of the Anchor coordinate system. If not set properly, your data will be a mirrored representation of your scanned object. Note that the direction of the Y-axis depends on how you set Scan3dCoordinateSystemAnchorMode . Note that, when using the Multi-Altiz Plugin, the value set on the main Zebra Altiz 4200 unit copies over to secondary Zebra Altiz 4200 units automatically.	
	Same	Specifies that the direction of motion is the same as the current direction of the Y-axis.
	Reverse	Specifies that the direction of motion is the opposite of the current direction of the Y-axis.
Scan3dMotionPitch	Sets the rotation around the X-axis of the Zebra Altiz 4200 3D sensor in the Anchor coordinate system. A positive value denotes that the front of the Zebra Altiz 4200 3D sensor (where the ground screw is located) is tilted upwards, and a negative value denotes that the front of the Zebra Altiz 4200 3D sensor is tilted downwards. Scan3dMotionPitch is used to correct misalignment when the direction of motion is not perfectly parallel to the length of the Zebra Altiz 4200 body (the top and bottom surfaces of Zebra Altiz 4200 are not parallel with the surface of the conveyor). You can only set this value in degrees.	
Scan3dMotionYaw	Sets the rotation around the Z-axis of the Zebra Altiz 4200 3D sensor in the Anchor coordinate system. A positive value denotes that the Zebra Altiz 4200 3D sensor is rotated to the right when looking from behind the sensor of a top-mounted Zebra Altiz 4200 3D sensor. A negative value denotes the Zebra Altiz 4200 3D sensor is rotated to the left when looking from behind the sensor of a top-mounted Zebra Altiz 4200 3D sensor. Scan3dMotionYaw is used to correct misalignment when the laser line (laser plane) is not perfectly perpendicular to the direction of motion. You can only set this value in degrees.	
Scan3dDistanceUnit	Returns the units that Scan3dOutputMode will use. The only available value is mm.	
Scan3dCoordinateSystem	Returns the coordinate system used by Zebra Altiz 4200. The only coordinate system available is Cartesian (XYZ coordinates). This feature is read only.	

Feature name	Description	
	Feature value	Description
Scan3dOutputMode	Sets in which mode to output 3D data. For all supported modes, displacement (scan step) is assumed to be constant between profiles. By default, this feature is set to RectifiedC (depth map).	
	CalibratedABC_Grid	Specifies to output 3D data in a point cloud format. This will convert the selected peaks to explicit real-world XYZ-coordinates, whereby the X, Y, and Z coordinates are stored in separate bands of the range component as 32-bit floating point (32F) values.
	RectifiedC	Specifies to output 3D data in depth map format. This will convert the selected peaks to real world depths, with implied X and Y-coordinates based on the grid position; the range component only stores the Z-coordinates, encoded as 16-bit unsigned integer values and an established scale.
Scan3dCoordinateSystemAnchorMode	Sets the Anchor coordinate system mode. The mode establishes the position and orientation of the Anchor coordinate system. For information on where these positions are in relation to Zebra Altiz 4200, see <i>Anchor coordinate system modes</i> section, in <i>Chapter 4: Understanding and setting the features of your Zebra Altiz 4200</i> . By default, this feature is set to ReferencePoint .	
	Distance	Specifies that the origin of the Anchor coordinate system, when facing the connectors of Zebra Altiz 4200, is at the near FoV aligned with the left edge of the far FoV. In this mode, the orientation matches the Y-Z reference mark (on the body of Zebra Altiz 4200). In this mode, all X and Z-coordinates are positive.
	Height	Specifies that the origin of the Anchor coordinate system, when facing the connectors of Zebra Altiz 4200, is to the left edge of the far FoV, and at the beginning of the far FoV. In this mode, the orientation of the Z-axis points towards the body of Zebra Altiz 4200, with the Y-axis pointing in the opposite direction from the Y-Z reference mark. In this mode, all X and Z-coordinates are positive.
	ReferencePoint	Specifies that the origin of the Anchor coordinate system is approximately located at the Y-Z reference mark, with the X-coordinate centered along the width of the body. The orientation matches the Y-Z reference mark. In this mode, X-coordinates can be positive or negative, and all the Z-coordinates are positive.
Scan3dCoordinateSystemReference	Sets relative to which coordinate system to output coordinates, when outputting a point cloud. By default, this feature is set to Anchor .	
	Anchor	Specifies to use the Anchor coordinate system.
	Transformed	Specifies to use the Transformed coordinate system. In this coordinate system, Scan3dOutputMode should only be set to CalibratedABC_Grid (a point cloud).
ResolutionX	Sets the resolution required along the X-axis between two adjacent points, in mm, along the X-axis. The possible range for ResolutionX increases as your scan area approaches the near FoV. To set the scan area, set Scan3dVolumeZMode to Configurable and adjust both Scan3dVolumeOffsetZWorld and Scan3dVolumeSizeZWorld appropriately. If the required resolution cannot be achieved, the closest supported resolution will be used, as returned by EffectiveResolutionX . For more information, see the <i>Adjusting the resolution along the X-axis</i> section, in <i>Chapter 4: Understanding and setting the features of your Zebra Altiz 4200</i> .	

Feature name	Description	
	Feature value	Description
EffectiveResolutionX	Returns the actual distance used between two adjacent points, in mm, along the X-axis. This is the closest supported resolution to the one specified using ResolutionX . This can change as you modify the scan area. For more information, see <i>Adjusting the resolution along the X-axis</i> section, in <i>Chapter 4: Understanding and setting the features of your Zebra Altiz 4200</i> .	
Scan3dCoordinateSelector	Sets the particular coordinates about which to inquire their offset or scale.	
	CoordinateA	Specifies to inquire about the X-coordinates.
	CoordinateB	Specifies to inquire about the Y-coordinates.
	CoordinateC	Specifies to inquire about the Z-coordinates.
Scan3dInvalidDataFlag [Scan3dCoordinateSelector]	Sets whether to identify missing data/points in the range component. Missing data/points will be set to the invalid data value (Scan3dInvalidDataValue). The only available value for this feature is True .	
Scan3dInvalidDataValue [Scan3dCoordinateSelector]	Sets the invalid data value. This value will be used in all bands of the range component for missing data/points, even if outputting a confidence component. You should always use a predetermined invalid value. For 16U data types, a floating point value is cast to 16U. By default, this feature is set to 0 .	
Scan3dCoordinateScale [Scan3dCoordinateSelector]	Returns the scale used to convert from relative coordinates to real-world coordinates. If Scan3dOutputMode is set to CalibratedABC_Grid , the scale is 1.0. This value is fixed depending on your Zebra Altiz 4200.	
Scan3dCoordinateOffset [Scan3dCoordinateSelector]	Returns the offset used to convert from relative coordinates to real world coordinates, in mm. If Scan3dOutputMode is set to CalibratedABC_Grid , the offset is 0.0. This value is fixed depending your Zebra Altiz 4200.	
Scan3dAxisMin [Scan3dCoordinateSelector]	Returns the minimum transmitted coordinate value of the selected coordinate. This feature is available when Scan3dOutputMode is set to CalibratedABC_Grid , or when Scan3dOutputMode is set to RectifiedC and Scan3dCoordinateSelector is set to CoordinateC .	
Scan3dAxisMax [Scan3dCoordinateSelector]	Returns the maximum transmitted coordinate value of the selected coordinate. This feature is available when Scan3dOutputMode is set to CalibratedABC_Grid , or when Scan3dOutputMode is set to RectifiedC and Scan3dCoordinateSelector is set to CoordinateC .	
Scan3dCoordinateTransformSelector	Sets which parameter of the transformation that expresses the Transformed coordinate system, to set or inquire about; the transformation is relative to the Anchor coordinate system.	
	RotationX	Specifies the rotation around the X-axis.
	RotationY	Specifies the rotation around the Y-axis.
	RotationZ	Specifies the rotation around the Z-axis.
	TranslationX	Specifies the translation along the X-axis.
	TranslationY	Specifies the translation along the Y-axis.
	TranslationZ	Specifies the translation along the Z-axis.
Scan3dTransformValue [Scan3dCoordinateTransformSelector]	Sets the value to use for the selected transformation parameter. For translations, this value corresponds to mm. For rotations, this value corresponds to degrees. By default, this feature is set to 0 .	

Feature name	Description	
	Feature value	Description
Scan3dCoordinateReferenceSelector	Sets which parameter of the transformation that expresses the Reference coordinate system, to set or inquire about; the transformation is relative to the Anchor coordinate system.	
	RotationX	Specifies the rotation around the X-axis.
	RotationY	Specifies the rotation around the Y-axis.
	RotationZ	Specifies the rotation around the Z-axis.
	TranslationX	Specifies the translation along the X-axis.
	TranslationY	Specifies the translation along the Y-axis.
TranslationZ	Specifies the translation along the Z-axis.	
Scan3dCoordinateReferenceValue [Scan3dCoordinateReferenceSelector]	Sets the value to use for the selected transformation parameter. For translations, this value corresponds to mm. For rotations, this value corresponds to degrees. By default, this feature is set to 0 .	

Volume Control

The **Volume Control** category groups features related to scan area, scan length, and scan step. **Volume Control** is a subcategory of the **Scan 3D Control** category. For information, see *Modifying scan area, scan length, and scan step* section, in *Chapter 4: Understanding and setting the features of your Zebra Altiz 4200*.

Feature name	Description	
	Feature value	Description
Scan3dVolumeDefinitionMode	Sets the units that define the entire surface to scan (scan area, scan length, and scan step). By default, this feature is set to World .	
	Note that, when Scan3dVolumeDefinitionMode is set to Raw , both Height and OffsetY become writable.	
	World	Specifies that the surface to scan is defined in world units.
	Raw	Specifies that the surface to scan is defined in pixels and number of profiles.
Scan3dVolumeLengthWorld	Sets the scan length (length of the surface to scan) along the direction of motion, in mm (world units). Note, you should include the distance from the start of the scan (frame trigger) until the end of the object. To only acquire a single profile, set this to 0. When this value is changed from 0, Scan3dUsageMode updates to Surface . Changes to Scan3dVolumeLengthWorld can have an effect on AcquisitionFrameRateMax . This feature is available if Scan3dVolumeDefinitionMode is set to World and the intensity component is not enabled for output. Note that, when using the Multi-Altiz Plugin, the value set on the main Zebra Altiz 4200 unit copies over to secondary Zebra Altiz 4200 units automatically. By default, this feature is set to 0 (single-profile scan).	
Scan3dVolumeEffectiveLengthWorld	Returns the length of the effective scan length (length of the surface to scan) along the direction of motion, in mm (world units). The value generated for Scan3dVolumeEffectiveLengthWorld is calculated as a multiple of Scan3dMotionEffectiveStepWorld , and unless the step value divides perfectly into Scan3dVolumeLengthWorld , there will be a slight discrepancy between Scan3dVolumeEffectiveLengthWorld and Scan3dVolumeLengthWorld . This feature is read only.	

Feature name	Description	
	Feature value	Description
Scan3dVolumeZMode	Sets whether to use the full scan area, or a custom scan area. Scan3dVolumeZMode feature is only available if Scan3dVolumeDefinitionMode is set to World . Note that, when using the Multi-Altiz Plugin, the value set on the main Zebra Altiz 4200 unit copies over to secondary Zebra Altiz 4200 units automatically. By default, this feature is set to Full .	
	Full	Specifies to use the full scan area available given your Zebra Altiz 4200 model (that is, the entire region of your available FoV). A profile can have all possible heights in the available Z-range.
	Configurable	Specifies to use a custom size scan area, smaller than your available FoV. Note that you can only change the scan area along the Z-axis; the size along the X-axis is always set to the maximum X of your model type.
Scan3dVolumeSizeZWorld	Sets the size of the scan area along the Z-axis, in mm (world units). Changes to this feature can have an effect on AcquisitionLineRateMax . Reducing the scan area along the Z-axis reduces the grabbed laser line image size. This increases the maximum possible acquisition line rate (rate at which profiles are taken); this is useful if you need to increase scan speed or resolution. Ideally, the scan area should only correspond to your area of interest (for example, only the top of your object). Scan3dVolumeSizeZWorld is only available if Scan3dVolumeDefinitionMode is set to World and Scan3dVolumeZMode is set to Configurable .	
Scan3dVolumeOffsetZWorld	Sets an offset for the custom scan area, along the Z-axis of your available range, in mm (world units). Specify the Z-offset from the origin of the Anchor coordinate system. This allows you to shift the custom scan area higher or lower along the Z-axis. Scan3dVolumeOffsetZWorld is only available if Scan3dVolumeDefinitionMode is set to World and Scan3dVolumeZMode is set to Configurable . Changing Scan3dVolumeOffsetZWorld can also have an effect on AcquisitionLineRateMax .	
Scan3dEffectiveSizeZWorld	Returns the total size of the measurement range along the Z-axis, in mm (world units). Scan3dEffectiveSizeZWorld can either be a custom value that you have set with Scan3dVolumeSizeZWorld , or the default value for Scan3dVolumeSizeZWorld based on the model of Zebra Altiz 4200. This feature is read-only.	
Scan3dEffectiveMinZWorld	Returns the start of the measurement range along the Z-axis in mm (world units). This feature is read-only.	
Scan3dEffectiveCenterZWorld	Returns the center of the measurement range along the Z-axis in mm (world units). This feature is read-only.	
Scan3dEffectiveMaxZWorld	Returns the end of the measurement range along the Z-axis in mm (world units). This feature is read-only.	

Peak Extraction and Selection Control

The **Peak Extraction and Selection Control** category groups features related to peak extraction. **Peak Extraction and Selection Control** is a subcategory of the **Scan 3D Control** category. For information, see *Peak processing* section, in *Chapter 4: Understanding and setting the features of your Zebra AltiZ 4200*.

Feature name	Description	
	Feature value	Description
Scan3dPeakContrastMin	Sets the minimum allowable difference between the intensity of the local background and that of the peak. Set this value between 4-255 inclusive. Note that, when using the Multi-AltiZ Plugin, the value set on the main Zebra AltiZ 4200 unit copies over to secondary Zebra AltiZ 4200 units automatically. By default, Scan3dPeakContrastMin is set to 100.	
Scan3dSourcePeakMedianFilterSize	Sets the size of the median filter applied to each row, in pixels. The filter is applied before the peak extraction process, before processing the columns. This can reduce the effect of speckle noise of the laser. By default, this feature is set to Size3 .	
	NoFilter	Specifies not to apply a filter.
	Size3	Specifies a median filter size of 3 pixels.
	Size5	Specifies a median filter size of 5 pixels.
Scan3dPeakReflectanceWindowSize	Sets the size of the vertical window used to calculate the average intensity of the peak, in pixels. Note that, when using the Multi-AltiZ Plugin, the value set on the main Zebra AltiZ 4200 unit copies over to secondary Zebra AltiZ 4200 units automatically. By default, this feature is set to 10 pixels.	
Scan3dPeakSelectionMode	Sets the selection mode used to determine which peak is accepted when there is more than one peak in a column. Note that, when using the Multi-AltiZ Plugin, the value set on the main Zebra AltiZ 4200 unit copies over to secondary Zebra AltiZ 4200 units automatically.	
	Brightest	Specifies to select the brightest peak in the column. The brightest peak is determined by the average brightness among peaks found across <i>Scan3dPeakReflectanceWindowSize</i> .
	Closest	Specifies to select the closest peak in the column, with respect to the selected <i>Scan3dCoordinateSystemAnchorMode</i> .
	Farthest	Specifies to select the farthest peak in the column, with respect to the selected <i>Scan3dCoordinateSystemAnchorMode</i> .
Scan3dPeakWidthMin	Sets the minimum allowable width of a peak, in pixels. By default, this feature is set to 1 pixel.	
Scan3dPeakWidthMax	Sets the maximum allowable width of a peak, in pixels. By default, this feature is set to 31 pixels.	

Device Control

The **Device Control** category groups features that provide general information about Zebra Altiz 4200. These features are mainly used to identify your Zebra Altiz 4200 during the enumeration process. All of the following features, except for **DeviceUserId** and **DeviceUserData** are read only.

Feature name	Description
DeviceType	Returns the device type. For Zebra Altiz 4200, this feature returns <i>Transmitter</i> .
DeviceScanType	Returns the scan type. For Zebra Altiz 4200, this feature returns <i>Linescan3D</i> .
DeviceVendorName	Returns the name of the manufacturer. For Zebra Altiz 4200, this feature returns <i>Zebra</i> .
DeviceModelName	Returns the name of the device model. For Zebra Altiz 4200, this feature returns <i>Zebra Altiz 4200</i> .
DeviceManufacturerInfo	Returns manufacturer information of Zebra Altiz 4200.
DeviceDescription	Returns a human readable description of Zebra Altiz 4200.
DeviceVersion	Returns the version of Zebra Altiz 4200.
DeviceFirmwareVersion	Returns the firmware version of Zebra Altiz 4200.
DeviceSerialNumber	Returns the serial number of Zebra Altiz 4200.
DeviceUserID	Changes the user ID of Zebra Altiz 4200. You can set this feature to any null terminated string.
DeviceUserData	Sets a persistent string of data on the device, typically used to identify something unique about the device (for example, its physical location or other information that might be useful to the user). The maximum length for the string of data is 512 bytes.
DeviceSFNCVersionMajor	Returns the major version of the Standard Naming Convention that was used to create Zebra Altiz 4200's XML file.
DeviceSFNCVersionMinor	Returns the minor version of the Standard Naming Convention that was used to create Zebra Altiz 4200's XML file.
DeviceSFNCVersionSubMinor	Returns the subminor version of the Standard Naming Convention that was used to create Zebra Altiz 4200's XML file.
DeviceTLType	Returns the transport layer type. For Zebra Altiz 4200, this feature returns <i>GigEVision</i> .
DeviceTLVersionMajor	Returns the major version number of the transport layer of Zebra Altiz 4200.
DeviceTLVersionMinor	Returns the minor version number of the transport layer of Zebra Altiz 4200.
DeviceTLVersionSubMinor	Returns the subminor version number of the transport layer of Zebra Altiz 4200.
DeviceLinkSelector	Sets which link of the device to control.
DeviceLinkSpeed [DeviceLinkSelector]	Returns the speed of transmission for the specified link.
DevicePowerSource	Returns the power source that is currently being used by Zebra Altiz 4200 (for example External, PoE, or PoE+). When multiple power sources are detected, auxiliary power takes precedence.
DeviceReset	Resets Zebra Altiz 4200 to its power up state. After reset, Zebra Altiz 4200 must be re-discovered.
DeviceTemperatureSelector	Sets the location within the device from which to return the temperature.

Feature name	Description
LaserTemperature [DeviceTemperatureSelect]	Returns the temperature of the laser, in degrees Celsius.
DeviceClockFrequency	Returns the clock frequency of the selected clock, in Hz.
TimeStampReset	Resets the current value of the Zebra Altiz 4200 timestamp counter.
TimeStampLatch	Latches the current timestamp counter value into TimeStampLatchValue .
TimeStampLatchValue	Returns the latched value of the timestamp counter. Values are returned in nsec.

User Set Control

The **User Set Control** category groups features for configuring Zebra Altiz 4200 with factory or user-defined setting (user sets). For information on the user sets available to Zebra Altiz 4200, see *Zebra Altiz 4200 workflow* section, in *Chapter 4: Understanding and setting the features of your Zebra Altiz 4200*.

Feature name	Description	
	Feature value	Description
UserSetSelector	<p>Sets which user set to load, save, or configure. Typically, you load a user set and modify it to match your requirements. You then save all the current feature settings to one of the custom (writable) user sets (UserSet0, UserSet1, UserSet2, or UserSet3).</p> <p>Note that, when you load a user set, all current feature settings are overwritten. Make sure to take note of any required settings that you manually changed, before switching user sets.</p>	
	Profile	<p>Specifies the Profile user set. This user set optimally configures features for single-profile scans (for example, Scan3dVolumeCustomLengthWorld is set to 0). The Anchor coordinate system mode is set to ReferencePoint mode. The range component is enabled for output by default. This user set is not writable.</p>
	Surface	<p>Specifies the Surface user set. This user set optimally configures features for multi-profile surface scans (for example, Scan3dVolumeCustomLengthWorld is set to 100). The Anchor coordinate system mode is set to Height mode. The range component is enabled for output by default. This user set is not writable.</p>
	Intensity	<p>Specifies the Intensity user set. This user set is used to acquire and return the intensity component from the image sensor (Source 0). The Anchor coordinate system mode is set to ReferencePoint mode. The intensity component is enabled for output by default. This user set also has a longer exposure time (10000 μsec) than the ProfileAndIntensity user set. This user set can be useful for positioning the Zebra Altiz 4200. This user set is not writable.</p>

Feature name	Description	
	Feature value	Description
UserSetSelector (Continued)...	ProfileAndIntensity	Specifies the ProfileAndIntensity user set. This user set optimally configures features for single-profile scans (for example, Scan3dVolumeCustomLengthWorld is set to 0). The Anchor coordinate system mode is set to ReferencePoint mode. The range and intensity components are enabled for output by default. This user set also has a lower frame (scan) rate than the Profile user set. This user set is not writable.
	Setup	Specifies the Setup user set. This user set is used to find optimal settings for your configuration. The Anchor coordinate system mode is set to ReferencePoint mode. This user set allows you to validate the setup and establish the required settings for proper peak extraction. The following components are enabled by default: [Source0][Region0]:Intensity [Source0][Scan3dExtraction0]: Peak0, Peak1, Scatter, Range This user set is not writable.
	UserSet0	Specifies UserSet0. This user set is writable and can be used to save customized settings. UserSet0 is initialized with the Profile user set settings.
	UserSet1	Specifies UserSet1. This user set is writable and can be used to save customized settings. UserSet1 is initialized with the Profile user set settings.
	UserSet2	Specifies UserSet2. This user set is writable and can be used to save customized settings. UserSet2 is initialized with the Profile user set settings.
	UserSet3	Specifies UserSet3. This user set is writable and can be used to save customized settings. UserSet3 is initialized with the Profile user set settings.
	UserSetDescription [UserSetSelector]	Sets the description of the user set.
UserSetLoad [UserSetSelector]	Loads the user set specified by UserSetSelector . Note that, when you load a new user set, all current feature settings are overwritten. Make sure to take note of any required settings that you manually changed, before switching user sets.	
UserSetSave [UserSetSelector]	Saves the current values of all features to the user set specified by UserSetSelector , in non-volatile memory of Zebra Altiz 4200.	

Feature name	Description	
	Feature value	Description
UserSetDefault	Sets which user set to load and make active by default when Zebra Altiz 4200 is reset. Note that changing this feature has no effect on the default of UserSetSelector . By default, this feature is set to Profile .	
	Profile	Specifies to use the Profile user set by default.
	Surface	Specifies to use the Surface user set by default.
	ProfileAndIntensity	Specifies to use the ProfileAndIntensity user set by default.
	Intensity	Specifies to use the Intensity user set by default.
	Setup	Specifies to use the Setup user set by default.
	UserSet0	Specifies to use UserSet0 by default.
	UserSet1	Specifies to use UserSet1 by default.
	UserSet2	Specifies to use UserSet2 by default.
UserSet3	Specifies to use UserSet3 by default.	

Image Format Control

The **Image Format Control** category groups features that control the components and format of the transmitted data. This includes which components are transmitted and their format. For information, see *Zebra AltiZ 4200 workflow* section, in *Chapter 4: Understanding and setting the features of your Zebra AltiZ 4200*.

Feature name	Description	
	Feature value	Description
RegionSelector	Sets which region of the processing pipelines to control. For more information, see <i>Zebra AltiZ 4200 workflow</i> section, in <i>Chapter 4: Understanding and setting the features of your Zebra AltiZ 4200</i> .	
	Region0	Specifies to control Region0. This region applies to the laser line image and the intensity component of the processing pipeline.
	Scan3dExtraction0	Specifies to control Scan3dExtraction0. This region applies to the point cloud or depth map that is output from the processing pipeline.
RegionMode [RegionSelector]	Sets whether the selected region is active and streaming. By default, this feature is set to On .	
	On	Specifies the selected region is active.
	Off	Specifies the selected region is not active.
RegionIDValue [RegionSelector]	Returns an identifier value that corresponds to the selected region. Region0 returns 0 and Scan3dExtraction returns 10 . This feature is read only.	
GroupIDValue [RegionSelector]	Returns an identifier value that corresponds to the selected group of components. This feature is read only.	
Width [RegionSelector]	Returns the width of all returned components, which corresponds to a value along the X-axis. This value is returned in pixels, and cannot be changed. By default, this is fixed to the width of the image sensor. This feature is read only.	
Height [RegionSelector]	<p>Returns the height of the output components from the selected region. This value is returned in pixels.</p> <p>If RegionSelector is set to Region0, this feature returns the height of your intensity component. Be aware that changing the scan area along the Z-axis (size along the Z-axis, controlled using Scan3dVolumeSizeZWorld0) also changes the ROI of Region0, which can possibly update the value for OffsetY.</p> <p>If RegionSelector is set to Scan3dExtraction0, this feature returns the height of all other components, and corresponds to the number of profiles taken along the direction of motion of the scan.</p> <p>This feature is read only.</p>	
OffsetX [RegionSelector]	Returns the offset from the origin for the selected region, along the X-axis in pixels. OffsetX is always 0 . This feature is read only.	

Feature name	Description	
	Feature value	Description
OffsetY [RegionSelector]	Returns the offset from the origin for the selected region, along the Y-axis. This is returned in pixels. If RegionSelector is set to Region0 , this will define the offset along the Y-axis of the laser line image, which is transmitted in the intensity component. If RegionSelector is set to Scan3dExtraction0 , this returns 0. Be aware that changing the scan area changes the ROI of Region0 , which can possibly update the value for OffsetY . This feature is read only.	
ComponentSelector [RegionSelector]	Sets which component to control. Components from the processing pipeline are transmitted in Group 0, components from the secondary processing pipeline are transmitted in Group 1, and components from the 3D reconstruction fusion/alternating pipeline are transmitted in Group 2.	
	Intensity	Specifies the intensity component. This component stores a grayscale image of light in the visible spectrum (filtered), in Mono8 pixel format. This is the image of the laser line. This component is only available when outputting a single-profile scan (that is, when Scan3dVolumeLengthWorld is set to 0) and RegionSelector is set to Region0 .
	Range	Specifies the range component. This component stores 3D distance or position information. If Scan3dOutputMode is set to RectifiedC , the range component is stored in Coord3D_C16 pixel format. If Scan3dOutputMode is set to CalibratedABC_Grid , the range component is stored in Coord3D_ABC32f_Planar pixel format. This component is available when RegionSelector is set to Scan3dExtraction0 .
	Reflectance	Specifies the reflectance component. This component stores a reflectance map in Mono8 pixel format. Each pixel of a reflectance map indicates that approximate intensity of the laser line at the point at which the peak was extracted. This component is available when RegionSelector is set to Scan3dExtraction0 .
	Confidence	Specifies the confidence component. This component stores confidence information for the range component, in Confidence8 pixel format. Each pixel of the confidence component indicates whether the value at the corresponding position in the range component was detected by the image sensor. If the peak was seen by the sensor, it has a confidence of 255, while a peak that was not seen by the sensor has a confidence of 0 and the corresponding position in the range component is set to Scan3dInvalidDataValue . This component is available when RegionSelector is set to Scan3dExtraction0 .

Feature name	Description	
	Feature value	Description
ComponentSelector [RegionSelector] (Continued)...	PeakSource	Specifies the PeakSource component. This component stores a Data8 bitfield that indicates from which of the two extracted peak(s) (<i>Peak 0</i> and <i>Peak 1</i> components), the depth/position stored in the range component originated. Registered peaks are identified by bits 0 and 1. This component has the GenICam custom component type 0 (that is, 0xFF00). This component is available when RegionSelector is set to Scan3dExtraction0 .
	Scatter	Specifies the scatter component. This component stores a laser line scatter map, in Data8 pixel format. This corresponds to the approximate width of the laser line, measured in pixel units, in the column from which the peak was extracted. This component is available when RegionSelector is set to Scan3dExtraction0 .
	Peak0	Specifies the Peak0 component. This component stores the Y-coordinates of the extracted peaks, in the pixel coordinate system of the image of the laser line; this is stored in Data16 pixel format. This is useful to display the locations of the extracted peaks on top of the laser line image (intensity component of a single-profile scan). Values are encoded with 5 bits of fixed-point precision. The value 65535 denotes the absence of a peak. This component has the GenICam custom component type 1 (that is, 0xFF01). This component is available when RegionSelector is set to Scan3dExtraction0 .
	Peak1	Specifies the Peak1 component. This component stores the Y-coordinates of the extracted peaks, in the pixel coordinate system of the image of the laser line; this is stored in Data16 pixel format. This is useful to display the locations of the extracted peaks on top of the laser line image (intensity component of a single-profile scan). Values are encoded with 5 bits of fixed-point precision. The value 65535 denotes the absence of a peak. This component has the GenICam custom component type 2 (that is, 0xFF02). This component is available when RegionSelector is set to Scan3dExtraction0 .
ComponentEnable [RegionSelector] [ComponentSelector]	Sets whether to enable for output the selected component.	
	True	Specifies the selected component is enabled for output.
	False	Specifies the selected component is not enabled for output.
ComponentIDValue [RegionSelector] [ComponentSelector]	Returns the identifier value that corresponds to the selected component.	

Feature name	Description	
	Feature value	Description
PixelFormat [RegionSelector] [ComponentSelector]	Returns the pixel format of the selected component. This feature is read only	
	Mono8	Specifies the selected component is in a Mono8 pixel format.
	Data8	Specifies the selected component is in a Data8 pixel format.
	Data16	Specifies the selected component is in a Data16 pixel format.
	Coord3D_ABC32f_Planar	Specifies the selected component is in a 3D coordinate A-B-C 32-bit floating point planar pixel format.
	Coord3d_C16	Specifies the selected component is in a 3D coordinate C 16-bit pixel format.
	Confidence8	Specifies the selected component is in a Confidence8 pixel format.
DecimationVerticalMode	Sets which vertical subsampling mode to use to subsample the laser line image. The vertical resolution of the laser line image is reduced by the specified vertical decimation factor. Subsampling is performed on the image sensor before any processing takes place and will affect the value of Height for the intensity component.	
	Discard	Specifies that the value of every Nth vertical pixel is kept, while the others are discarded.
DecimationVertical	Sets the vertical decimation factor (subsampling factor) to use to subsample the laser line image. A vertical decimation operation selects rows at regular intervals and reduces the vertical resolution (height) of the laser line images. The number of peaks remains the same, but their resolution reduce is reduced. For information on subsampling, see <i>Increasing acquisition speed using subsampling</i> section, in <i>Chapter 4: Understanding and setting the features of your Zebra Altiz</i> . Note that, when using the Multi-Altiz Plugin, the value set on the main Zebra Altiz 4200 unit copies over to secondary Zebra Altiz 4200 units automatically.	
	1	Specifies vertical subsampling is not enabled.
	2	Specifies vertical subsampling is enabled with a factor of 2.
TestPattern	Sets the type of test pattern that is generated by the sensor.	
	Off	Specifies that the image is coming from the sensor.
	On	Specifies that the test pattern is enabled.

Acquisition Control

The **Acquisition Control** category groups features related to the acquisition of a frame (scan), including trigger and exposure control. For information, see the *Setting up frame triggers for single-profile scans or multi-profile surface scans* section, the *Specifying scan step when using a constant line (profile) rate* section, and the *Specifying displacement when using a line (profile) trigger* section, in *Chapter 4: Understanding and setting the features of your Zebra AltiZ 4200*.

Feature name	Description	
	Feature value	Description
AcquisitionStatusSelector	Sets which type of acquisition Zebra AltiZ 4200 will perform.	
	AcquisitionActive	Specifies that Zebra AltiZ 4200 will perform a continuous acquisition.
	AcquisitionTriggerWait	Specifies that Zebra AltiZ 4200 will wait for a trigger to perform an acquisition.
AcquisitionStatus [AcquisitionStatusSelector]	Returns the acquisition status of the Zebra AltiZ 4200.	
AcquisitionProgress	Returns the count of profiles acquired in the current frame.	
AcquisitionMode	Sets the acquisition mode.	
	Continuous	Specifies that frames are captured continuously, until stopped with the AcquisitionStop command.
AcquisitionStart	Starts acquisition. This is handled automatically by Aurora Imaging Capture Works, Aurora Image Library (when performing a grab or MdigProcess), and Aurora Design Assistant. Zebra AltiZ 4200 captures frames continuously until stopped (AcquisitionMode set to Continuous). If you want to capture using a frame trigger and/or line (profile) trigger, the triggers must be enabled before calling AcquisitionStart . For more information, see <i>Setting up frame triggers for single-profile scans or multi-profile surface scans</i> section, in <i>Chapter 4: Understanding and setting the features of your Zebra AltiZ 4200</i> .	
AcquisitionStop	Sets to stop the acquisition at the end of the current frame. This is handled automatically by Aurora Imaging Capture Works when performing a grab of MdigProcess.	
AcquisitionLineRateEnable	Sets whether AcquisitionLineRate is writable and can be set manually. By default, this is set to False .	
	True	Specifies AcquisitionLineRate can be manually specified.
	False	Specifies AcquisitionLineRate is set automatically to AcquisitionLineRateMax .
AcquisitionLineRateMax	Sets the maximum allowed line (profile) rate, in lines/sec (that is, Hz). Features that can change this value include: ExposureTime , Scan3dVolumeSizeZWorld , Scan3dVolumeOffsetZWorld , and PayloadSize (if the amount of data is near the network interface limit). This feature is read only.	

Feature name	Description	
	Feature value	Description
AcquisitionLineRate	Sets the acquisition rate at which line profiles (laser line images) are captured, in lines/sec (that is, Hz). To specify an explicit value, AcquisitionLineRateEnable must be set to True . If you specify a value greater than the maximum, you will get an error. If the maximum changes so that it becomes smaller than the current value of AcquisitionLineRate , AcquisitionLineRate is automatically set to the maximum. By default, this feature is set to AcquisitionLineRateMax and is read only.	
AcquisitionLinePeriod	Returns the length of time to capture one row (profile) of the scan, in msec; this is also referred to as line period. This is length of time to capture one laser line (profile) image. This feature is read only.	
AcquisitionFrameRateMax	Returns the maximum possible frame rate, in frames/sec (that is, Hz). This feature is read only.	
AcquisitionFrameRate	Returns the acquisition rate at which frames are captured, in frames/sec (that is, Hz). This feature is read only.	
AcquisitionFramePeriod	Returns the length of time to capture one frame (scan), in sec; this is also referred to as frame period. This feature is read only.	
TriggerSelector	Sets the type of trigger to configure.	
	FrameStart	Specifies to configure the frame start trigger. This trigger starts the capture of one frame (either a single-profile scan or multi-profile surface scan).
	LineStart	Specifies to configure the line (profile) trigger. This trigger starts the capture of one row of a frame (scan). This also corresponds to the trigger that starts the capture of the laser line image from which the profile is extracted.
	FrameActive	Specifies to configure the frame active trigger. This trigger controls the duration of one frame (either a single-profile scan or a multi-profile scan). Zebra Altiz 4200 will acquire profiles for as long as the frame active trigger signal is active. Use TriggerActivation to set the active level of the trigger signal. By default, it is set to LevelHigh ; Zebra Altiz 4200 starts the capture of a frame when the trigger signal rises and stops the capture when the signal falls.
TriggerSource [TriggerSelector]	Sets which source to use for triggering. By default, this feature is set to Line0 .	
	Line0	Specifies to use auxiliary line 0 as the trigger source.
	Line1	Specifies to use auxiliary line 1 as the trigger source.
	Line2	Specifies to use auxiliary line 2 as the trigger source.
	Line3	Specifies to use auxiliary line 3 as the trigger source.
	Encoder0	Specifies to use encoder 0 output signal as the trigger source.
	Software	Specifies that the trigger source will be generated using the TriggerSoftware command.
	Timer0End	Specifies to use timer 0 end signal as the trigger source.
Timer1End	Specifies to use timer 1 end signal as the trigger source.	
	Timer2End	Specifies to use timer 2 end signal as the trigger source.

Feature name	Description	
	Feature value	Description
TriggerSource [TriggerSelector] (Continued)...	Timer3End	Specifies to use timer 3 end signal as the trigger source.
	Counter0End	Specifies to use counter 0 end signal as the trigger source.
	Counter1End	Specifies to use counter 1 end signal as the trigger source.
	Counter2End	Specifies to use counter 2 end signal as the trigger source.
	Counter3End	Specifies to use counter 3 end signal as the trigger source.
	LogicBlock0	Specifies to use logic block 0 output signal as the trigger source.
	LogicBlock1	Specifies to use logic block 1 output signal as the trigger source.
	LogicBlock2	Specifies to use logic block 2 output signal as the trigger source.
	LogicBlock3	Specifies to use logic block 3 output signal as the trigger source.
	ObjectDetect	Specifies to use Zebra Altiz 4200 object detection as the trigger source. The Object Detect Control category, under Acquisition Control, provides features to set an object detection region. This setting is supported for a FrameStart or FrameActive trigger selector.
	SoftwareSignal0	Specifies to use software signal 0, generated using the SoftwareSignalPulse command, as the trigger source.
	SoftwareSignal1	Specifies to use software signal 1, generated using the SoftwareSignalPulse command, as the trigger source.
	SoftwareSignal1	Specifies to use software signal 1, generated using the SoftwareSignalPulse command, as the trigger source.
	SoftwareSignal2	Specifies to use software signal 2, generated using the SoftwareSignalPulse command, as the trigger source.
	SoftwareSignal3	Specifies to use software signal 3, generated using the SoftwareSignalPulse command, as the trigger source.
	Timer0Start	Specifies to use timer 0 start signal as the trigger source.
	Timer1Start	Specifies to use timer 1 start signal as the trigger source.
	Timer2Start	Specifies to use timer 2 start signal as the trigger source.
	Timer3Start	Specifies to use timer 3 start signal as the trigger source.
	Counter0Start	Specifies to use counter 0 start signal as the trigger source.
Counter1Start	Specifies to use counter 1 start signal as the trigger source.	
Counter2Start	Specifies to use counter 2 start signal as the trigger source.	
Counter3Start	Specifies to use counter 3 start signal as the trigger source.	
UserOutput0	Specifies to use user output register bit 0 signal as the trigger source.	
UserOutput1	Specifies to use user output register bit 1 signal as the trigger source.	

Feature name	Description	
	Feature value	Description
TriggerSoftware [TriggerSelector]	Sets the software trigger to execute.	
TriggerMode [TriggerSelector]	Sets whether the selected trigger is enabled or disabled. You can enable a line (profile) trigger without enabling a frame start trigger. If both a frame start trigger and a line trigger are enabled, scanning starts upon the first line trigger received after the frame trigger; any line trigger received before the frame trigger is ignored. By default, this feature is set to Off .	
	On	Specifies to enable the trigger.
	Off	Specifies to disable the trigger.
TriggerActivation [TriggerSelector]	Sets the activation mode of the trigger. Use TriggerMode to enable the trigger. By default, this feature is set to RisingEdge . Note that this is not available when using ObjectDectect .	
	RisingEdge	Specifies that the trigger is considered valid upon a rising edge (a low-to-high transition) of the source signal. This is not available if TriggerSelector is set to FrameActive .
	FallingEdge	Specifies that the trigger is considered valid upon a falling edge (a high-to-low transition) of the source signal. This is not available if TriggerSelector is set to FrameActive .
	AnyEdge	Specifies that the trigger is considered valid upon a rising or falling edge of the source signal. This is not available if TriggerSelector is set to FrameActive .
	LevelHigh	Specifies that the trigger is considered valid as long as the level of the source signal is high.
	LevelLow	Specifies that the trigger is considered valid as long as the level of the source signal is low.
TriggerOverlap [TriggerSelector]	Sets whether a trigger is latched at any time during the capture of a previous line. This feature is available when TriggerSelector is set to LineStart . By default, this feature is set to Off .	
	Off	Specifies that no other trigger can be latched during the capture of one row of a frame (scan).
	PreviousLine	Specifies that another trigger can be latched simultaneously while one row of a frame is being captured (scan).
ExposureTime	Sets the exposure time of the image sensor, in μsec . By default, this is set to 500 μsec .	
ExposureAuto	Sets the exposure mode. ExposureAuto allows exposure to adjust per frame and ensures the proper saturation of pixels in a region of interest, based on the required laser line width set by ExposureAutoWidthMin and ExposureAutoWidthMax . Note that the maximum allowed exposure depends on the frame rate, which means the optimum exposure might not be possible at very high frame rates. This feature is set to Off by default.	
	Off	Specifies to not enable ExposureAuto . Your sensor will instead use the exposure time set using ExposureTime .
	Continuous	Specifies to use automatic exposure during acquisition.

Feature name	Description	
	Feature value	Description
ExposureAutoWidthMin	Sets the required minimum line width to use for calculating automatic exposure when ExposureAuto is enabled. The line width is the average number of saturated pixels (255) found across the laser line within the defined Region of Interest (ROI), as established by ExposureAutoStartX and ExposureAutoEndX . If the line width in a given frame is below this value, the exposure will be increased for the following frame. This feature can be set to float values ranging from 1.0 to 15.0 pixels. By default, this feature is set to 2.5 pixels. Note that you should not set ExposureAutoWidthMin to a value that is larger than ExposureAutoWidthMax .	
ExposureAutoWidthMax	Sets the required maximum line width to use for calculating automatic exposure when ExposureAuto is enabled. The line width is the average number of saturated pixels (255) found across the laser line within the defined Region of Interest (ROI), as established by ExposureAutoStartX and ExposureAutoEndX . If the line width in a given frame is above this value, the exposure will be decreased for the following frame. This feature is set to a float value from 1.0 to 15.0 pixels. By default, this feature is set to 7.5. Note that you should not set ExposureAutoWidthMax to a value that is less than ExposureAutoWidthMin .	
ExposureAutoStartX	Sets the start of the Region of Interest (ROI) used for calculating automatic exposure. This sets the location of the far left region of the scanned object along the X-axis, relative to the Anchor coordinate system, when ExposureAuto is enabled. This value is set in mm.	
ExposureAutoEndX	Sets the end of the Region of Interest (ROI) used for calculating automatic exposure. This sets the location of the far right region of the scanned object along the X-axis, relative to the Anchor coordinate system, when ExposureAuto is enabled. This value is set in mm.	
HDRMode	Sets HDR mode. The high dynamic range (HDR) feature is used to scan a model with different surface reflectiveness, while maintaining preferred accuracy. If an object has bright areas and also dark areas, bright areas will produce a wide laser line and dark areas will produce a thin laser line, which regulates the accuracy of the output. This feature is set to Disabled by default.	
	Average	Specifies to enable HDRMode . This will average the exposure of the bright areas and the dark areas, to make it easier to accurately extract peaks from both areas of the image.
	Disabled	Specifies to not use HDRMode during acquisition.
HDRSecondExposurePercentage	Sets the exposure period for a secondary exposure, after ExposureTime . Use a float value from 0.0 to 100.0. By default, this feature is set to 25.0. For example, if ExposureTime is 1000 μ s and HDRSecondExposurePercentage is set to 25.0, the exposure of the even lines on the image sensor is set to 1000 μ s, and the exposure of the odd lines on the image sensor is set to 250 μ s. This feature is not used when HDRMode is set to Off .	

Vibration Control

The **Vibration Control** category groups features for configuring vibration control. To use these features, first ensure that you have set **VibrationEnable** to **True**.

Feature name	Description	
	Feature value	Description
VibrationEnable	Sets whether to enable vibration compensation, along the Z-axis. This feature removes vibration distortions on a surface scan in real time. When VibrationEnable is set to True , Zebra Altiz 4200 will calculate the vibration expected for each profile, which assists in making the scan more accurate. Vibration compensation requires an established location for the floor, which must be constant throughout the scan for proper reference (for example, the X and Z axis location of a conveyor belt). The location of the floor acquired throughout the scan is established using the VibrationFloorStart features below. This feature is set to False by default.	
	False	Specifies to not enable vibration compensation.
	True	Specifies to enable vibration compensation.
VibrationFloorStartX	Sets the start location of the floor along the X-axis. This must be a location on the scan that is continuously visible by the sensor's FoV during acquisition, but is not covered by the scan object. By default, this is the far left of the X-axis along the bottom of the FoV, within the Anchor coordinate system. This value is set in mm.	
VibrationFloorEndX	Sets the end location of the floor along the X-axis. This must be a location on the scan that is continuously visible by the sensor's FoV during acquisition, but is not covered by the scan object. By default, this is the far right of the X-axis along the bottom of the FoV, within the Anchor coordinate system. This value is set in mm.	
VibrationFloorStartZ	Sets the start location of the floor along the Z-axis. Depending on your Anchor coordinate system mode, this can either be at the top of the floor (when using the ReferencePoint or Distance Anchor coordinate system mode), or bottom of the floor (when using the Height Anchor coordinate system mode), but will always be the value closest to 0. This value is set in mm.	
VibrationFloorEndZ	Sets the end location of the floor along the Z-axis. Depending on your Anchor coordinate system mode, this can either be at the top of the floor (when using the ReferencePoint or Distance Anchor coordinate system modes), or bottom of the floor (when using the Height Anchor coordinate system mode), but will always be the value furthest from 0. This value is set in mm.	

Object Detect Control

The **Object Detect Control** category groups features for configuring object detection, which is a trigger source that starts a grab when an object is detected within a region of the scan area. To use these features, first ensure that you have set **TriggerSource** to **ObjectDetect**. If the object is of a known length, you set **TriggerSelector** to **FrameStart**. In this case, the end of frame occurs when the end of **Scan3dVolumeLengthWorld** is reached. If the object is of a variable length, you set **TriggerSelector** to **FrameActive**. In this case, the end of frame occurs when a continuous gap along the Y-axis, as specified by **ObjectDetectGapY**, is encountered after the object, or **Scan3dVolumeLengthWorld** is reached.

Feature name	Description	
	Feature value	Description
ObjectDetectRegionStartX	Specifies the start of the object detection region, along the X-axis, in which to detect objects (in mm).	
ObjectDetectRegionEndX	Specifies the end of the object detection region, along the X-axis, in which to detect objects (in mm).	
ObjectDetectThresholdZ	Specifies the Z-threshold that delimits the region, along the Z-axis, in which to detect objects (in mm). Specify the Z-threshold relative to the Anchor coordinate system. An object must be between ObjectDetectThresholdZ and the near FoV to be detected. Note that if the Anchor coordinate system is moved after setting this feature, it will automatically be adjusted.	
ObjectDetectMinimumXYArea	Specifies the minimum area (in mm ²) that an object must have when projected on the XY-plane; otherwise, grabbed data is discarded if the object does not meet this minimum size. All peaks inside of the object detection region along the length of the object are used to calculate the area of an object, even if some peaks are not contiguous.	
ObjectDetectGapY	Specifies the length, along the Y-axis (in mm), of the contiguous gap that signifies the end of an object. An object is not considered complete until an area of this length is scanned without any peaks in the object detection region. This gap area is included in the transmitted data as part of the acquired frame. This feature is only used when TriggerSelector is set to FrameActive .	
ObjectDetectPrecedingProfiles	True	Specifies that the transmitted data begins a set number of profiles before the detected object.
	False	Specifies that the transmitted data begins at the first profile that contains the detected object.
ObjectDetectTotalAccepted [Statistics]	Returns the number of detected objects with a projected XY-area greater than ObjectDetectMinimumXYArea . This value is only incremented when ObjectDetect is set as a trigger source. To reset this value, you must use ObjectDetectResetStatistics .	
ObjectDetectTotalRejected [Statistics]	Returns the number of detected objects with a projected XY-area less than ObjectDetectMinimumXYArea . This means an object was detected in the object detection region, but did not meet the minimum requirements. This value is only incremented when ObjectDetect is set as a trigger source. To reset this value, you must use ObjectDetectResetStatistics .	
ObjectDetectResetStatistics [Statistics]	Resets ObjectDetectTotalAccepted and ObjectDetectTotalRejected .	

Light Control

The **Light Control** category groups features that control the Zebra Altiz 4200 laser (such as laser brightness and laser mode). For information on how to set laser intensity, see *Laser control and exposure* section, in *Chapter 4: Understanding and setting the features of your Zebra Altiz 4200*.

Feature name	Description	
	Feature value	Description
LightLaserBrightness	Sets the brightness of the laser output, as a percentage. This values can range from 0-100. By default, this feature is set to 50% .	
LightLaserMode	Sets when the laser will emit light. By default, this feature is set to Automatic .	
	Off	Specifies a software control to ensure the laser does not emit light. This remains true, even during the exposure time of acquisition.
	On	Specifies that the laser emits light continuously, at a fixed intensity, which overrides the set laser intensity. This is useful when you need to see the laser so that you can make adjustments. This mode is only available as long as the device is not grabbing; once a grab starts, this feature will switch to Automatic . After this device reboots, this feature is also set back to Automatic and therefore should not be part of a user set.
	Automatic	Specifies to enable the laser to emit light only during the exposure time of acquisition.

Encoder Control

The **Encoder Control** category groups features that control and monitor the quadrature encoder interface of Zebra AltiZ 4200 (such as encoder source, encoder divider, output mode, and encoder reset). For information on how to use an encoder with Zebra AltiZ 4200 to generate a line (profile) trigger, see *Specifying displacement when using a line (profile) trigger* section, in *Chapter 4: Understanding and setting the features of your Zebra AltiZ 4200*.

Feature name	Description	
	Feature value	Description
EncoderSourceA	Sets the auxiliary input line on which to receive encoder bit A (bit 0). By default, this feature is set to Line0 .	
	Line0	Specifies to use auxiliary signal 0 as the source for bit A.
	Line1	Specifies to use auxiliary signal 1 as the source for bit A.
	Line2	Specifies to use auxiliary signal 2 as the source for bit A.
	Line3	Specifies to use auxiliary signal 3 as the source for bit A.
EncoderSourceB	Sets the auxiliary input line on which to receive encoder bit B (bit 1).	
	Line0	Specifies to use auxiliary signal 0 as the source for bit B.
	Line1	Specifies to use auxiliary signal 1 as the source for bit B.
	Line2	Specifies to use auxiliary signal 2 as the source for bit B.
	Line3	Specifies to use auxiliary signal 3 as the source for bit B.
EncoderOutputMode	Sets the conditions for the encoder interface to generate a valid encoder output signal. By default, this feature is set to PositionUp .	
	Off	Specifies that no output pulse is generated.
	PositionUp	Specifies that output pulses are generated at any new position that is in the positive direction. No output pulse is generated if the encoder reverses, until it passes the same point at which the reversal began.
	DirectionUp	Specifies that output pulses are generated at any position that is in the positive direction. Any position in the negative direction is ignored.
	DirectionDown	Specifies that output pulses are generated at any position that is in the negative direction. Any position in the positive direction is ignored.
	Motion	Specifies that output pulses are generated at all motion increments, regardless of direction.
EncoderResolution	Sets the distance between each encoder step (resolution), set in mm (per encoder step). By default, this is set to 0.1 .	

Feature name	Description	
	Feature value	Description
EncoderDivider	Sets how many encoder increments/decrements are needed to generate a pulse on the encoder interface output signal. If you are not using an encoder as the acquisition trigger source (TriggerSource is not set to Encoder0), this feature is writable; otherwise, this feature is computed automatically.	
EncoderStatus	Returns the status of the encoder. This feature is read only.	
	EncoderIdle	Specifies the encoder is not active.
	EncoderUp	Specifies the encoder's last increment was in the positive direction.
	EncoderDown	Specifies the encoder's last increment was in the negative direction.
	EncoderStatic	Specifies that no motion has been detected within the designated EncoderTimeout time.
EncoderTimeout	Sets the maximum time interval between encoder increments before the status turns to EncoderStatic , set in usec. By default, this feature is set to 1000 usec .	
EncoderReset	Resets the encoder position counter. The encoder position counter will start counting immediately after the reset. This feature can be used independently from EncoderResetSource . Note that the value of the encoder position counter at the time of reset is automatically latched and can be retrieved using EncoderValueAtReset .	
EncoderResetSource	Sets the signal that will reset the encoder position counter. By default, this feature is set to AcquisitionEnd .	
	Off	Specifies that the encoder position counter reset trigger is disabled.
	AcquisitionStart	Specifies to use the acquisition start signal as the encoder position counter reset signal.
	AcquisitionEnd	Specifies to use the acquisition end signal as the encoder position counter reset signal.
	SoftwareSignal0	Specifies to use software signal 0, generated using the SoftwareSignalPulse command, as the encoder position counter reset signal.
	SoftwareSignal1	Specifies to use software signal 1, generated using the SoftwareSignalPulse command, as the encoder position counter reset signal.
	SoftwareSignal2	Specifies to use software signal 2, generated using the SoftwareSignalPulse command, as the encoder position counter reset signal.
	SoftwareSignal3	Specifies to use software signal 3, generated using the SoftwareSignalPulse command, as the encoder position counter reset signal.

Feature name	Description	
	Feature value	Description
EncoderResetSource (Continued)...	Line0	Specifies to use auxiliary line 0 as the encoder position counter reset signal.
	Line1	Specifies to use auxiliary line 1 as the encoder position counter reset signal.
	Line2	Specifies to use auxiliary line 2 as the encoder position counter reset signal.
	Line3	Specifies to use auxiliary line 3 as the encoder position counter reset signal.
	Timer0End	Specifies to use the timer 0 end signal as the encoder position counter reset signal.
	Timer1End	Specifies to use the timer 1 end signal as the encoder position counter reset signal.
	Timer2End	Specifies to use the timer 2 end signal as the encoder position counter reset signal.
	Timer3End	Specifies to use the timer 3 end signal as the encoder position counter reset signal.
	Counter0End	Specifies to use the counter 0 end signal as the encoder position counter reset signal.
	Counter1End	Specifies to use the counter 1 end signal as the encoder position counter reset signal.
	Counter2End	Specifies to use the counter 2 end signal as the encoder position counter reset signal.
	Counter3End	Specifies to use the counter 3 end signal as the encoder position counter reset signal.
	Timer0Start	Specifies to use the timer 0 start signal as the encoder position counter reset signal.
	Timer1Start	Specifies to use the timer 1 start signal as the encoder position counter reset signal.
	Timer2Start	Specifies to use the timer 2 start signal as the encoder position counter reset signal.
	Timer3Start	Specifies to use the timer 3 start signal as the encoder position counter reset signal.
Counter0Start	Specifies to use the counter 0 start signal as the encoder position counter reset signal.	
Counter1Start	Specifies to use the counter 1 start signal as the encoder position counter reset signal.	
Counter2Start	Specifies to use the counter 2 start signal as the encoder position counter reset signal.	

Feature name	Description	
	Feature value	Description
EncoderResetSource (Continued)...	Counter3Start	Specifies to use the counter 3 start signal as the encoder position counter reset signal.
	LogicBlock0	Specifies to use the logic block 0 output signal as the encoder position counter reset signal.
	LogicBlock1	Specifies to use the logic block 1 output signal as the encoder position counter reset signal.
	LogicBlock2	Specifies to use the logic block 2 output signal as the encoder position counter reset signal.
	LogicBlock3	Specifies to use the logic block 3 output signal as the encoder position counter reset signal.
	UserOutput0	Specifies to use the user output register bit 0 signal as the encoder position counter reset signal.
	UserOutput1	Specifies to use the user output register bit 1 signal as the encoder position counter reset signal.
EncoderResetActivation	Sets the activation mode of the encoder position counter reset signal. By default, this feature is set to RisingEdge .	
	RisingEdge	Specifies that the encoder position counter resets its value upon a rising edge (a low-to-high transition) of the reset signal.
	FallingEdge	Specifies that the encoder position counter resets its value upon a falling edge (a high-to-low transition) of the reset signal.
	AnyEdge	Specifies that the trigger is considered valid upon a rising or falling edge of the reset signal.
	LevelLow	Specifies that the encoder position counter resets its value as long as the level of the reset signal is low.
	LevelHigh	Specifies that the encoder position counter resets its value as long as the level of the reset signal is high.
EncoderValue	Sets or returns the current value of the position counter of the encoder. Writing to EncoderValue is typically only used to set the start value of the position counter. By default, this feature is set to 1 .	
EncoderValueAtReset	Returns the value of the position counter of the encoder, found before it was last reset. This feature is read only.	

Digital IO Control

The **Digital I/O Control** category groups features that control the auxiliary input and output lines. For information on how to connect external devices to the auxiliary I/O lines of Zebra AltiZ 4200, see the *Connecting devices to the auxiliary output lines* section and the *Connecting devices to the auxiliary input lines* section, in *Chapter 2: Powering and connecting to your Zebra AltiZ 4200*. For pinout information, see the *Digital I/O and power connector* section, in *Appendix B: Technical reference*.

Feature name	Description	
	Feature value	Description
LineSelector	Sets which auxiliary line to control or inquire.	
	Line0	Specifies to use auxiliary line 0 (input) for I/O control. Note that, when using the multi-altiz cable, Line0 is used to receive Line4 by default on the secondary Zebra AltiZ 4200.
	Line1	Specifies to use auxiliary line 1 (input) for I/O control. Note that, when using the multi-altiz cable, Line1 is used to receive Line5 by default on the secondary Zebra AltiZ 4200.
	Line2	Specifies to use auxiliary line 2 (input) for I/O control.
	Line3	Specifies to use auxiliary line 3 (input) for I/O control.
	Line4	Specifies to use auxiliary line 4 (output) for I/O control. Note that, when using the multi-altiz cable, Line4 is used to trigger ExposureActive .
	Line5	Specifies to use auxiliary line 5 (output) for I/O control. Note that, when using the multi-altiz cable, Line5 is used to trigger LogicBlock0 .
LineMode [LineSelector]	Returns whether the physical line is used to input or output a signal.	
	Input	Specifies the physical line is used to input a signal.
	Output	Specifies the physical line is used to output a signal.
LineInverter [LineSelector]	Sets whether to invert the signal on the selected line. By default, this feature is set to False .	
	True	Specifies to invert the signal on the selected line.
	False	Specifies not to invert the signal on the selected line.
LineStatus [LineSelector]	Returns the current status of the selected line. This is read only.	
	True	Specifies the level of the signal on the line is high.
	False	Specifies the level of the signal on the line is low.

Feature name	Description	
	Feature value	Description
LineSource [LineSelector]	Sets the I/O source signal to output on the selected line. By default, this feature is set to UserOutput0 . This feature is only available if LineSelector is set to an output line (that is, if LineSelector is set to Line4 or Line5).	
	UserOutput0	Specifies to output user output register bit 0 on the selected line.
	UserOutput1	Specifies to output user output register bit 1 on the selected line.
	ExposureActive	Specifies to output the exposure active signal on the selected line.
	Timer0Active	Specifies to output the timer 0 active signal on the selected line.
	Timer1Active	Specifies to output the timer 1 active signal on the selected line.
	Timer2Active	Specifies to output the timer 2 active signal on the selected line.
	Timer3Active	Specifies to output the timer 3 active signal on the selected line.
	Counter0Active	Specifies to output the counter 0 active signal on the selected line.
	Counter1Active	Specifies to output the counter 1 active signal on the selected line.
	Counter2Active	Specifies to output the counter 2 active signal on the selected line.
	Counter3Active	Specifies to output the counter 3 active signal on the selected line.
	Encoder0	Specifies to output the encoder interface 0 output signal on the selected line.
	Input0	Specifies to output the signal arriving on auxiliary line 0 (input) on the selected line.
	Input1	Specifies to output the signal arriving on auxiliary line 1 (input) on the selected line.
	Input2	Specifies to output the signal arriving on auxiliary line 2 (input) on the selected line.
	Input3	Specifies to output the signal arriving on auxiliary line 3 (input) on the selected line.
	LogicBlock0	Specifies to output the auxiliary logic block 0 output signal on the selected line.
LogicBlock1	Specifies to output the auxiliary logic block 1 output signal on the selected line.	
LogicBlock2	Specifies to output the auxiliary logic block 2 output signal on the selected line.	
LogicBlock3	Specifies to output the auxiliary logic block 3 output signal on the selected line.	
UserOutputSelector	Sets the bit of the user output register to control/inquire. By default, this feature is set to UserOutput0 .	
	UserOutput0	Specifies to use bit 0 of the user output register.
	UserOutput1	Specifies to use bit 1 of the user output register.
UserOutputValue [UserOutputSelector]	Sets whether the bit selected by UserOutputSelector is enabled or not. By default, this feature is set to False .	
	True	Specifies to enable the bit set by UserOutputSelector .
	False	Specifies to disable the bit set by UserOutputSelector .

Counter and Timer Control

The **Counter and Timer Control** category groups features that control and monitor the counters and timers.

Feature name	Description	
	Feature value	Description
CounterSelector	Sets which counter to configure.	
	Counter0	Specifies to configure counter 0.
	Counter1	Specifies to configure counter 1.
	Counter2	Specifies to configure counter 2.
	Counter3	Specifies to configure counter 3.
CounterEventSource [CounterSelector]	Sets the event that will be the source for the counter increment. By default, this feature is set to Off .	
	Off	Specifies the counter is disabled.
	AcquisitionStart	Specifies to use the acquisition start signal as the counter source.
	AcquisitionEnd	Specifies to use the acquisition end signal as the counter source.
	ExposureStart	Specifies to use the exposure start signal as the counter source.
	SoftwareSignal0	Specifies to use software signal 0, generated using the SoftwareSignalPulse command, as the counter source.
	SoftwareSignal1	Specifies to use software signal 1, generated using the SoftwareSignalPulse command, as the counter source.
	SoftwareSignal2	Specifies to use software signal 2, generated using the SoftwareSignalPulse command, as the counter source.
	SoftwareSignal3	Specifies to use software signal 3, generated using the SoftwareSignalPulse command, as the counter source.
	Line0	Specifies to use auxiliary line 0 as the counter source.
	Line1	Specifies to use auxiliary line 1 as the counter source.
	Line2	Specifies to use auxiliary line 2 as the counter source.
	Line3	Specifies to use auxiliary line 3 as the counter source.
	Timer0End	Specifies to use the timer 0 end signal as the counter source.
	Timer1End	Specifies to use the timer 1 end signal as the counter source.
	Timer2End	Specifies to use the timer 2 end signal as the counter source.
	Timer3End	Specifies to use the timer 3 end signal as the counter source.
Counter0End	Specifies to use the counter 0 end signal as the counter source.	
Counter1End	Specifies to use the counter 1 end signal as the counter source.	
Counter2End	Specifies to use the counter 2 end signal as the counter source.	

Feature name	Description	
	Feature value	Description
CounterEventSource [CounterSelector] (Continued)...	Counter3End	Specifies to use the counter 3 end signal as the counter source.
	Encoder0	Specifies to use the encoder interface 0 output signal as the counter source.
	Timer0Start	Specifies to use the timer 0 start signal as the counter source.
	Timer1Start	Specifies to use the timer 1 start signal as the counter source.
	Timer2Start	Specifies to use the timer 2 start signal as the counter source.
	Timer3Start	Specifies to use the timer 3 start signal as the counter source.
	Counter0Start	Specifies to use the counter 0 start signal as the counter source.
	Counter1Start	Specifies to use the counter 1 start signal as the counter source.
	Counter2Start	Specifies to use the counter 2 start signal as the counter source.
	Counter3Start	Specifies to use the counter 3 start signal as the counter source.
	LogicBlock0	Specifies to use the logic block 0 output signal as the counter source.
	LogicBlock1	Specifies to use the logic block 1 output signal as the counter source.
	LogicBlock2	Specifies to use the logic block 2 output signal as the counter source.
LogicBlock3	Specifies to use the logic block 3 output signal as the counter source.	
CounterEventActivation [CounterSelector]	Sets the activation mode of the event signal to count (counter source). This feature sets the transition to count on the event signal. By default, this feature is set to RisingEdge .	
	RisingEdge	Specifies to count on the rising edge (low-to-high transition) of the signal.
	FallingEdge	Specifies to count on the falling edge (high-to-low transition) of the signal.
	AnyEdge	Specifies to count upon a rising or falling edge of the signal.

Feature name	Description	
	Feature value	Description
CounterResetSource [CounterSelector]	Sets the source that will reset the counter. By default, this feature is set to Off .	
	Off	Specifies that the counter reset is disabled.
	AcquisitionStart	Specifies to use the acquisition start signal as the counter reset signal.
	AcquisitionEnd	Specifies to use the acquisition end signal as the counter reset signal.
	ExposureStart	Specifies to use the exposure start signal as the counter reset signal.
	SoftwareSignal0	Specifies to use software signal 0, generated using the SoftwareSignalPulse command, as the counter reset signal.
	SoftwareSignal1	Specifies to use software signal 1, generated using the SoftwareSignalPulse command, as the counter reset signal.
	SoftwareSignal2	Specifies to use software signal 2, generated using the SoftwareSignalPulse command, as the counter reset signal.
	SoftwareSignal3	Specifies to use software signal 3, generated using the SoftwareSignalPulse command, as the counter reset signal.
	Line0	Specifies to use auxiliary line 0 as the counter reset signal.
	Line1	Specifies to use auxiliary line 1 as the counter reset signal.
	Line2	Specifies to use auxiliary line 2 as the counter reset signal.
	Line3	Specifies to use auxiliary line 3 as the counter reset signal.
	Timer0End	Specifies to use the timer 0 end signal as the counter reset signal.
	Timer1End	Specifies to use the timer 1 end signal as the counter reset signal.
	Timer2End	Specifies to use the timer 2 end signal as the counter reset signal.
	Timer3End	Specifies to use the timer 3 end signal as the counter reset signal.
	Counter0End	Specifies to use the counter 0 end signal as the counter reset signal.
	Counter1End	Specifies to use the counter 1 end signal as the counter reset signal.
	Counter2End	Specifies to use the counter 2 end signal as the counter reset signal.
	Counter3End	Specifies to use the counter 3 end signal as the counter reset signal.
	Encoder0	Specifies to use encoder interface 0 output signal as the counter reset signal.
	Timer0Start	Specifies to use the timer 0 start signal as the counter reset signal.
Timer1Start	Specifies to use the timer 1 start signal as the counter reset signal.	
Timer2Start	Specifies to use the timer 2 start signal as the counter reset signal.	

Feature name	Description	
	Feature value	Description
CounterResetSource [CounterSelector] (Continued)...	Timer3Start	Specifies to use the timer 3 start signal as the counter reset signal.
	Counter0Start	Specifies to use the counter 0 start signal as the counter reset signal.
	Counter1Start	Specifies to use the counter 1 start signal as the counter reset signal.
	Counter2Start	Specifies to use the counter 2 start signal as the counter reset signal.
	Counter3Start	Specifies to use the counter 3 start signal as the counter reset signal.
	LogicBlock0	Specifies to use the logic block 0 output signal as the counter reset signal.
	LogicBlock1	Specifies to use the logic block 1 output signal as the counter reset signal.
	LogicBlock2	Specifies to use the logic block 2 output signal as the counter reset signal.
	LogicBlock3	Specifies to use the logic block 3 output signal as the counter reset signal.
	UserOutput0	Specifies to use the user output register bit 0 signal as the counter reset signal.
	UserOutput1	Specifies to use the user output register bit 1 signal as the counter reset signal.
CounterResetActivation [CounterSelector]	Sets the activation mode of the counter reset signal. By default, this feature is set to RisingEdge .	
	RisingEdge	Specifies that the counter resets its value upon a rising edge (low-to-high transition) of the reset signal.
	FallingEdge	Specifies that the counter resets its value upon a falling edge (high-to-low transition) of the reset signal.
	AnyEdge	Specifies that the counter resets its value upon a rising or falling edge of the reset signal.
	LevelLow	Specifies that the counter resets its value as long as the level of the reset signal is low.
LevelHigh	Specifies that the counter resets its value as long as the level of the reset signal is high.	
CounterReset [CounterSelector]	Resets the counter. The counter will start counting immediately after the reset. This feature can be used independently from CounterResetSource .	
CounterValue [CounterSelector]	Sets the counter value. By default, this feature is set to 0 .	
CounterValueAtReset [CounterSelector]	Returns the value that a counter had just before it was last reset by a trigger or by an explicit CounterReset command. It is the last counter value latched before resetting the counter. This feature is read only.	

Feature name	Description	
	Feature value	Description
CounterDuration [CounterSelector]	Sets the duration of the counter (number of events to count). When the counter reaches the CounterDuration value, a CounterEnd event is generated, the CounterActive signal becomes inactive, and the counter stops counting until a new trigger happens or it is explicitly reset with CounterReset . By default, this feature is set to 10 .	
CounterStatus [CounterSelector]	Returns the current status of the counter. This feature is read only.	
	CounterIdle	Specifies that the counter is idle.
	CounterTriggerWait	Specifies that the counter is waiting for a start trigger.
	CounterActive	Specifies that the counter is counting for the specified duration.
	CounterCompleted	Specifies that the counter reached the CounterDuration count.
CounterTriggerSource [CounterSelector]	Sets the source that will trigger the counter to start counting (from 0 to CounterDuration). By default, this feature is set to Off .	
	Off	Specifies the counter trigger is disabled.
	AcquisitionStart	Specifies to use the acquisition start signal as the counter trigger signal.
	AcquisitionEnd	Specifies to use the acquisition end signal as the counter trigger signal.
	ExposureStart	Specifies to use the exposure start signal as the counter trigger signal.
	SoftwareSignal0	Specifies to use software signal 0, generated using the SoftwareSignalPulse command, as the counter trigger signal.
	SoftwareSignal1	Specifies to use software signal 1, generated using the SoftwareSignalPulse command, as the counter trigger signal.
	SoftwareSignal2	Specifies to use software signal 2, generated using the SoftwareSignalPulse command, as the counter trigger signal.
	SoftwareSignal3	Specifies to use software signal 3, generated using the SoftwareSignalPulse command, as the counter trigger signal.
	Line0	Specifies to use auxiliary line 0 as the counter trigger signal.
	Line1	Specifies to use auxiliary line 1 as the counter trigger signal.
	Line2	Specifies to use auxiliary line 2 as the counter trigger signal.
	Line3	Specifies to use auxiliary line 3 as the counter trigger signal.
	Timer0End	Specifies to use the timer 0 end signal as the counter trigger signal.
	Timer1End	Specifies to use the timer 1 end signal as the counter trigger signal.
	Timer2End	Specifies to use the timer 2 end signal as the counter trigger signal.
	Timer3End	Specifies to use the timer 3 end signal as the counter trigger signal.
	Counter0End	Specifies to use the counter 0 end signal as the counter trigger signal.

Feature name	Description	
	Feature value	Description
CounterTriggerSource [CounterSelector] (Continued)...	Counter1End	Specifies to use the counter 1 end signal as the counter trigger signal.
	Counter2End	Specifies to use the counter 2 end signal as the counter trigger signal.
	Counter3End	Specifies to use the counter 3 end signal as the counter trigger signal.
	Encoder0	Specifies to use the encoder interface 0 output signal as the counter trigger signal.
	Timer0Start	Specifies to use the timer 0 start signal as the counter trigger signal.
	Timer1Start	Specifies to use the timer 1 start signal as the counter trigger signal.
	Timer2Start	Specifies to use the timer 2 start signal as the counter trigger signal.
	Timer3Start	Specifies to use the timer 3 start signal as the counter trigger signal.
	Counter0Start	Specifies to use the counter 0 start signal as the counter trigger signal.
	Counter1Start	Specifies to use the counter 1 start signal as the counter trigger signal.
	Counter2Start	Specifies to use the counter 2 start signal as the counter trigger signal.
	Counter3Start	Specifies to use the counter 3 start signal as the counter trigger signal.
	LogicBlock0	Specifies to use the logic block 1 output signal as the counter trigger signal.
	LogicBlock1	Specifies to use the logic block 1 output signal as the counter trigger signal.
	LogicBlock2	Specifies to use the logic block 2 output signal as the counter trigger signal.
	LogicBlock3	Specifies to use the logic block 3 output signal as the counter trigger signal.
	UserOutput0	Specifies to use the user output register bit 0 signal as the counter trigger signal.
UserOutput1	Specifies to use the user output register bit 1 signal as the counter trigger signal.	

Feature name	Description	
	Feature value	Description
CounterTriggerActivation [CounterSelector]	Sets the activation mode of the trigger signal that starts the counter. By default, this feature is set to RisingEdge .	
	RisingEdge	Specifies to start counting upon a rising edge (low-to-high transition) of the trigger signal.
	FallingEdge	Specifies to start counting upon a falling edge (high-to-low transition) of the trigger signal.
	AnyEdge	Specifies to start counting upon a rising or falling edge of the trigger signal.
	LevelLow	Specifies to count as long as the level of the trigger signal is low.
	LevelHigh	Specifies to count as long as the level of the trigger signal is high.
TimerSelector	Sets which timer to configure.	
	Timer0	Specifies to configure timer 0.
	Timer1	Specifies to configure timer 1.
	Timer2	Specifies to configure timer 2.
	Timer3	Specifies to configure timer 3.
TimerDuration [TimerSelector]	Sets the duration of the timer output pulse, in μsec . By default, this feature is set to 0 usec .	
TimerDelay [TimerSelector]	Sets the delay, in μsec , between receiving the timer trigger and starting the timer (output pulse). By default, this feature is set to 0 usec .	
TimerReset [TimerSelector]	Resets the timer.	
TimerValue [TimerSelector]	Sets the value of the timer count, in μsec . You can read or write this value. Writing to TimerValue is typically only done to set a start value. By default, this feature is set to 0 usec .	
TimerStatus [TimerSelector]	Returns the current timer status. This feature is read only.	
	TimerIdle	Specifies the timer is idle.
	TimerTriggerWait	Specifies that the timer is waiting for a start trigger signal.
	TimerActive	Specifies that the timer is active.
	TimerCompleted	Specifies that the timer has completed.

Feature name	Description	
	Feature value	Description
TimerTriggerSource [TimerSelector]	Sets the source of the timer trigger. By default, this feature is set to Off .	
	Off	Specifies the timer trigger is disabled.
	AcquisitionStart	Specifies to use the acquisition start signal as the trigger source.
	AcquisitionEnd	Specifies to use the acquisition end signal as the trigger source.
	ExposureStart	Specifies to use the exposure start signal as the trigger source.
	SoftwareSignal0	Specifies to use software signal 0, generated using the SoftwareSignalPulse command, as the trigger source.
	SoftwareSignal1	Specifies to use software signal 1, generated using the SoftwareSignalPulse command, as the trigger source.
	SoftwareSignal2	Specifies to use software signal 2, generated using the SoftwareSignalPulse command, as the trigger source.
	SoftwareSignal3	Specifies to use software signal 3, generated using the SoftwareSignalPulse command, as the trigger source.
	Line0	Specifies to use auxiliary line 0 as the trigger source.
	Line1	Specifies to use auxiliary line 1 as the trigger source.
	Line2	Specifies to use auxiliary line 2 as the trigger source.
	Line3	Specifies to use auxiliary line 3 as the trigger source.
	Timer0End	Specifies to use the timer 0 end signal as the trigger source.
	Timer1End	Specifies to use the timer 1 end signal as the trigger source.
	Timer2End	Specifies to use the timer 2 end signal as the trigger source.
	Timer3End	Specifies to use the timer 3 end signal as the trigger source.
	Counter0End	Specifies to use the counter 0 end signal as the trigger source.
	Counter1End	Specifies to use the counter 1 end signal as the trigger source.
	Counter2End	Specifies to use the counter 2 end signal as the trigger source.
	Counter3End	Specifies to use the counter 3 end signal as the trigger source.
	Encoder0	Specifies to use encoder interface 0 output signal as the trigger source.
Timer0Start	Specifies to use the timer 0 start signal as the trigger source.	
Timer1Start	Specifies to use the timer 1 start signal as the trigger source.	
Timer2Start	Specifies to use the timer 2 start signal as the trigger source.	
Timer3Start	Specifies to use the timer 3 start signal as the trigger source.	
Counter0Start	Specifies to use the counter 0 start signal as the trigger source.	

Feature name	Description	
	Feature value	Description
TimerTriggerSource [TimerSelector] (Continued)...	Counter1Start	Specifies to use the counter 1 start signal as the trigger source.
	Counter2Start	Specifies to use the counter 2 start signal as the trigger source.
	Counter3Start	Specifies to use the counter 3 start signal as the trigger source.
	LogicBlock0	Specifies to use the logic block 0 output signal as the trigger source.
	LogicBlock1	Specifies to use the logic block 1 output signal as the trigger source.
	LogicBlock2	Specifies to use the logic block 2 output signal as the trigger source.
	LogicBlock3	Specifies to use the logic block 3 output signal as the trigger source.
	UserOutput0	Specifies to use the user output register bit 0 signal as the trigger source.
	UserOutput1	Specifies to use the user output register bit 1 signal as the trigger source.
TimerTriggerActivation [TimerSelector]	Sets the activation mode of the trigger signal that starts the timer. Note that if a delay has been specified, the delay is applied after the reception of the trigger before starting the timer trigger. By default, this feature is set to RisingEdge .	
	RisingEdge	Specifies to start the timer counting upon a rising edge (low-to-high transition) of the trigger signal.
	FallingEdge	Specifies to start the timer counting upon a falling edge (high-to-low transition) of the trigger signal.
	AnyEdge	Specifies to start the timer counting upon a rising or falling edge of the trigger signal.
	LevelLow	Specifies to start the timer count as long as the level of the trigger signal is low.
	LevelHigh	Specifies to start the timer count as long as the level of the trigger signal is high.

Logic Block Control

The **Logic Block Control** category groups features that control the user-configurable logic blocks. A logic block applies a specified combinational logic operation (for example, AND) on the specified input signals to generate an output signal. The output signal can be used in other modules as a source (for example, trigger source).

Feature name	Description	
	Feature value	Description
LogicBlockSelector	Sets which logic block to control.	
	LogicBlock0	Specifies to control logic block 0. Note that when using the Multi-Altiz Plugin, LogicBlockSelector is set to LogicBlock0 .
	LogicBlock1	Specifies to control logic block 1.
	LogicBlock2	Specifies to control logic block 2.
	LogicBlock3	Specifies to control logic block 3.
LogicBlockFunction [LogicBlockSelector]	Sets the combinational logic function of the logic block. By default, this feature is set to AND .	
	AND	Specifies to apply an AND operation to all inputs of the logic block.
	OR	Specifies to apply an OR operation to all inputs of the logic block.
	LUT	Specifies to apply a lookup table transformation operation to all inputs of the logic block.
	LatchedLUT	Specifies to apply two lookup tables as inputs to a flip-flop logical operation.
LogicBlockLUTSelector [LogicBlockSelector]	Sets which of the two LUTs to configure when the selected logic block's function is set to LatchedLUT .	
	Value	Specifies the LUT controlling the data input of the flip-flop.
	Enable	Specifies the LUT controlling the enabled input of the flip-flop.
LogicBlockInputNumber [LogicBlockSelector] [LogicBlockLUTSelector]	Returns the number of active signal inputs of the logic block. This feature is read only.	
LogicBlockInputSelector [LogicBlockSelector]	Sets which logic block input to configure.	
	0	Specifies to configure logic block input 0.
	1	Specifies to configure logic block input 1.
	2	Specifies to configure logic block input 2.

Feature name	Description	
	Feature value	Description
LogicBlockInputSource [LogicBlockSelector] [LogicBlockInputSelector]	Sets the source signal for the selected input of the selected logic block. By default, this feature is set to False .	
	False	Specifies that the input to the logic block will be forced off.
	True	Specifies that the input to the logic block will be forced on.
	AcquisitionActive	Specifies to use the acquisition active signal as the source signal for the input to the logic block. Note that when using the Multi-AltIZ Plugin, AcquisitionActive is set by default.
	ExposureActive	Specifies to use the exposure active signal as the source signal for the input to the logic block.
	SoftwareSignal0	Specifies to use software signal 0, generated using the SoftwareSignalPulse command, as the source signal for the input to the logic block.
	SoftwareSignal1	Specifies to use software signal 1, generated using the SoftwareSignalPulse command, as the source signal for the input to the logic block.
	SoftwareSignal2	Specifies to use software signal 2, generated using the SoftwareSignalPulse command, as the source signal for the input to the logic block.
	SoftwareSignal3	Specifies to use software signal 3, generated using the SoftwareSignalPulse command, as the source signal for the input to the logic block.
	Line0	Specifies to use auxiliary line 0 as the source signal for the input to the logic block.
	Line1	Specifies to use auxiliary line 1 as the source signal for the input to the logic block.
	Line2	Specifies to use auxiliary line 2 as the source signal for the input to the logic block.
	Line3	Specifies to use auxiliary line 3 as the source signal for the input to the logic block.
	Encoder0	Specifies to use the encoder interface 0 output signal as the source signal for the input to the logic block.
	Timer0Active	Specifies to use the timer 0 active signal as the source signal for the input to the logic block.
	Timer1Active	Specifies to use the timer 1 active signal as the source signal for the input to the logic block.
	Timer2Active	Specifies to use the timer 2 active signal as the source signal for the input to the logic block.
Timer3Active	Specifies to use the timer 3 active signal as the source signal for the input to the logic block.	
Counter0Active	Specifies to use the counter 0 active signal as the source signal for the input to the logic block.	

Feature name	Description	
	Feature value	Description
LogicBlockInputSource [LogicBlockSelector] [LogicBlockInputSelector] (Continued)...	Counter1Active	Specifies to use the counter 1 active signal as the source signal for the input to the logic block.
	Counter2Active	Specifies to use the counter 2 active signal as the source signal for the input to the logic block.
	Counter3Active	Specifies to use the counter 3 active signal as the source signal for the input to the logic block.
	LogicBlock0	Specifies to use the logic block 0 output signal as the source signal for the input to the logic block.
	LogicBlock1	Specifies to use the logic block 1 output signal as the source signal for the input to the logic block.
	LogicBlock2	Specifies to use the logic block 2 output signal as the source signal for the input to the logic block.
	LogicBlock3	Specifies to use the logic block 3 output signal as the source signal for the input to the logic block.
	UserOutput0	Specifies to use the user output register bit 0 signal as the source signal for the input to the logic block.
	UserOutput1	Specifies to use the user output register bit 1 signal as the source signal for the input to the logic block.
LogicBlockInputInverter [LogicBlockSelector] [LogicBlockInputSelector]	Sets whether the logic block input source signal is inverted. This option is not available when LogicBlockInputSource is set to either True or False . By default, this feature is set to False .	
	False	Specifies not to invert the logic block input source signal.
	True	Specifies to invert the logic block input source signal.

Software Signal Control

The **Software Signal Control** category groups features that control and generate software generated signals. A software signal is a general source and can be used as a trigger signal source.

Feature name	Description	
	Feature value	Description
SoftwareSignalSelector	Sets which software signal to control.	
	SoftwareSignal0	Specifies to control software signal 0.
	SoftwareSignal1	Specifies to control software signal 1.
	SoftwareSignal2	Specifies to control software signal 2.
SoftwareSignal3	Specifies to control software signal 3.	
SoftwareSignalPulse [SoftwareSignalSelector]	Generates a pulse signal that can be used as a software trigger. This command can be used to trigger other modules that accept a SoftwareSignal as a trigger source.	

Transport Layer Control

The **Transport Layer Control** category groups features that control and provide information about the underlying transport layer (physical/software transmission standard) being used. Zebra AltiZ 4200 uses the GigeE Vision transmission standard.

Feature name	Description	
	Feature value	Description
GenDCStreamingStatus	Returns whether the current data streaming format is GenDC. This value reflects the value set for GenDCStreamingMode .	
GenDCStreamingMode	Sets the data streaming format.	
	On	Specifies that Zebra AltiZ 4200 will only stream data in the generic GenDC format.
	Off	Specifies that Zebra AltiZ 4200 will stream data in a generic packet format.
PayloadSize	Returns the number of bytes transferred for each data buffer on the stream channel. This feature is read only.	
GenDCDescriptor	Returns a preliminary GenDC descriptor that can be used as a reference for the data that is streamed out by the device. This feature is read only.	
GenDCFlowMappingTable	Returns the GenDC container data flow mapping table that will be used to transport the GenDC container. This feature is read only.	

GigE Vision Control

The **GigE Vision Control** category groups features for quickly configuring GigE Vision camera settings. **GigE Vision Control** is a subcategory of the **Transport Layer Control** category.

Feature name	Description	
	Feature value	Description
GevSCSPacketSize	Sets the maximum stream packet size, in bytes, supported by the GigE Vision Streaming Protocol (GVSP) receiver (the application receiving data from Zebra Altiz 4200). Typically, the packet size is automatically negotiated with the receiving application; this feature allows the receiving application to override the size. Note this feature is for advanced users. Setting this feature incorrectly can cause errors.	
GevSCPD	Sets the delay (in GEV timestamp counter units) to insert between each packet. This can be used as a crude flow-control mechanism if the application or the network infrastructure cannot keep up with the packets coming from the device.	
GevMACAddress	Returns the MAC address of the logical link of your Zebra Altiz 4200.	
GevCurrentIPConfigurationLLA	Returns whether the link local address (LLA) IP configuration scheme is activated on the logical link.	
	On	Specifies that LLA is activated on the logical link.
	Off	Specifies that LLA is not activated on the logical link.
GevCurrentIPConfigurationDHCP	Sets whether the DHCP IP configuration scheme is activated on the logical link.	
	On	Specifies that DHCP is activated on the logical link.
	Off	Specifies that DHCP is not activated on the logical link.
GevCurrentIPConfigurationPersistentIP	Sets whether the PersistentIP configuration scheme is activated on the logical link	
	On	Specifies that PersistentIP is activated on the logical link.
	Off	Specifies that PersistentIP is not activated on the logical link.
GevCurrentIPAddress	Returns the IP address for the logical link.	
GevCurrentSubnetMask	Returns the subnetmask of the logical link.	
GevCurrentDefaultGateway	Returns the default gateway IP address of the logical link.	
GevIPConfigurationStatus	Returns the current IP configuration status.	
	PersistentIP	Specifies that the current IP configuration is PersistentIP.
	DHCO	Specifies that the current IP configuration is DHCO.
	LLA	Specifies that the current IP configuration is LLA.
	ForceIP	Specifies that the current IP configuration is ForceIP.

Test Control

The **Test Control** category groups features that control and provide information about the test payload format.

Feature name	Description	
	Feature value	Description
TestEventGenerate	Generates a test event. This feature is write only.	
TestPayloadFormatMode	Sets the test mode for Zebra Altiz 4200 and outputs a specific payload format that is used for validating the streaming data. This feature is intended solely for testing purposes.	
	GenDC	Specifies that Zebra Altiz 4200 will stream using GenDC payload format, with at least one component in each payload.
	Off	Specifies that Zebra Altiz 4200 will not stream a test payload and instead will stream data according to its configuration.

Event Control

The **Event Control** category groups features that control and provide information about the acquisition or trigger events.

Feature name	Description	
	Feature value	Description
EventSelector	Sets the type of event for which to configure whether an event notification will be triggered.	
	AcquisitionError	Specifies that Zebra Altiz 4200 has encountered an acquisition error.
	LineTriggerMissed	Specifies that Zebra Altiz 4200 has missed a line trigger.
EventNotification [EventSelector]	Sets whether an event notification will be triggered.	
	Off	Specifies that event notification is disabled.
	On	Specifies that event notification is enabled.

Event Acquisition Error Data Control

The **Event Acquisition Error Data Control** category groups features that return data about an acquisition error event. **Event Acquisition Error Data Control** is a subcategory of the **Event Control** category.

Feature name	Description
EventAcquisitionError	Returns the unique identifier of the acquisition error event.
EventAcquisitionErrorTimestamp	Returns the timestamp of the acquisition error event.
EventAcquisitionErrorFrameID	Returns the frame ID of the acquisition error event.

Event Acquisition Trigger Missed Control

The **Event Acquisition Trigger Missed Control** category groups features that return data about an acquisition trigger missed event. **Event Acquisition Trigger Missed Control** is a subcategory of the **Event Control** category.

Feature name	Description
EventLineTriggerMissed	Returns the unique identifier of the line trigger missed event.
EventLineTriggerMissedTimestamp	Returns the timestamp of the line trigger missed event.
EventLineTriggerMissedFrameID	Returns the frame ID of the line trigger missed event.

Event Test Data Control

The **Event Test Data Control** category groups features that return data about a test data event generated using **TestEventGenerate** command. **Event Test Data Control** is a subcategory of the **Event Control** category.

Feature name	Description
EventTest	Returns the unique identifier of the test event generated using the TestEventGenerate command.
EventTestTimestamp	Returns the timestamp of the test event generated using the TestEventGenerate command.

Chunk Data Control

The **Chunk Data Control** category groups features that control and provide information about chunk data. Chunk data is extra information that Zebra AltiZ 4200 can transmit with each transmitted scan. To access the data of the chunk associated with a feature, prefix the feature name with *Chunk* (for example, *ChunkFeatureName*).

Feature name	Description	
	Feature value	Description
ChunkModeActive	Sets whether to enable the transmission of chunk data.	
	True	Specifies that chunk data mode is enabled.
	False	Specifies that chunk data mode is disabled.
ChunkSelector	Sets which feature's chunk mode to control when setting the ChunkEnable feature.	
	Scan3dAll	Specifies to control the chunk mode of all the Scan 3D Control features whose values can be transmitted as chunk data (see below).
	EncoderAll	Specifies to control the chunk mode of all the Encoder Control features whose value can be transmitted as chunk data (see below).
	FrameID	Specifies to control the chunk mode of the FrameID feature.
	Scan3dDistanceUnit	Specifies to control the chunk mode of the Scan3dDistanceUnit feature.
	Scan3dCoordinateSystem	Specifies to control the chunk mode of the Scan3dCoordinateSystem feature.
	Scan3dCoordinateOutputMode	Specifies to control the chunk mode of the Scan3dCoordinateOutputMode feature.
	ScanCoordinateSystemAnchorMode	Specifies to control the chunk mode of the Scan3dCoordinateSystemAnchorMode feature.
	Scan3dCoordinateSystemReference	Specifies to control the chunk mode of the Scan3dCoordinateSystemReference feature.
Scan3dCoordinateScale	Specifies to control the chunk mode of the Scan3dCoordinateScale feature.	

Feature name	Description	
	Feature value	Description
ChunkSelector (Continued)...	Scan3dCoordinateOffset	Specifies to control the chunk mode of the Scan3dCoordinateOffset feature.
	Scan3dAxisMin	Specifies to control the chunk mode of the Scan3dAxisMin feature.
	Scan3dAxisMax	Specifies to control the chunk mode of the Scan3dAxisMax feature.
	Scan3dInvalidDataFlag	Specifies to control the chunk mode of the Scan3dInvalidDataFlag feature.
	Scan3dInvalidDataValue	Specifies to control the chunk mode of the Scan3dInvalidDataValue feature.
	Scan3dCoordinateTransformValue	Specifies to control the chunk mode of the Scan3dCoordinateTransformValue feature.
	Scan3dCoordinateReferenceValue	Specifies to control the chunk mode of the Scan3dCoordinateReferenceValue feature.
	EncoderValue	Specifies to control the chunk mode of the EncoderValue feature.
	EncoderStatusValue	Specifies to control the chunk mode of the EncoderStatusValue feature.
ChunkEnable [ChunkSelector]	Sets whether to enable the chunk mode of the selected feature. When enabled, the value of the feature is transmitted as supplementary information with each transmitted scan.	
	True	Specifies that the chunk mode of the selected feature is enabled.
	False	Specifies that the chunk mode of the selected feature is disabled.
ChunkFrameID	Returns the unique identifier of the 3D data included in the payload.	
ChunkScan3dDistanceUnit	Returns the real world units used when establishing the coordinates/depths of the 3D data included in the payload. For Zebra Altiz 4200, the only possible return value is mm .	
ChunkScan3dCoordinateSystem	Returns the type of coordinate system used to express the 3D data included in the payload. For Zebra Altiz 4200, the only coordinate system available is Cartesian (XYZ coordinates).	
ChunkScan3dOutputMode	Returns the mode in which the 3D data, included in the payload, has been outputted.	
	CalibratedABC_Grid	Specifies that the 3D data is being output in a point cloud format.
	RectifiedC	Specifies that the 3D data is being output in depth map format.

Feature name	Description	
	Feature value	Description
ChunkScan3dCoordinateSystemAnchorMode	Returns the Anchor coordinate system mode used to establish the 3D data in the payload. The mode establishes the position and orientation of the Anchor coordinate system.	
	Distance	Specifies that the origin of the Anchor coordinate system, when facing the connectors of Zebra Altiz 4200, is at the near FoV aligned with the left edge of the far FoV. In this mode, the orientation matches the Y-Z reference mark (on the body of Zebra Altiz 4200). In this mode, all X and Z-coordinates are positive.
	Height	Specifies that the origin of the Anchor coordinate system, when facing the connectors of Zebra Altiz 4200, is to the left edge of the far FoV, and at the beginning of the far FoV. In this mode, the orientation of the Z-axis points towards the body of Zebra Altiz 4200, with the Y-axis pointing in the opposite direction from the Y-Z reference mark. In this mode, all X and Z-coordinates are positive.
ChunkScan3dCoordinateSystemReference	ReferencePoint	Specifies that the origin of the Anchor coordinate system is approximately located at the Y-Z reference mark, with the X-coordinate centered along the width of the body. The orientation matches the Y-Z reference mark. In this mode, X-coordinates can be positive or negative, and all the Z-coordinates are positive.
	Returns relative to which coordinate system the coordinates of the 3D data, included in the payload, are expressed.	
	Anchor	Specifies that the coordinates are expressed relative to the Anchor coordinate system.
ChunkScan3dCoordinateSelector	Transformed	Specifies that the coordinates are expressed relative to the Transformed coordinate system.
	Sets the particular coordinates about which to inquire their offset or scale.	
	CoordinateA	Specifies to inquire about the X-coordinates.
ChunkScan3dCoordinateScale [ChunkScan3dCoordinateSelector]	CoordinateB	Specifies to inquire about the Y-coordinates.
	CoordinateC	Specifies to inquire about the Z-coordinates.
	Returns the scale used to convert from relative coordinates to real-world coordinates. If ChunkScan3dOutputMode is set to CalibratedABC_Grid , the scale is 1.0. This value is fixed depending on your Zebra Altiz 4200.	

Feature name	Description	
	Feature value	Description
ChunkScan3dCoordinateOffset [ChunkScan3dCoordinateSelector]	Returns the offset used to convert from relative coordinates to real world coordinates, in mm. If ChunkScan3dOutputMode is set to CalibratedABC_Grid , the offset is 0.0. This value is fixed depending on your Zebra Altiz 4200.	
ChunkScan3dAxisMin [ChunkScan3dCoordinateSelector]	Returns the minimum transmitted coordinate value of the selected coordinate of the 3D data included in the payload. This feature is available when ChunkScan3dOutputMode is set to CalibratedABC_Grid , or when ChunkScan3dOutputMode is set to RectifiedC and ChunkScan3dCoordinateSelector is set to CoordinateC .	
ChunkScan3dAxisMax [ChunkScan3dCoordinateSelector]	Returns the maximum transmitted coordinate value of the selected coordinate of the 3D data included in the payload. This feature is available when ChunkScan3dOutputMode is set to CalibratedABC_Grid , or when ChunkScan3dOutputMode is set to RectifiedC and ChunkScan3dCoordinateSelector is set to CoordinateC .	
ChunkScan3dInvalidDataFlag	Returns whether missing data/points are identified using the invalid data value (ChunkScan3dInvalidDataValue) in the range component. This feature is always set to True .	
ChunkScan3dInvalidDataValue	Returns the invalid data value that is used to identify missing data/points in the 3D data, included in the payload.	
ChunkScan3dCoordinateTransformSelector	Sets which parameter of the transformation that expresses the Transformed coordinate system, to inquire about. The transformation is relative to the Anchor coordinate system.	
	RotationX	Specifies the rotation around the X-axis.
	RotationY	Specifies the rotation around the Y-axis.
	RotationZ	Specifies the rotation around the Z-axis.
	TranslationX	Specifies the translation along the X-axis.
	TranslationY	Specifies the translation along the Y-axis.
TranslationZ	Specifies the translation along the Z-axis.	
ChunkScan3dTransformValue [ChunkScan3dCoordinateTransformSelector]	Returns the value used for the selected transformation parameter (ChunkScan3dCoordinateTransformSelector). For translations, this value corresponds to mm. For rotations, this value corresponds to degrees.	
ChunkScan3dCoordinateReferenceSelector	Sets which parameter of the transformation that expresses the Reference coordinate system, to inquire about. The transformation is relative to the Anchor coordinate system.	
	RotationX	Specifies the rotation around the X-axis.
	RotationY	Specifies the rotation around the Y-axis.
	RotationZ	Specifies the rotation around the Z-axis.
	TranslationX	Specifies the translation along the X-axis.
	TranslationY	Specifies the translation along the Y-axis.
TranslationZ	Specifies the translation along the Z-axis.	
ChunkScan3dCoordinateReferenceValue [ChunkScan3dCoordinateReferenceSelector]	Returns the value used for the selected reference parameter (ChunkScan3dCoordinateReferenceSelector). For translations, this value corresponds to mm. For rotations, this value corresponds to degrees.	

Feature name	Description	
	Feature value	Description
ChunkScanLineSelector	Sets which row (profile) of the 3D data, included in the payload, to inquire about.	
ChunkEncoderValue [ChunkScanLineSelector]	Returns the value of the encoder position counter, recorded for the selected row of the 3D data. For a multi-profile surface scan, the counter starts at the FrameStart event; for a single-profile scan, the counter starts at the LineStart event.	
ChunkEncoderStatus [ChunkScanLineSelector]	Returns the motion status of the encoder that triggered the selected row (profile).	
	EncoderIdle	Specifies that the encoder was not active.
	EncoderUp	Specifies that the encoder counter incremented (that is, the encoder moved in the forward direction).
	EncoderDown	Specifies that the encoder counter decremented (that is, the encoder moved in the backward direction).
	EncoderStatic	Specifies that the encoder has not moved within the EncoderTimeout time.
ChunkTimestampLatchValue	Returns the value of the last timestamp latched using TimestampLatch .	

File Access Control

The **File Access Control** category groups features that control and provide information about file access. These features are handled automatically by Aurora Imaging Capture Works by using the **File Access** button to easily upload and download user sets.

Feature name	Description	
	Feature value	Description
FileSelector	Sets the target files, on Zebra Altiz 4200, on which to perform an operation.	
	AllUserSets	Specifies that all of the writable user sets on the device will be downloaded or uploaded.
FileOperationSelector [FileSelector]	Sets the target operation for the selected file in the device. This operation is executed when the FileOperationExecute feature is called.	
	Open	Specifies to open the file selected by <i>FileSelector</i> in the Zebra Altiz 4200. The access mode in which the file is opened is selected by FileOpenMode.
	Close	Specifies to close the file selected by <i>FileSelector</i> in the Zebra Altiz 4200.
	Read	Specifies to read the <i>FileAccessLength</i> bytes from the Zebra Altiz 4200 at the relative offset set by <i>FileAccessOffset</i> into <i>FileAccessBuffer</i> .
	Write	Specifies to write <i>FileAccessLength</i> bytes taken from <i>FileAccessBuzzer</i> into Zebra Altiz 4200 relative to the offset set by <i>FileAccessOffset</i> .
FileOpenMode [FileSelector]	Sets the access mode in which a file is opened on the device.	
	Read	Specifies that the file is opened in read-only mode.
	Write	Specifies that the file is opened in write-only mode.
FileOperationResult [FileSelector]	Returns an integer value representing the number of bytes successfully written or read using FileOperationExecute .	
FileOperationStatus [FileSelector]	Returns the file operation execution status. Possible return values are either Success or Failure .	
FileOperationExecute	This command is reserved. To upload user sets from your computer to Zebra Altiz 4200 or to download user set files from Zebra Altiz 4200 onto your computer, you should use the File access toolbar button found in Aurora Imaging Capture Works; for information, see the Aurora Imaging Capture Works User Guide.	

Multi-Altiz Plugin Control

The **Multi-Altiz Plugin Control** category groups features that control and provide information for the 3D sensors attached in multi-altiz configuration. By default, all data saved by the Multi-Altiz Plugin (for example, alignment information) is stored in UserSet3. This cannot be modified. For information on how to setup your 3D sensors in multi-altiz configuration, see *Appendix C: Using Zebra Altiz 4200 3D sensors in multi-altiz configuration*.

Feature name	Description	
	Feature value	Description
MainCamera	Returns the user ID (DeviceUserID) of the main 3D sensor in the multi-altiz configuration topology.	
Operation	Sets whether to perform alignment. Ensure you have your alignment board created before performing alignment; for information on creating an alignment board, see <i>Create an alignment board</i> section, in <i>Appendix C: Using Zebra Altiz 4200 3D sensors in multi-altiz configuration</i> .	
	GrabOnly	Specifies that a regular grab is enabled.
	Alignment	Specifies that automatic alignment is enabled.
InstructionAndStatus	Returns the status of the alignment. This can be used when performing alignment to let you know that the 3D sensor is ready to grab. For example, you can check this status before moving a stage and initiating a grab to ensure that the 3D sensor is ready to register the movement for alignment.	
SpacingCenterToCenter	Sets the spacing, in mm along the X-axis, between the center of one circle on the alignment board and a second circle's center on the alignment board.	

Setup Control

The **Setup Control** category groups features that are used to setup multi-altiz configuration. The Setup Control category is a subcategory of the Multi-Altiz Plugin Control category.

Feature name	Description	
	Feature value	Description
AutoSaveConfig	Sets whether to save plugin settings in the main 3D sensor before each iteration of a grab. The settings are saved in all of the 3D sensors connected in multi-altiz configuration. This is enabled by default. This can slow your processing time, so understand your acquisition goals before leaving this setting enabled.	
	True	Specifies that AutoSaveConfig is enabled.
	False	Specifies that AutoSaveConfig is disabled.

Feature name	Description	
	Feature value	Description
ViewMode	Sets which grab data to display, in addition to the merged file. By default, data from all grabs is stored.	
	AllCameras	Specifies to display a merged point cloud, and the point clouds of all the 3D sensors in multi-altiz configuration.
	MergeOnly	Specifies to only display a merged point cloud.
IndividualColorPerCamera	Sets whether to assign a unique color to the point clouds grabbed by each individual 3D sensor.	
	True	Specifies that IndividualColorPerCamera is enabled.
	False	Specifies that IndividualColorPerCamera is disabled.
RefreshCameras	Sets whether to refresh the values appearing in Feature Browser by redetecting the connected 3D sensors. The configuration is also saved when this feature is executed.	
LaserMultiplexing	Sets how to control the laser delay. To set a custom laser delay, set LaserMultiplexing to Custom and set a value for LaserDelay . By default, this feature is set to Neighbour .	
	Neighbour	Specifies a laser delay synchronized with the exposure of neighboring devices, ensuring that the laser is not captured during the exposure of the previous device. This will set the delay of the neighboring Zebra Altiz 4200 to the exposure of the main Zebra Altiz 4200. This prevents data conflicts even when fields of view (FoVs) overlap.
	Off	Specifies to use no laser delay. All lasers will illuminate at once, even if the FoVs are overlapping.
	Custom	Specifies a custom laser delay.

Camera Control

The **Camera Control** category groups features that are used to set camera settings of the 3D sensors connected in multi-altiz configuration. The **Camera Control** category is a subcategory of the **Multi-Altiz Plugin Control** category.

Feature name	Description	
	Feature value	Description
Cameras	Sets which 3D sensor in the multi-altiz chain to configure. You should only be changing the settings on the main 3D sensor in the chain, but if you need to make a specific change to one of the secondary 3D sensors, you can select it using this feature. Specify the 3D sensor using its user ID (DeviceUserID).	
TopologyIndex [Cameras]	Returns the position the selected 3D sensor in the multi-altiz chain.	
Status [Cameras]	Returns the 3D sensor to which the selected 3D sensor is connected, or indicates if it is the main 3D sensor itself ("Main camera").	

Feature name	Description	
	Feature value	Description
LaserDelay [Cameras]	Sets the delay a laser will have after a grab is initiated, in ms. This is required if LaserMultiplexing is set to Custom . If LaserMultiplexing is set to Neighbour , this is automatically set.	
TranslationX [Cameras]	Sets the translation to apply to point cloud data along the X-axis, in mm. By default, this value is automatically calculated when alignment is performed, and should not be modified unless you are aware of the effect it will have on the output point cloud.	
TranslationY [Cameras]	Sets the translation to apply to point cloud data along the Y-axis, in mm. By default, this value is automatically calculated when alignment is performed, and should not be modified unless you are aware of the effect it will have on the output point cloud.	
TranslationZ [Cameras]	Sets the translation to apply to point cloud data along the Z-axis, in mm. By default, this value is automatically calculated when alignment is performed, and should not be modified unless you are aware of the effect it will have on the output point cloud.	
RotationX [Cameras]	Sets the rotation to apply to point cloud data along the X-axis, in degrees. By default, this value is automatically calculated when alignment is performed, and should not be modified unless you are aware of the effect it will have on the output point cloud.	
RotationY [Cameras]	Sets the rotation to apply to point cloud data along the Y-axis, in degrees. By default, this value is automatically calculated when alignment is performed, and should not be modified unless you are aware of the effect it will have on the output point cloud.	
RotationZ [Cameras]	Sets the rotation to apply to point cloud data along the Z-axis, in degrees. By default, this value is automatically calculated when alignment is performed, and should not be modified unless you are aware of the effect it will have on the output point cloud.	

Chapter

6

Using Zebra Altiz 4200 with Aurora Imaging Library

This chapter provides an overview of how to setup Zebra Altiz 4200 using Aurora Imaging Library.

Configuring Zebra AltiZ 4200 using Aurora Imaging Library

You can configure Zebra AltiZ 4200 using either a user interface such as Aurora Imaging Capture Works, or by programming Zebra AltiZ 4200 manually (for example, using Aurora Imaging Library).

To inquire and control the GenICam standard and custom features of your Zebra AltiZ 4200 using Aurora Imaging Library, perform the following:

1. Allocate an Aurora Imaging Library application context, an Aurora Imaging Library GigE Vision system, a digitizer, and buffers, according to the needs of your Aurora Imaging Library application.

In the case where you have multiple GigE Vision cameras or 3D sensors on your network, you can allocate a digitizer for a specific Zebra AltiZ 4200 using **MdigAlloc()** with the **M_GC_CAMERA_ID** macro, specifying either its name or its IP address.

2. Use **MdigInquireFeature()** to inquire the current value of the required feature.
3. If a Zebra AltiZ 4200 feature is not already set to the required value, call **MdigControlFeature()** to change the value of the feature.
4. When all operations are complete, free your Aurora Imaging Library buffers, digitizer(s), Aurora Imaging Library GigE Vision system, and Aurora Imaging Library application context.

There are Aurora Imaging Library examples that you can reference to perform basic functions. Some useful examples to reference for Zebra AltiZ 4200, include:

- To enumerate the current value of the features of Zebra AltiZ 4200, see the **EnumFeatures.cpp** example.
- To enable chunk data, see the **ChunkMode.cpp** example.
- To perform basic 3D acquisition using Zebra AltiZ 4200, see the **MdigProcess3D.cpp** example.

Appendix A:

Glossary

This appendix defines some of the specialized terms used in this manual.

Glossary

- **802.3af**

802.3af is a PoE standard that allows up to 15.4 W of DC power from the *power sourcing equipment* (PSE) side, resulting in a maximum power consumption of 12.95 W at the *powered device* (PD) side.

- **802.3at**

802.3at is a PoE+ standard that allows up to 30 W of DC power from the *power sourcing equipment* (PSE) side, resulting in a maximum power consumption of 25.5 W at the *powered device* (PD) side.

- **Anchor coordinate system**

The Anchor coordinate system is a Cartesian coordinate system with its position and orientation set according to the selected Anchor coordinate system mode. By default, Zebra AltiZ 4200 returns coordinates relative to the Anchor coordinate system. Most GenICam features that you set for Zebra AltiZ 4200 are also relative to the Anchor coordinate system.

- **Auxiliary I/O signal**

See Auxiliary I/O line.

- **Auxiliary I/O line**

Also known as GPIO and discrete I/O. An auxiliary input or output line represents a physical line (pin) on which a general purpose, digital (on/off) I/O signal (auxiliary I/O signal) can be received or transmitted, respectively. An auxiliary input line can be used to receive, for example, a user-defined input signal, a trigger signal, or bit A or B of a quadrature encoder. An auxiliary output line can be used, for example, to transmit a timer active signal, a counter active signal, the output signal of the encoder interface, or a static software-controlled bit of a user output register.

- **Available Z-range**

The available Z-range is the possible range of coordinates along the Z-axis within which an image sensor can register data. This is limited by your model type.

- **Depth map**

A depth map is an image where the gray value of a pixel represents its depth in the world. Zebra AltiZ 4200 can output a single-profile scan or multi-profile surface scan in depth map format. This refers to the possibility of the range component being 1-band and storing depth information instead of explicit XYZ-coordinates. Z-coordinates are established using a Z-scale, and X and Y-coordinates are inferred from the grid of the component. If you display the range component as an image, you can infer depth from the image.

- **Motion speed**

The motion speed is the speed at which either the Zebra AltiZ 4200 is moving, or the object being scanned is moving. The scanned object can be moved by a motor driven system, such as a conveyor.

- **Multi-profile surface scan**

A multi-profile surface scan is a 3D representation of a scanned object's surface, generated by accumulating the profile of the surface along different, equidistant, sequential slices. To perform such a scan, Zebra AltiZ 4200 grabs and processes sequential images of an object as it moves underneath the laser plane. A multi-profile surface scan is transmitted as multiple rows of 3D data, whereby each row represents the profile of the object's surface along a specific slice. The scan can be output in depth map format or point cloud format.

- **PD**

Powered Device. A device that relies on the power received from a PSE. In the context of a PoE network connection, the PD is the Ethernet device endpoint that relies on the Ethernet wired network to receive its power.

- **PoE**

Power over Ethernet. PoE is a technology that allows support of power along the data lines of a wired Ethernet LAN connection.

- **Point cloud**

A point cloud is a set of 3D points representing objects in a scene. The XYZ-coordinates of the points are stored in separate bands of the range component of the scanned data; the other components store other information about each point. Together all components make up the point cloud.

- **PSE**

Power Sourcing Equipment. PSE is responsible for supplying power to the powered device. In the context of a PoE network connection, the PSE is the Ethernet device responsible for supplying power over the Ethernet wired network.

- **Resolution**

Resolution. Resolution is the amount of points per distance or the distance between points. A higher resolution is one where the quality is better and the distance between points is smaller. When expressing resolution as points per distance, a higher number means better resolution and quality; when expressing resolution as distance between points, a lower number means better resolution and quality.

- **Scan area**

The scan area refers to the region in X and Z from which to extract the profile of an object along a specific slice. This corresponds to the region in the image sensor's available field of view in which to detect the laser line on the surface of the object. If the scan area corresponds to the entire region of the available FoV, a profile can have all possible heights in the available Z-range. The scan area limits the heights (along the Z-axis) and widths (along the X-axis) that can be detected for a scanned object. Zebra AltiZ 4200 allows you to modify the size and offset of the scan area along the Z-axis. Reducing the scan area along the Z-axis reduces the grabbed laser line image size. This increases the maximum possible acquisition line rate (rate at which profiles are taken); this is useful if you need to increase scan speed or resolution. Ideally, the scan area should only correspond to your area of interest (for example, only the top of your object).

- **Scan length**

The scan length is the length of the surface to scan along the direction of motion. This includes the distance from the start of the scan (frame trigger) until the end of the object.

- **Scan step**

The scan step is the displacement between consecutive profiles.

- **Single-profile scan**

A single-profile scan is a 3D representation of a single slice of a scanned object's surface (that is, the profile of the surface along that slice). Zebra AltiZ 4200 extracts this data from up to two different images of a single laser line, taken at different angles. A single-profile scan is transmitted as a single row of 3D data, in either depth map format or point cloud format.

- **Sinking**

A sinking circuit is a DC circuit that provides the common reference (low) for the circuit. For example, Zebra AltiZ 4200 auxiliary input lines are wired as sinking input lines when their common line (AUX_ISOIND_IN_COM) is connected to 0 V; in that case, you should connect the Zebra AltiZ 4200 auxiliary input lines to devices that are sourcing the current.

- **Sourcing**

A sourcing circuit is a DC circuit that provides the voltage needed for the circuit. For example, Zebra AltiZ 4200 auxiliary input lines are wired as sourcing input lines when their common line (AUX_ISOIND_IN_COM) is connected to 24 V; in that case, you should connect the Zebra AltiZ 4200 auxiliary input lines to devices that are sinking the current.

Appendix B:

Technical reference

This appendix summarizes the hardware elements of Zebra AltiZ 4200. In addition, this appendix provides pinout descriptions for the external connectors of your Zebra AltiZ 4200.

Zebra Altiz 4200 general specifications

The image below is a simplified block diagram with an overview of the components found on all Zebra Altiz 4200 models.

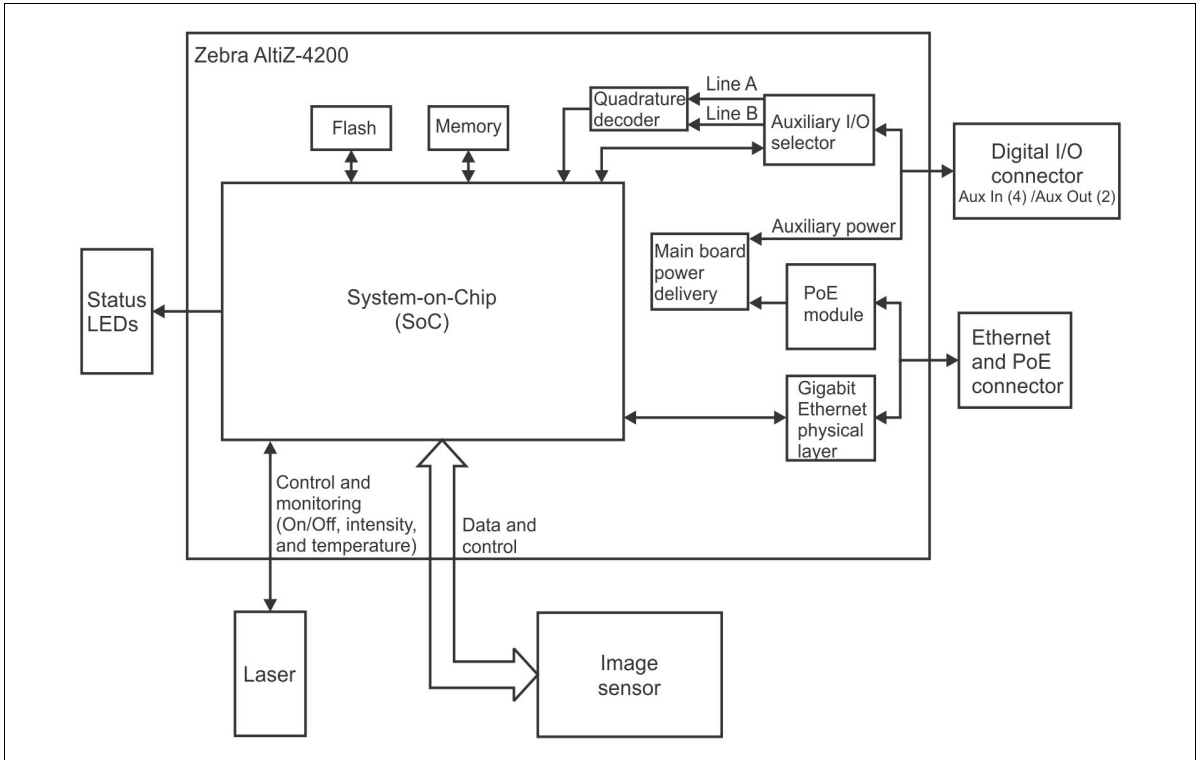

General specifications	
Available models	AZ2S-2SB, AZ2S-3SB, and AZ2S-5SB. See the <i>Models available</i> section, in <i>Chapter 1: Before you begin</i> for details.
Image sensors	9 Mpixel global shutter CMOS.
Number of image sensors	1
Effective resolution (HxV)	4224 x 2160
Pixel size (HxV)	2.5 μm x 2.5 μm
Processor	For peak extraction.
Laser	Class 3R. Wavelength range: 440-460 nm. Intensity control 0% to 100%.
Ethernet network interface	2.5 Gbps
Max ambient temperature	When using PoE, up to 40°C ^a . When using PoE+ or Zebra 4Sight EV7, up to 45°C. Automatic laser shut off when ambient temperature is over 45°C.
Profile	4200 points per profile. Maximum ROI 253 profiles per second (2160 lines) Minimum ROI 10,000 profiles per second (32 lines) ^b
Exposure	Triggered internally (programmable) or externally. Continuous or single mode. Range: 50 μsec - 250 msec.
Triggers	Source: Internal (for example, Zebra Altiz 4200 object detection or timers), external. Frequency: Single, multiple, or continuous. Controls: debounce, delay, or format (level or edge).
Auxiliary input/output lines	4 x capacitively-isolated auxiliary input lines (trigger, quadrature encoder, general purpose). 2 x opto-isolated auxiliary output lines (software configurable).
Quadrature decoder	1.5 MHz max A/B line rate (6 MHz max quadrature rate). Selectable A and B line input (uses line 0-3).
Connectors	2.5 Gbps Ethernet networking interface with M12-X 8 position connector. I/O interface with M12-A 12-position connector.
Power	PoE: Connect IEEE 802.3af compliant PSE, 44-57 Vdc, 12.95 W, maximum cable length: 30m PoE+: Connect IEEE 802.3at compliant PSE, 50-57 Vdc, 16 W, maximum cable length: 100m Auxiliary power: Connect 24 Vdc +/-10%, 0.71 A rated power supply. Priority when both auxiliary power and PoE is provided: Auxiliary power

- a. Using PoE+, Zebra 4Sight EV7, or an auxiliary power supply (24 Vdc +/-10%, 0.71 A) is required to adequately power the active cooling that is necessary for supporting a low laser temperature.
- b. There are a specific conditions that must be met to reach this value.

General specifications	
Data and control	<p>Factory calibrated.</p> <p>Compatible with most third-party processing software.</p> <p>Depth map, point cloud, or profile acquisition.</p> <p>Gigabit Ethernet connection.</p> <p>GigE Vision 2.2 compliant with (GenICam) GenDC 1.1.</p> <p>GenICam SFNC 2.6.</p>
Communication controller	PC or Zebra 4Sight EV7.
Conformity	<p>Laser safety (IEC+FDA), Electrical safety (CSA), EMC (FCC+CE),</p> <p>GenICam, GigE Vision, IEEE 802.3 Clause 33 -Power over Ethernet over 2 pairs standard with full backwards compatibility with the IEEE 802.3at and IEEE802.3af amendments, and RoHS.</p>

Electrical specifications

Zebra Altiz 4200 AZ2S-2SB, AZ2S-3SB, and AZ2S-5SB		
Operating voltage for Zebra Altiz 4200 under testing conditions		24 V
	Rated current	0.71 A
	Operating voltage tolerance	± 10%
PoE PSE: IEEE 802.3af compliant, 44-57 Vdc (+/-0%), 12.95W		
PoE+ PSE: IEEE 802.3at compliant, 50-57 Vdc (+/-0%), 16W		
Auxiliary I/O specifications		
Capacitor isolated auxiliary input lines	Operating voltage	24 V (28 V abs. max)
	Input current (sink or source)	2.8 mA max, 2.0 mA min
	ON voltage	> 11 V
	OFF voltage	< 5 V
	OFF to ON response	250 nsec (typical: 1 kHz)
	ON to OFF response	50 nsec (typical: 1 kHz)
	Minimum pulse width	250 nsec
Optically isolated auxiliary output lines	Operating voltage	24 V (28 V abs. max)
	Output current (sink or source) ^a	30 mA max
	Maximum leakage current	0.05 μA @ 26.5 V 1 mA @ 28 V
	ON voltage drop	0.6 V max @ 30 mA
	PTC ^b fuse max time-to-trip	1.5 sec @ 0.25 A
	OFF to ON response @ 30 mA	3.2 μsec when in sinking configuration 22 μsec when in sourcing configuration
	ON to OFF response @ 30 mA	20 μsec when in sinking configuration 4.5 μsec when in sourcing configuration
	Propagation time	20 μsec
	Minimum pulse width	50 μsec
	Maximum frequency	10 kHz

a. Regardless of whether the line is sinking or sourcing, this measurement is the same.

b. The PTC is an automatically resetting fuse.

Mechanical and environmental specifications

Mechanical and environmental specifications	
Environment	For indoor use only.
Maximum altitude	2000 meters.
Operating temperature	0°C to 45°C (32°F to 122°F) ^a at a non-condensing relative humidity of 10 to 90%. Using PoE+, Zebra 4Sight EV7, or an auxiliary power supply (24 Vdc +/-10%, 0.71 A) is required to power adequate active cooling for supporting a low laser temperature.
Ventilation requirements	Natural convection.
Pollution degree	2 environment.
Over-voltage category	I
International Electrotechnical Commission compliance	IEC 60068-2-6 Vibrations (stationary sinusoidal vibration) tested at 10 Hz - 150 Hz with 2 G.
	IEC 60068-2-27 Shock (Type II spectrum, half sine) tested at 15 G for 6 msec and 11 msec.
	IEC 60068-2-64 Random vibrations tests at 5 to 100 Hz with 0.5 Grms

a. Under current testing conditions.

Dimensions

Dimensions	
Weight	1.55 Kg (54.67 oz)
Zebra Altiz 4200 length	133 mm (5.24")
Zebra Altiz 4200 height, width	125 mm (4.92"), 51 mm (2")
Mounting hole diameter, depth	3.3 mm, 4 mm
Mounting hole threading	M4
Ground hole diameter, depth	2.5 mm, 4 mm
Ground hole threading	M3

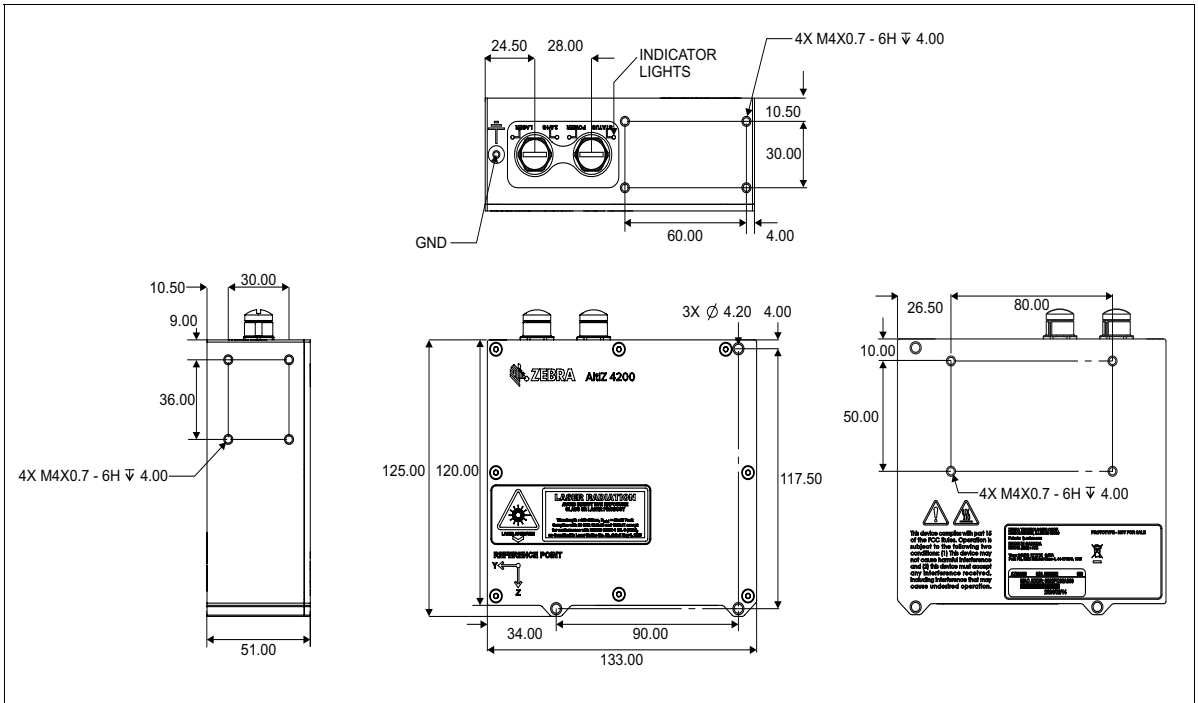

Zebra Altiz 4200 connectors

Your Zebra Altiz 4200 has two interface connectors. These are the Digital I/O and power connector and the 2.5GBASE-T Ethernet connector.

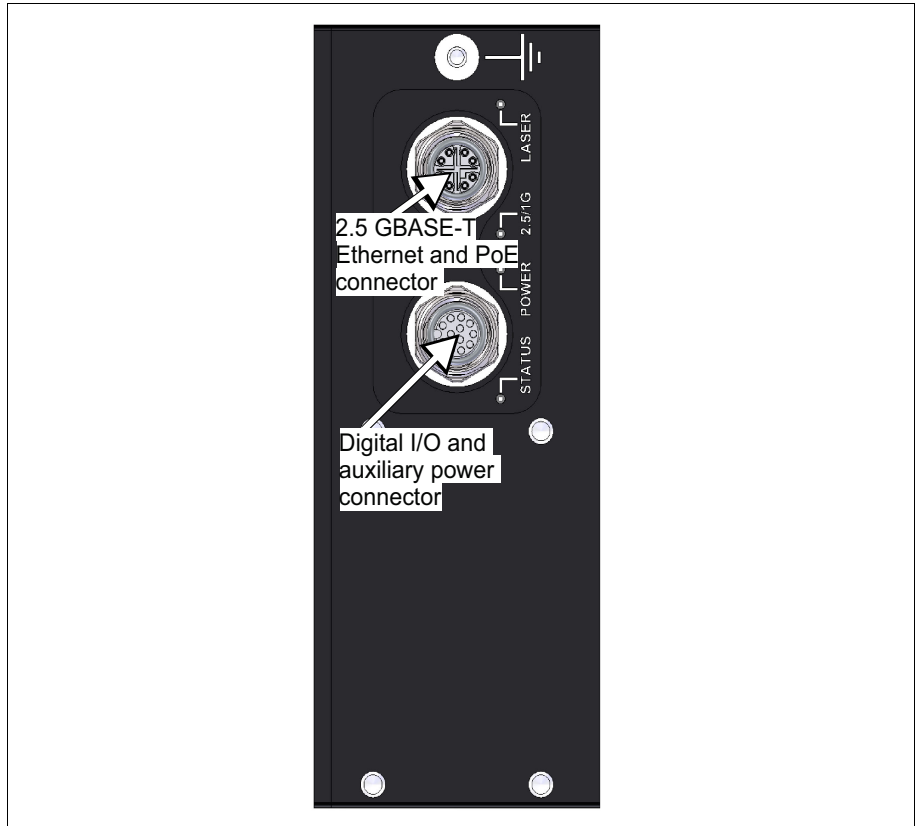

Digital I/O and power connector

The digital I/O and power connector is an M12-A 12-pin (female) connector that transmits and receives digital I/O signals and provides power to your Zebra Altiz 4200.

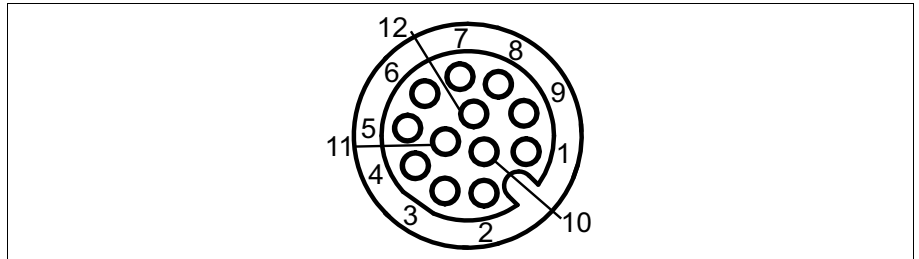

The pinout for the digital I/O and power connector is as follows:

Pin	Wire color	Hardware signal name	SFNC device name	Aurora Imaging Library constant for auxiliary lines ^a	Description
1	Brown	AUX_ISOIND_OUT_COM	N/A	N/A	Opto-isolated industrial auxiliary line (output) common.
2	Blue	AUX_ISOIND_IN2	Line2	M_AUX_IO2	Capacitively-isolated industrial auxiliary line 2 (input). Supported function: Quadrature encoder line A or B, timer input, counter input, logic block input, or user input. Note that when using the multi-altiz cable, this signal is not available to secondary Zebra Altiz 4200 3D sensors in the multi-altiz configuration.
3	White	AUX_ISOIND_OUT5	Line5	M_AUX_IO5	Opto-isolated industrial auxiliary line 5 (output). Supported function: Quadrature encoder interface output, timer output, counter output, logic block output, user output (UserOutputValue), or redirect of an input to an output.
4	Green	+ VDC	N/A	N/A	Positive pin of the power provided to Zebra Altiz 4200. This pin must be connected to a + 24 V +/-10% power supply when powering the Zebra Altiz 4200 with a power supply. If using PoE, no current flows to this pin and it does not need to be connected.
5	Pink	AUX_ISOIND_IN3	Line3	M_AUX_IO3	Capacitively-isolated industrial auxiliary line 3 (input). Supported function: Quadrature encoder line A or B, timer input, counter input, logic block input, or user input. Note that when using the multi-altiz cable, this signal is not available to secondary Zebra Altiz 4200 3D sensors in the multi-altiz configuration.
6	Yellow	AUX_ISOIND_IN_COM	N/A	N/A	Capacitively-isolated industrial auxiliary line (input) common.
7	Black	AUX_ISOIND_IN1	Line1	M_AUX_IO1	Capacitively-isolated industrial auxiliary line 1 (input). Supported function: Quadrature encoder line A or B, timer input, counter input, logic block input, or user input.

Pin	Wire color	Hardware signal name	SFNC device name	Aurora Imaging Library constant for auxiliary lines ^a	Description
8	N/A	Reserved	N/A	N/A	Reserved for future use.
9	Red	AUX_ISOIND_OUT4	Line4	M_AUX_IO4	Opto-isolated industrial auxiliary line 4 (output). Supported function: Quadrature encoder interface output, timer output, counter output, logic block output, user output (UserOutputValue), or redirect of an input to an output.
10	Violet	AUX_ISOIND_IN0	Line0	M_AUX_IO0	Capacitively-isolated industrial auxiliary line 0 (input). Supported function: Quadrature encoder line A or B, timer input, counter input, logic block input, or user input.
11	Gray-Pink	- VDC	N/A	N/A	Negative pin of the power provided to Zebra Altiz 4200. Connected to the Zebra Altiz 4200 housing. This pin must be connected to the electrical return path of the + 24 V power supply that is connected to the +VDC pin, when powering the Zebra Altiz 4200 with a power supply. If using PoE, no current flows to this pin and it does not need to be connected.
12	N/A	Reserved	N/A	N/A	Reserved for future use.

a. Note that Aurora Imaging Library documentation does not distinguish between the term "auxiliary line" and "auxiliary signal"; it only uses the term "auxiliary signal".

To interface with this connector, you can purchase a Zebra cable, M12-CBL-PWRIO/3, or you can purchase a similar cable from:

Cable information	
Manufacturer:	Phoenix Contact GmbH & Co. KG
Part number:	SAC-12P- MS/3,0-PVC SCO Order No:1554788
Description:	Sensor/actuator cable, 12-pos., black PVC, straight M12 SPEEDCON plug on free conductor end, length: 3.0 m

2.5GBASE-T Ethernet connector

The 2.5GBASE-T Ethernet connector is an M12-X (female) 8-pin connector that provides communication capabilities at 2.5 Gbit/sec.

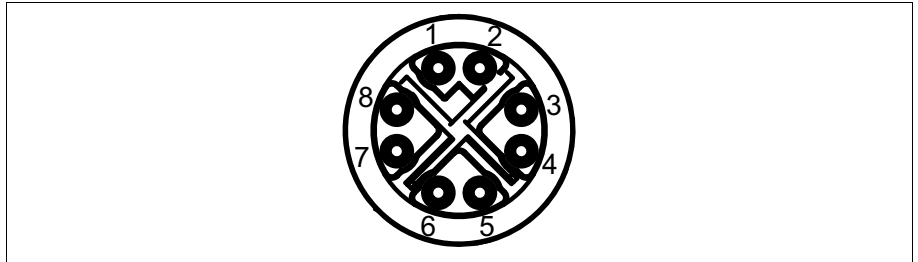

The pinout for the Ethernet connector is as follows:

Pin number	Signal name	Description
1	MDI_1+	Bidirectional data A+
2	MDI_1-	Bidirectional data A-
3	MDI_2+	Bidirectional data B+
4	MDI_2-	Bidirectional data B-
5	MDI_4+	Bidirectional data D+
6	MDI_4-	Bidirectional data D-
7	MDI_3-	Bidirectional data C-
8	MDI_3+	Bidirectional data C+

To interface with this connector, you can either purchase a Zebra cable, M12-CBL-ETH/5, or you can purchase a similar cable from:

	Cable information
Manufacturer:	Phoenix Contact GmbH & Co. KG
Part number:	NBC-MSX/5, 0-94F/R4AC SCO Order No: 1407473
Description:	Assembled Ethernet cable, CAT6A, 8-position, PUR, RAL 5021 (water blue), Plug straight M12 SPEEDCON/IP67, Coding X, on plug straight RJ45 / IP20, length 5 m.

Appendix C: Using Zebra Altiz 4200 3D sensors in multi-altiz configuration

This appendix explains how to use Zebra Altiz 4200 3D sensors in multi-altiz configuration.

Summary of multi-altiz configuration

Multi-altiz configuration is a configuration in which multiple Zebra AltiZ 4200 3D sensors are used. This is required for applications where you need to scan an object or group of objects that is too large for one single Zebra AltiZ 4200, or you require that unconnected ends of an object that are far away from one another are scanned simultaneously. The steps involved in setting up multi-altiz configuration for your Zebra AltiZ 4200 3D sensor are:

1. Mount the Zebra AltiZ 4200 3D sensors in multi-altiz configuration, as described in the *Mounting Zebra AltiZ 4200 in multi-altiz configuration* section found in this chapter.
2. Wire the Zebra AltiZ 4200 3D sensors for multi-altiz configuration. For details, see the *Wiring Zebra AltiZ 4200 in multi-altiz configuration* section found in this chapter.
3. Install and setup the plugin for multi-altiz configuration using Aurora Imaging Capture Works. For details on how to use Aurora Imaging Capture Works to install and setup the plugin, see the *Download and install the Zebra AltiZ 4200 Multi-AltiZ Plugin on your computer* section in this chapter.
4. Set the required triggers for multi-altiz configuration so that acquisition is initiated appropriately, using either Aurora Imaging Capture Works or a third party software. For details on how to use Aurora Imaging Capture Works to set the triggers, see the *Triggering in multi-altiz configuration* section found in this chapter.

Before proceeding, make sure that you can scan using a single Zebra AltiZ 4200 as described earlier in the manual. This section will explain how to mount, wire, and configure your Zebra AltiZ 4200 3D sensor to work in multi-altiz configuration. There is also an example that explains how to configure this setup using Aurora Imaging Capture Works.

Minimum requirements for Zebra Altiz 4200 multi-altiz configuration

The following lists the minimum requirements so that you can use your Zebra Altiz 4200 in multi-altiz configuration:

- Aurora Imaging Library installed to the latest version and a license for the Image Processing module.
- Aurora Imaging Capture Works installed and updated to the latest version.
- Download and install the Multi-Altiz Plugin, found on Zebra's Github page. For information on where to find the Plugin and how to install it, see *Download and install the Zebra Altiz 4200 Multi-Altiz Plugin on your computer* section in this chapter.
- Digital I/O and power cables, power supplies, and Zebra I/O Breakout Boxes for all required Zebra Altiz 4200 units.
 - ❖ Note that, if Power-over-Ethernet is used to power your Zebra Altiz 4200, power comes over the Ethernet (M12-X 8-position to RJ-45) port and not over the Zebra Altiz 4200 digital I/O and power port, which will be attached to your Zebra I/O Breakout Box.
- The required number of Zebra Altiz 4200 units.
 - ❖ Note that 6 units are the maximum number of supported Zebra Altiz 4200 units that can be connected in multi-altiz configuration.

Mounting Zebra Altiz 4200 in multi-altiz configuration

Each use case for multi-altiz configuration will differ and requires its own unique mounting considerations, but there are some basic rules to follow when mounting your Zebra Altiz 4200 in multi-altiz configuration.

- Ensure that all of the 3D sensors are facing the same direction when mounting.
- You must not have rotation around the Z-axis or rotation around the X-axis. If there is rotation around the X or Z-axis, the multi-altiz information will be invalid.

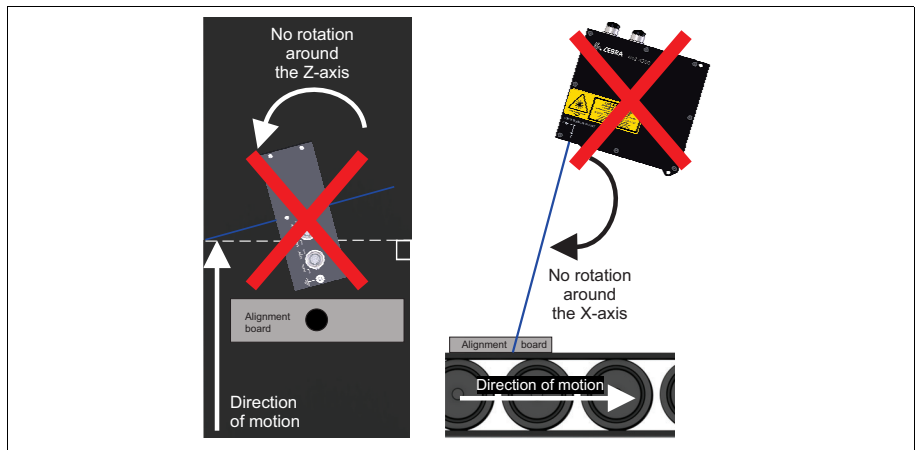

- You should use the guide pins found on the body of the Zebra Altiz 4200 to ensure the lasers of all mounted Zebra Altiz 4200 sensors are parallel. Depending on your use case, you might not need the lasers of your multi-altiz configuration to be in parallel (for example, if you are inspecting pins on opposite ends of a surface), in which case you do not need to use the guide pins.
- If you are using guide pins to ensure your 3D sensors are parallel, you should overlap some portion of the FoV of each Zebra Altiz 4200 to ensure that all points of your scanned object are captured. The exact distance you need to have between each Zebra Altiz 4200 is dependent on the Zebra Altiz 4200 model and the size of the object. The only part of the FoVs that need to overlap are those regions

where the laser line is visible; if the scanned object is tall, the mounted Zebra AltiZ 4200 3D sensors will need to be closer together so that the object falls within the near FoV of both 3D sensors.

The image below depicts possible setups for objects of different sizes.

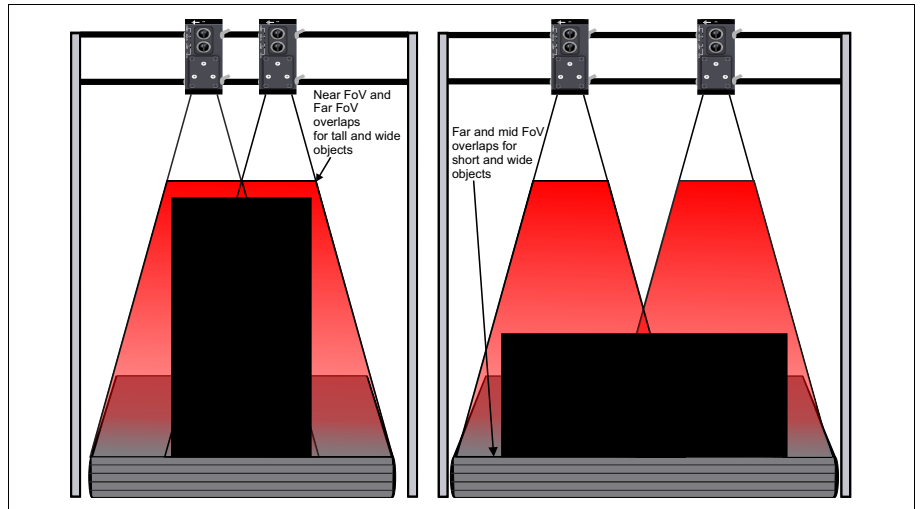

- If your use case does not require that all your Zebra AltiZ 4200 3D sensors are in parallel, you do not need to use the guide pins or overlap the laser. It is acceptable that your Zebra AltiZ 4200 sensors are mounted so they are not aligned along the Y-axis.

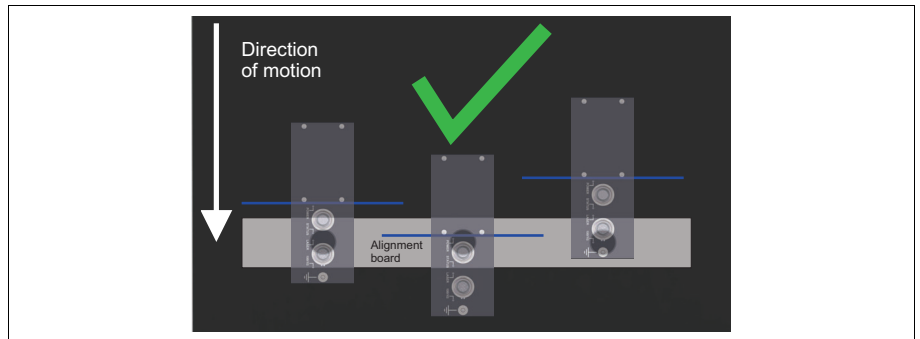

Wiring Zebra AltiZ 4200 in multi-altiz configuration

To wire your Zebra AltiZ 4200 3D sensors in multi-altiz configuration, you need to use at least one multi-altiz cable and one open wire M12 cable (M12-Y-CBL-MUL/2, and M12-CBL-PWRIO/3 respectively). These cables ensure that all 3D sensors mounted in multi-altiz configuration receive the same trigger.

When using the multi-altiz cable, the trigger is re-routed through consecutive Zebra AltiZ 4200 3D sensors in a daisy chain configuration. The main (first) Zebra AltiZ 4200 in the chain outputs the trigger input that it receives from the peripheral device (for example, a rotary encoder attached to a Zebra I/O Breakout Box), to the input of the next secondary Zebra AltiZ 4200 in the chain.

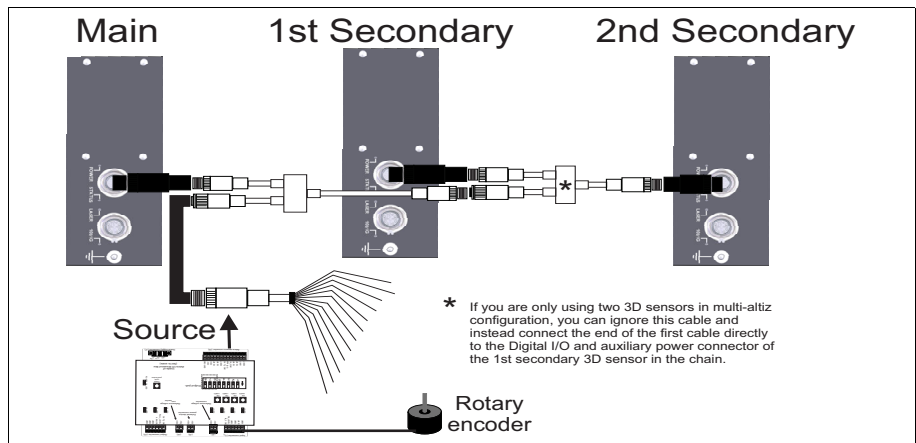

With your Zebra AltiZ 4200 3D sensors mounted for multi-altiz configuration, you will next need to power them. Since the multi-altiz cable does not provide power, you will need to individually power each 3D sensor in the multi-altiz configuration by its own PoE/Ethernet cable, connected to its 2.5 GABASE-T Ethernet and PoE connector. See the *Powering your Zebra AltiZ 4200 with PoE* section, in *Chapter 2: Powering and connecting to your Zebra AltiZ 4200* for more information.

- ❖ If you require that the connected Zebra AltiZ 4200 sensors are powered using auxiliary power instead of PoE, you cannot use the multi-altiz cable. Instead, the process for wiring multi-altiz configuration requires a Breakout Box for each 3D sensor in the multi-altiz configuration, to act as its power source. If you require this setup, please contact Zebra Technical Support for further information.

Once you have powered each of the 3D sensors in your multi-altiz configuration, you will use the multi-altiz cable and the open wire cable to connect inputs to outputs. The multi-altiz cable has three M12-A 12-pin connectors (2 male, 1 female) and the open wire cable has one M12-A 12-pin connector (male) that transmit and receive digital I/O signals to your Zebra AltiZ 4200 sensors.

The multi-altiz cable in profile and the pinout of the open wire cable can be found below:

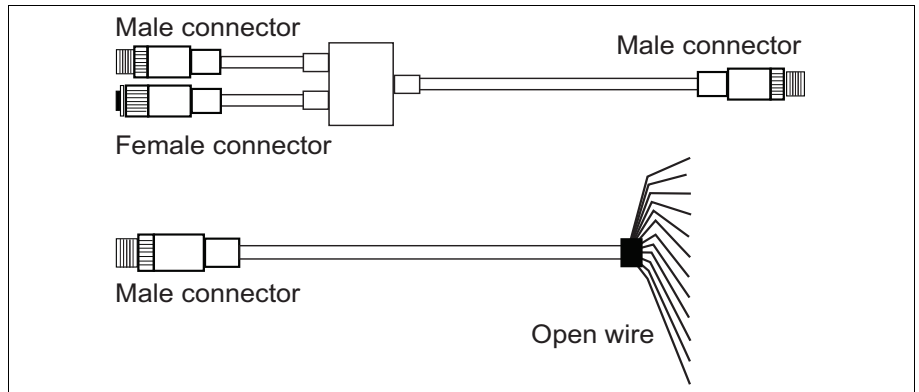

The pinout for the digital I/O and power connector is as follows:

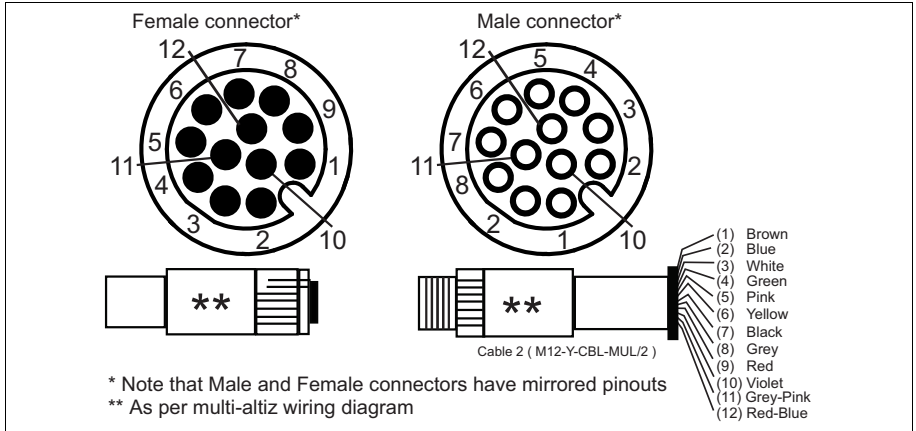

Refer to the table below to properly wire the main Zebra Altiz 4200 3D sensor to the Zebra camera connector of the I/O Breakout Box.

❖ Note that the first Zebra Altiz 4200 receives all the inputs. Then, two synchronization signals are daisy-chained to the subsequent Altiz 4200 3D sensors in the chain, using two outputs (lines 4 and 5) and received on two inputs (lines 0 and 1) of the following 3D sensors. This means that the output lines of all 3D sensors in the chain are not available for outputting data to third-party devices.

Pin	Wire color	Hardware signal name	SFNC device name	Aurora Imaging Library constant for auxiliary lines ^a	Where to connect the open-wired cable on the Zebra I/O Breakout Box camera connector (J6)
1	Brown	AUX_ISOIND_OUT_COM	N/A	N/A	Connect to I/O Breakout Box terminal 7 (OUT_COM), to provide 24 V.
2	Blue	AUX_ISOIND_IN2	Line2	M_AUX_I02	Connect to I/O Breakout Box terminal 3 (LINE2).
3	White	AUX_ISOIND_OUT5	Line5	M_AUX_I05	Connect to I/O Breakout Box terminal 9 (Line5). This line is not used.
4	Green	+ VDC	N/A	N/A	Connect to I/O Breakout Box terminal 11 (+VDC). This line is not used.

Pin	Wire color	Hardware signal name	SFNC device name	Aurora Imaging Library constant for auxiliary lines ^a	Where to connect the open-wired cable on the Zebra I/O Breakout Box camera connector (J6)
5	Pink	AUX_ISOIND_IN3	Line3	M_AUX_IO3	Connect to I/O Breakout Box terminal 4 (LINE3).
6	Yellow	AUX_ISOIND_IN_COM	N/A	N/A	Connect to I/O Breakout Box terminal 5 (IN_COM).
7	Black	AUX_ISOIND_IN1	Line1	M_AUX_IO1	Connect to I/O Breakout Box terminal 2 (LINE1).
8	Gray	Reserved	N/A	N/A	Connect to I/O Breakout Box terminal 6 (ANALOG). This line is not used.
9	Red	AUX_ISOIND_OUT4	Line4	M_AUX_IO4	Connect to I/O Breakout Box terminal 10 (LINE 4). This line is not used.
10	Violet	AUX_ISOIND_IN0	Line0	M_AUX_IO0	Connect to I/O Breakout Box terminal 1 (LINE0).
11	Gray-Pink	- VDC	N/A	N/A	Connect to I/O Breakout Box terminal 12 (-VDC).
12	Red-Blue	Reserved	N/A	N/A	Connect to I/O Breakout Box terminal 8 (LINE6). This line is not used.

- a. Note that Aurora Imaging Library documentation does not distinguish between the term "auxiliary line" and "auxiliary signal"; it only uses the term "auxiliary signal".

To connect the multi-altiz cable to multiple 3D sensors, refer to the image below and follow the step letters and numbers outlined below:

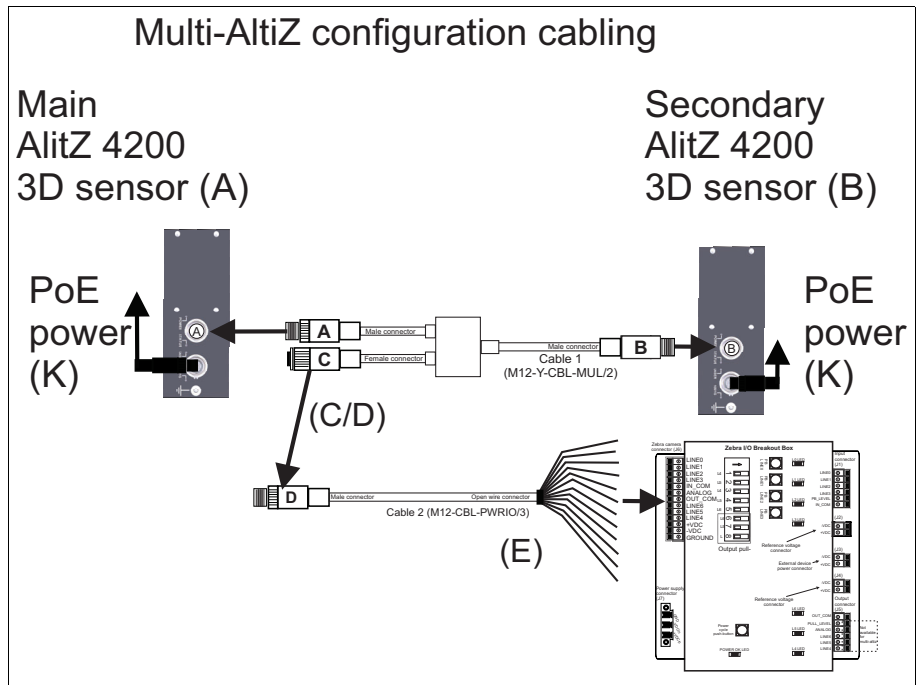

1. Connect the digital I/O and auxiliary power connector of the main 3D sensor (A) to the male connector (A) of the multi-altiz cable side with the two connectors (male and female).
2. If you are only connecting two 3D sensors, connect the unconnected male connector (B) of the multi-altiz cable attached to the main Zebra AltiZ 4200 sensor's digital I/O and auxiliary power connector to the first secondary Zebra AltiZ 4200 sensor's digital I/O and auxiliary power connector (B). The chain is complete and you can proceed to step 3.

If you are connecting more 3D sensors to the chain, instead of connecting the unconnected male connector (B) directly to the second 3D sensor in the chain (B), you will need to connect the male connector (B) to the female connector (C) of an additional multi-altiz cable and the other unconnected male connector (A) to its respective 3D sensor. Repeat this pattern for all additional secondary Zebra AltiZ 4200 sensors that you are connecting in multi-altiz configuration,

ending with the male connector of the last multi-altiz cable being connected to the digital I/O and auxiliary power connector of the last 3D sensor in the chain, as illustrated in the image below.

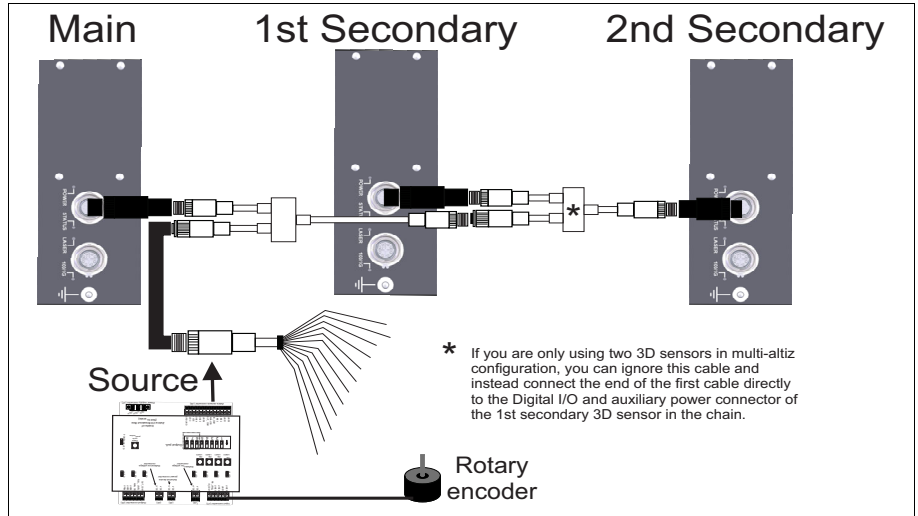

3. Attach the female connector of the first multi-altiz cable (C) to the male connector of the open wire cable (D).
4. Once the multi-altiz cable is connected both to the secondary 3D sensor in the chain, as well as the open wire cable, connect the open wire cable to the Zebra I/O Breakout Box (E).

To connect the open wire cable to the I/O Breakout Box, use the pinout table provided earlier in this section, with the diagram shown below. The open wire cable only has 12 wires (E), whereas the I/O Breakout Box Zebra camera connector (J6) has 13 wire-terminals. You can connect unused wires to the unused Zebra camera connector slots on the I/O Breakout Box to simplify wiring, but leave the ground slot open (unconnected).

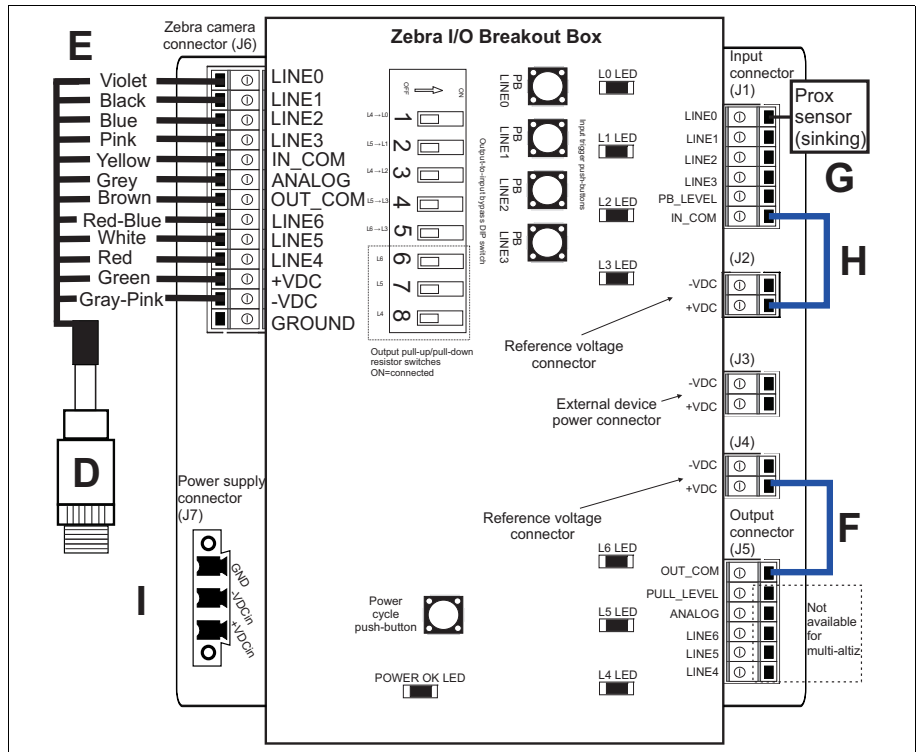

5. With the Zebra Altiz 4200 connected to the I/O Breakout Box, next you must add a jumper to the I/O Breakout Box from the +VDC slot of the J4 connector, to the OUT_COM slot of the J5 connector (F).
6. Connect your input peripheral devices to the J1 connector of the I/O Breakout Box (G). Only the main Zebra Altiz 4200 must be wired directly to the main trigger source (for example, a rotary encoder or proximity sensor). For information on the pinout of the digital I/O connector, see *Appendix B: Digital I/O and power connector*.

- Optionally, you will also use the Zebra I/O Breakout Box to dictate what type of power configuration to use with your connected 3D sensors (for example, sinking or sourcing). By default, the secondary 3D sensors connected in multi-altiz configuration are sinking power from the I/O Breakout Box, and the main 3D sensor is sourcing power to the rest of the sensors in the chain. If you need to configure the main 3D sensor to have a sinking output, add a jumper from the IN_COM slot of the J1 connector to the -VDC slot of the J2 connector (H).

Sourcing configuration below:

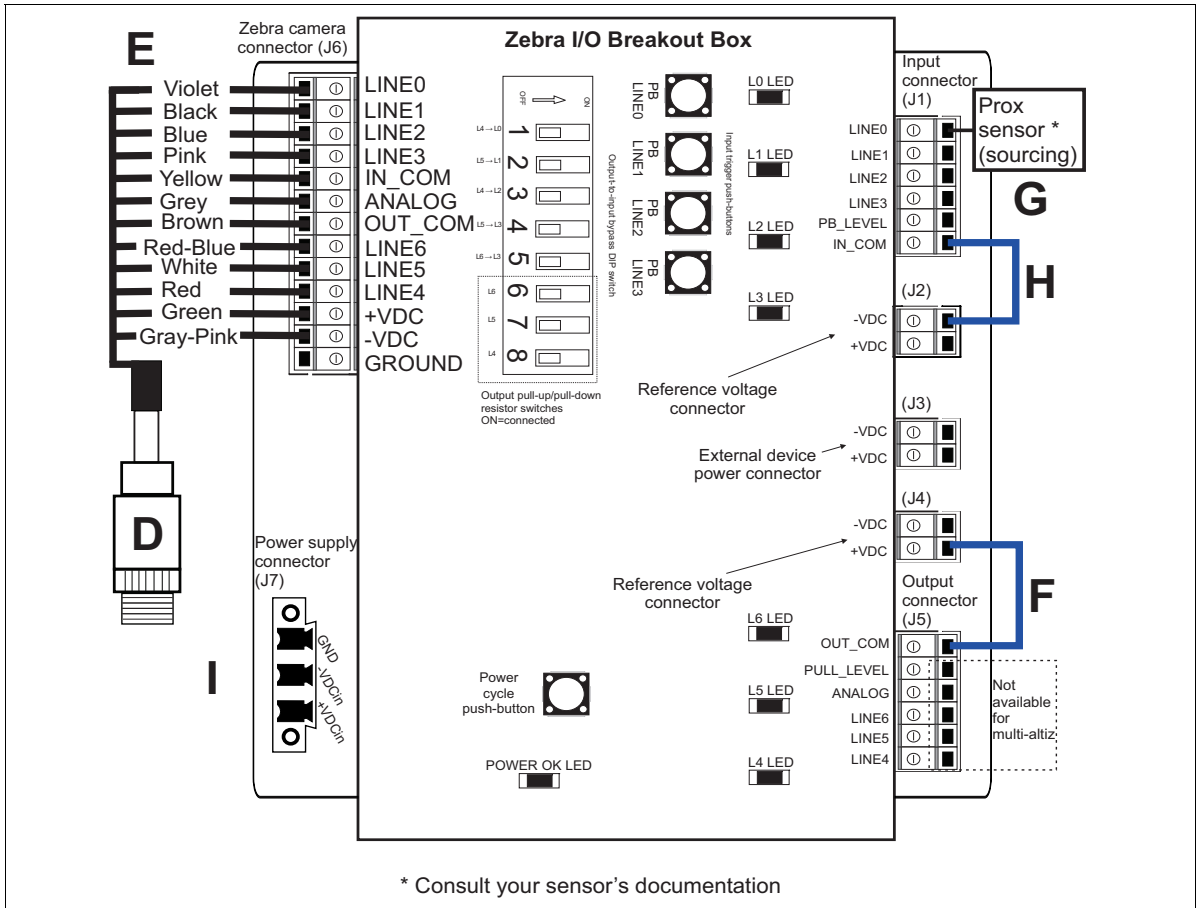

Sinking configuration below:

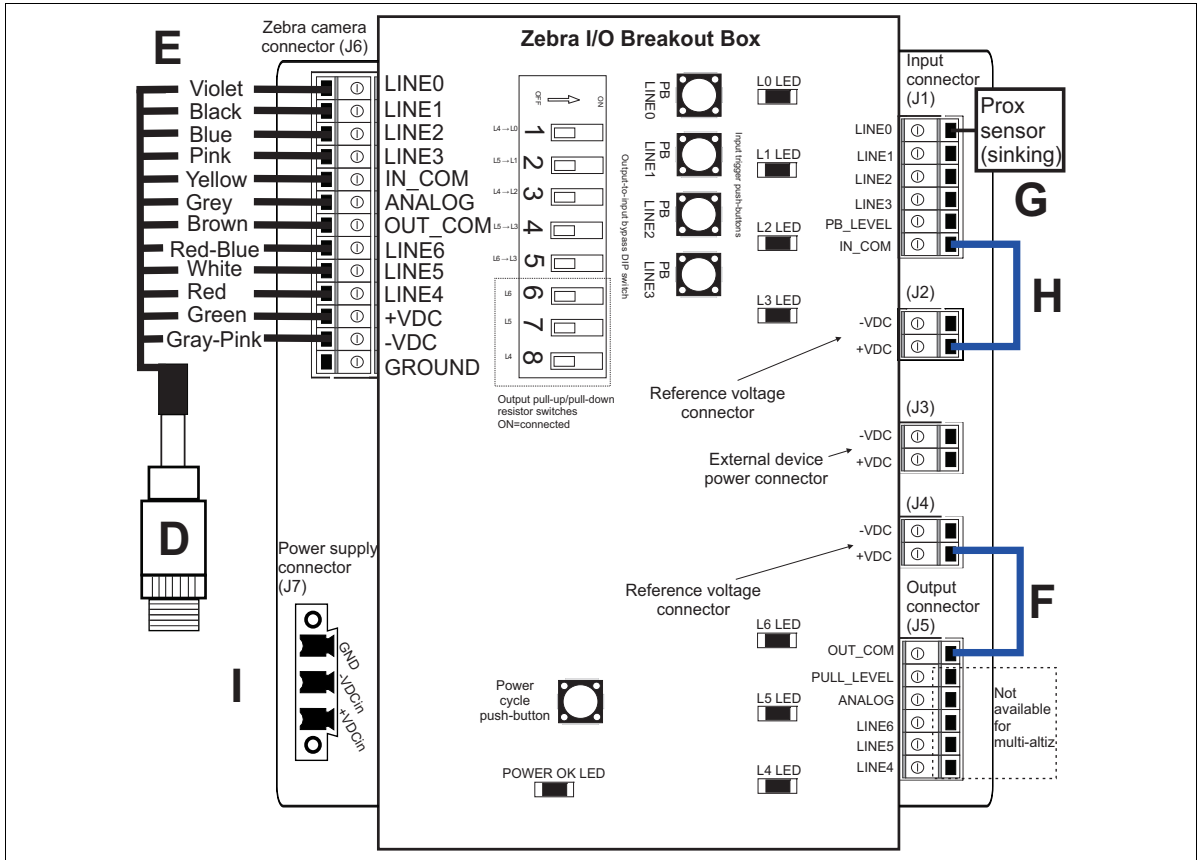

8. Power your I/O Breakout Box using the J7 power supply connector (I).
9. Connect the 2.5GBASE-T Ethernet connectors of all the Zebra Altiz 4200 sensors that are connected in multi-altiz configuration to PoE power (K). See the *Powering your Zebra Altiz 4200 with PoE* section, in *Chapter 2: Powering and connecting to your Zebra Altiz 4200* for more information.

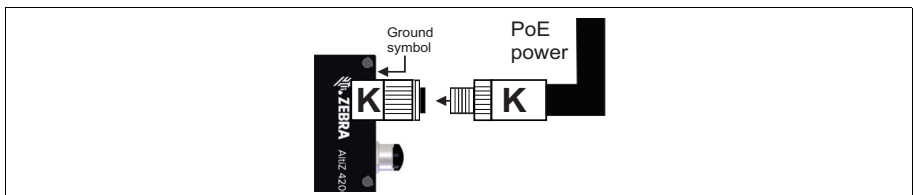

Download and install the Zebra Altiz 4200 Multi-Altiz Plugin on your computer

To download the Multi-Altiz Plugin, navigate to the Zebra github page: <https://github.com/Zebra-Aurora-Imaging-Library>. On the github page, select CaptureWorksPlugins and download the Plugin. Once the Multi-Altiz Plugin has been downloaded, unzip and install the files on the computer that is running Aurora Imaging Library and its associated software. To install the plugin files to your computer manually, copy the complete un-zipped Multi-Altiz Plugin folder to: C:\ProgramData\AuroraImaging\CaptureWorksPlugins

There is also a PowerShell Python installer, found on the Zebra github, for those familiar with Python scripts: MultiAltizInstallScript.ps1

- ❖ If you are installing the plugin using the Powershell Python installer, you will also need to install the latest version of Python. If you are using Linux, install Python version 3.6 to 3.11. If you are using Windows, install Python version 3.7, 3.9, or 3.11.

Add and setup the Zebra Altiz 4200 Multi-Altiz Plugin on Aurora Imaging Capture Works

Plugins can be added to Aurora Imaging Capture Works to increase functionality and add automation. To use the Multi-Altiz Plugin, first open Aurora Imaging Capture Works and select the Plugin manager: . With Plugin manger open, select multi-altiz, and then click on OK.

Once Plugin manager has closed, all connected Zebra Altiz 4200 units can be allocated. Ensure that you are allocating all secondary 3D sensors before allocating the main 3D sensor. Once the Zebra Altiz 4200 units are allocated, a new tab will appear:

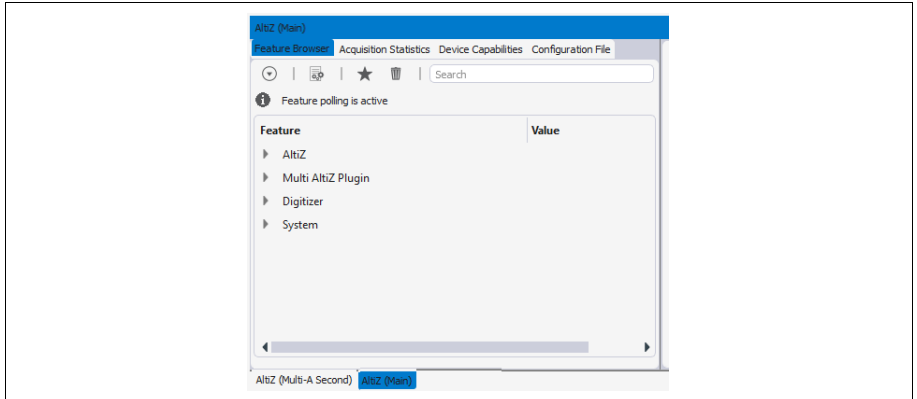

Alignment for multi-altiz configuration

When using the Multi-Altiz Plugin, `Scan3dCoordinateSystemAnchorMode` is automatically set to `ReferencePoint` and should not be modified. This will guarantee that all other sensors in the multi-altiz configuration refer to the main sensor's (0,0) position as the origin. Before you make your first acquisition, ensure that your Zebra AltiZ 4200 units are properly aligned. The Multi-Altiz Plugin does not automatically align your mounted and connected Zebra AltiZ 4200 units, and you will need to do this manually using the Multi-Altiz Plugin and an alignment board.

Create an alignment board

Before you do align, you must have an alignment board that is designed by you.

The specifications and parameter to be considered when designing your alignment board are the following:

- Use sturdy material such as wood or metal. If there is reflection to your material, either use matte paint or other methods to reduce the reflectance (for example, sandblasting).
- The length of the material should be enough to cover the length being acquired by all of the Zebra AltiZ 4200 connected in multi-altiz configuration.
- The width of the material should be enough so that a circle that is 4 cm in diameter can be cut into it.
- Cut a circle that is 4 cm in diameter into the alignment board for each connected Zebra AltiZ 4200 unit. Ensure that the distance between the center of each circle is consistent. You can see an example of what an alignment board can look like below:

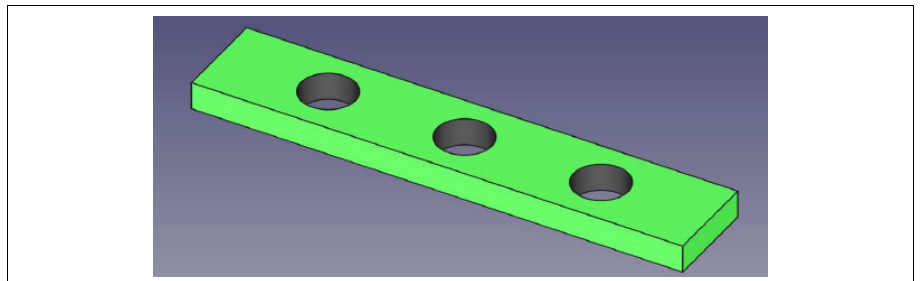

How to align your multi-altiz configuration

To align units mounted in multi-altiz configuration, perform the following:

1. Place the alignment board that you built under the 3D sensors connected in multi-altiz configuration.

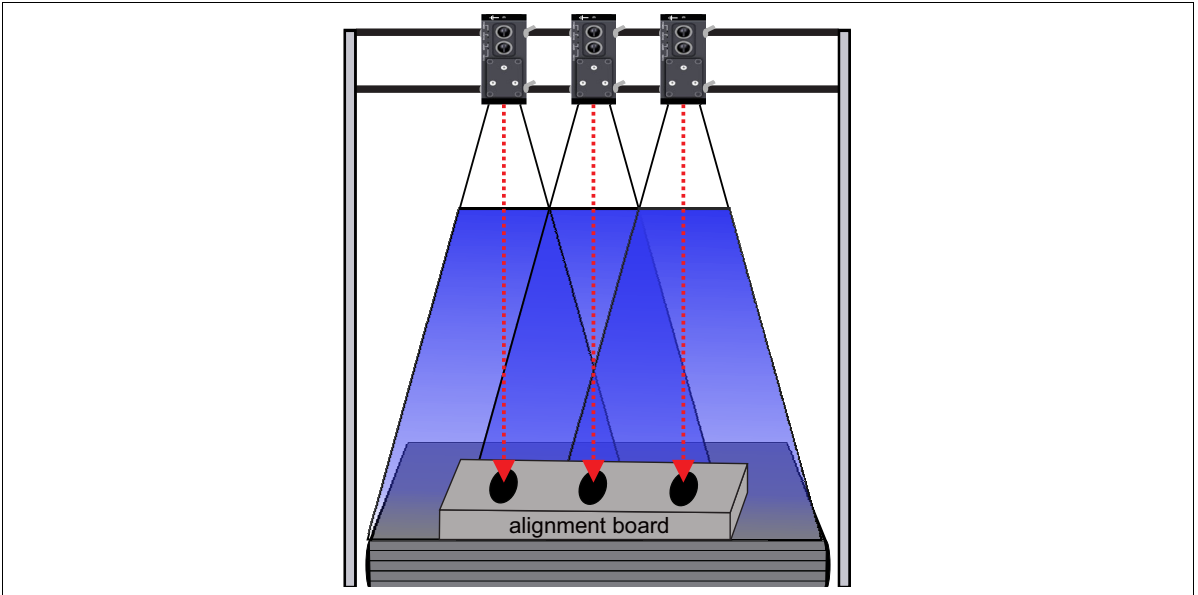

2. Position each circle under the FoV of each 3D sensor in the multi-altiz configuration. Each connected 3D sensor should have at least one circle in their FoV.
3. Align all the connected and mounted 3D sensors, beginning with the last Altiz in the chain and finishing with the first.

- Set a value for **SpacingCentertoCenter**, based on the alignment board you made using the steps mentioned in the previous section. The alignment board in the example has a **SpacingCentertoCenter** of 70 mm, between the centers of each cut circle.

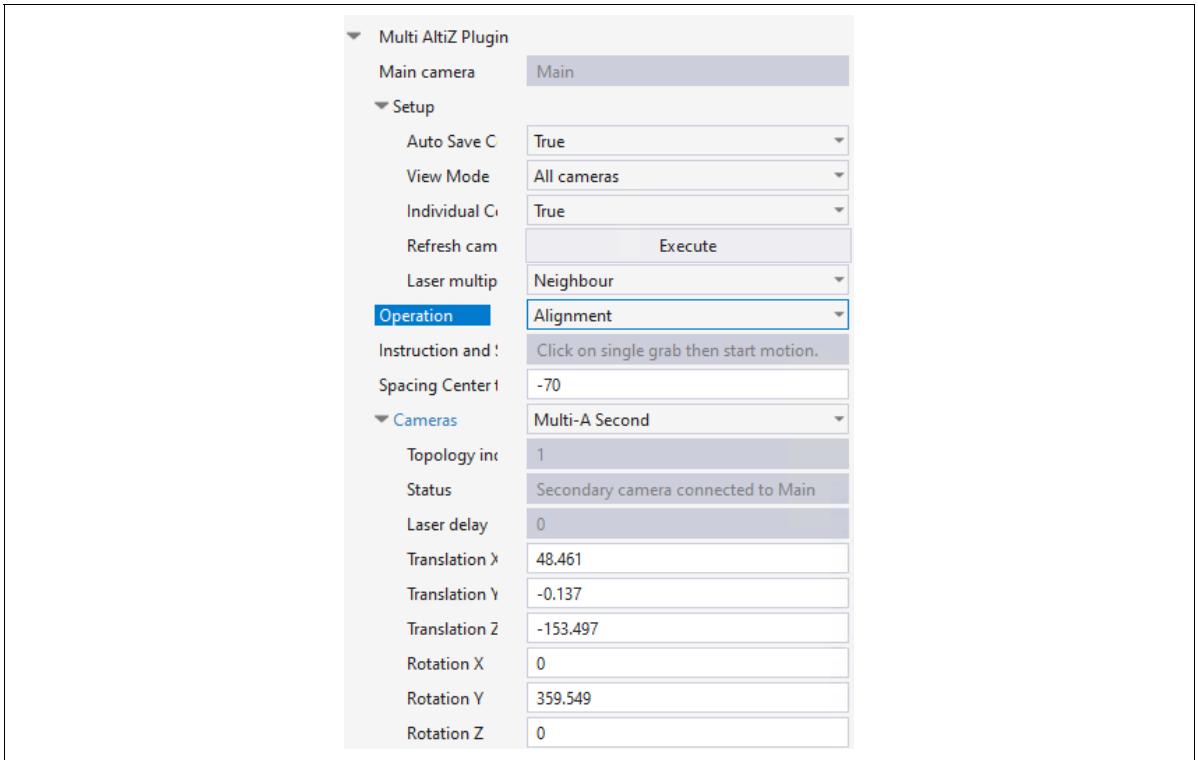

- ❖ The **SpacingCentertoCenter** feature will be positive or negative based on the direction of the X-axis of your main 3D sensor in multi-altiz configuration.
- Once the main 3D sensor is connected in multi-altiz configuration, set the **Operation** feature to **Alignment** and make a grab. The grab you take when **Operation** is set to **Alignment** produces aligned data that is used for regular scanning. Once the alignment is complete, it is recommended not to change settings in the Multi-Altiz Plugin drop down.
 - To enable regular scanning, set the **Operation** feature to **Grab**.
 - Take the alignment board off the stag and begin scanning.

Setting features in multi-altiz setup

When setting features on your Zebra AltiZ 4200 in multi-altiz configuration, the settings that you apply to the first (main) Zebra AltiZ 4200 are automatically applied to all of your secondary Zebra AltiZ 4200 units, but not the other way around. To find features related to multi-altiz configuration, open the Multi-AltiZ Plugin category in the Aurora Imaging Capture Works feature browser. For a complete list of the multi-altiz features available, see *Appendix 5: Zebra AltiZ 4200 GenICam feature reference*.

- ❖ Do not make changes from the secondary 3D sensors; this will not update the features on the other sensors, and it can cause issues with your grabs.

For initial setup, there are some settings you will need to use or be aware of:

- Make sure **LengthWorld** is long enough to account for any distance in the Y-axis of the other 3D sensor attached in multi-altiz configuration. This is worth checking if your setup is not aligned along the Y-axis.
- **AutoSaveConfiguration** is useful to save your features, but be aware that it takes processing time. The processing time can cause a delay for acquisition, which should be considered when you are using stage movement in your calibration.
- **LaserDelay** is only available on secondary units.
- **TopologyIndex** is the number of the 3D sensor in the series of 3D sensors connected in multi-altiz configuration.

For a complete list of the features available to your Zebra AltiZ 4200 sensor, see *Chapter 5: Zebra AltiZ 4200 GenICam feature reference* for more information.

Triggering in multi-altiz configuration

The first Zebra AltiZ 4200 in the chain should be setup to trigger from an external source (for example, proximity sensor or a rotary encoder), as explained in the *Setting up frame triggers for single-profile scans or multi-profile surface scans* section, in *Chapter 4: Understanding and setting the features of your Zebra AltiZ 4200*. By default, the Multi-AltiZ Plugin automatically sets certain feature values that are important for multi-altiz acquisition, and the values of these features are copied over to all secondary 3D sensors in the multi-altiz configuration. There are also a number of additional features that you need to set manually on the main 3D sensor, which are then copied over to the secondary 3D sensors. For information on the features used for multi-altiz configuration, see *Chapter 5: Zebra AltiZ 4200 GenICam feature reference*. The table below lists the features related to triggering that are automatically set by the Multi-AltiZ Plugin.

Feature name	Value set automatically by the Multi-AltiZ Plugin on the main AltiZ unit	Value set on secondary 3D sensor
Scan3dCoordinateSystemAnchorMode	ReferencePoint	Copied from main 3D sensor
LineSelector	Line4	Copied from main 3D sensor
LineSource	ExposureActive	Copied from main 3D sensor
LineSelector	Line5	Copied from main 3D sensor
LineSource	LogicBlock0	Copied from main 3D sensor
LogicBlockSelector	LogicBlock0	Copied from main 3D sensor
LogicBlockInputSource	AcquisitionActive	Copied from main 3D sensor
TriggerSelector	LineStart	Copied from main 3D sensor
TriggerSource	Encoder0	Copied from main 3D sensor
TriggerMode	On	Copied from main 3D sensor
TriggerActivation	RisingEdge	Copied from main 3D sensor

If you need to trigger using a line other than the default, you can set that manually (for example, `AUX_ISOIND_AUXIN1`), but some features should not be changed. `Scan3dCoordinateSystemAnchorMode` must remain set to `ReferencePoint`, `TriggerMode` must remain set to `On`, and `TriggerActivation` must remain set to `RisingEdge`.

Avoiding triggering conflicts

In multi-altiz configuration, Zebra AltiZ 4200 3D sensors might be mounted close enough for one Zebra AltiZ 4200 to capture the laser line of another. If the laser of one Zebra AltiZ 4200 is captured by the image sensor of the second Zebra AltiZ 4200 in the chain, this is a false reading and data that cannot be used.

To prevent your devices from registering the laser of their neighbor, set **LaserMultiplexingMode** to **Neighbour**. This feature will set a delay of the neighboring Zebra AltiZ 4200 to the exposure of the main Zebra AltiZ 4200 and is enabled by default. In this way, even if the lasers physically overlap, the device will not capture its neighbor's laser light during exposure, when properly set.

Performing a multi-profile surface scan in a multi-altiz configuration using Aurora Imaging Capture Works

Once you have performed a multi-profile surface scan at a constant line rate, and seen how to perform optimizations in *Chapter 3: Step-by-step Zebra Altiz 4200 configuration with Aurora Imaging Capture Works*, you are ready to setup your Zebra Altiz 4200 3D sensors to scan in a multi-altiz configuration.

In this example, you will be connecting two Zebra Altiz 4200 3D sensors. First, you will need to connect your auxiliary inputs to the I/O Breakout Box. Below is an example wiring a sinking sensor while powering Zebra Altiz 4200 over PoE (not shown in diagram).

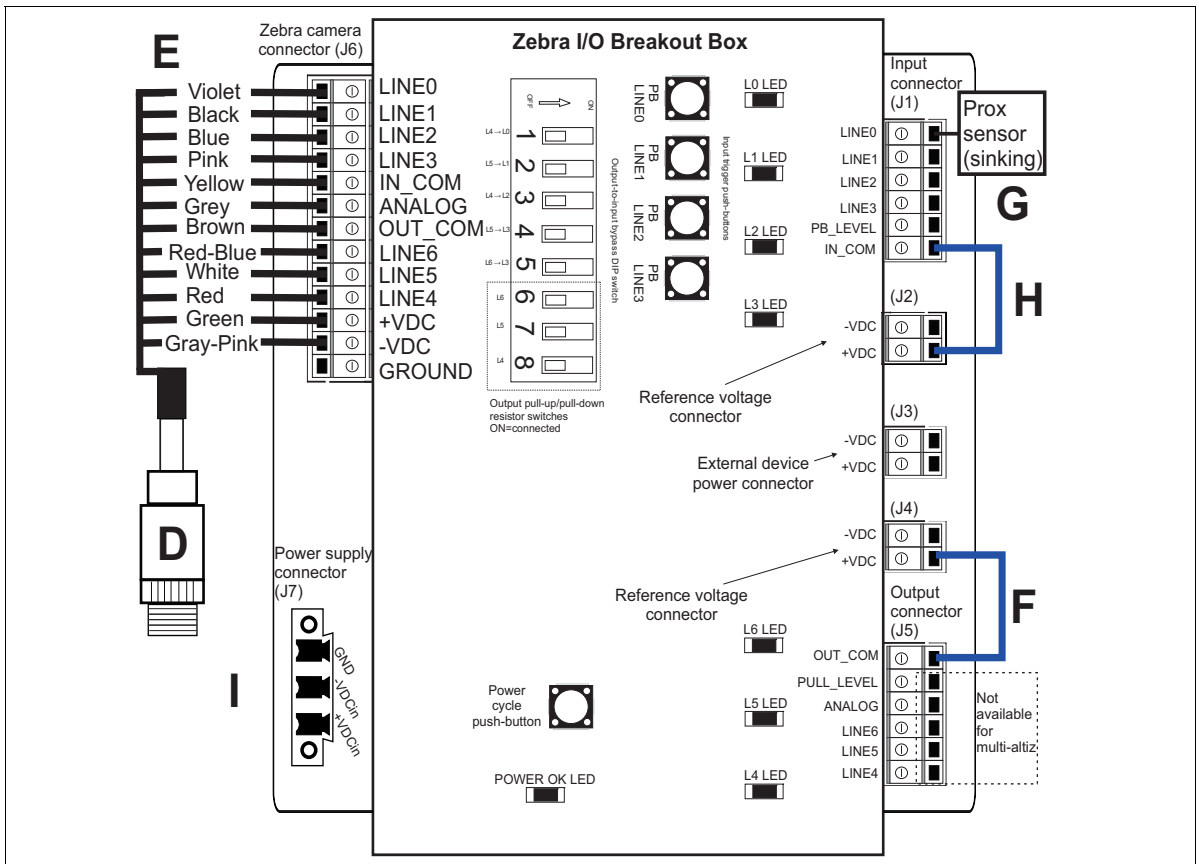

Once both Zebra AltiZ 4200 3D sensors and their peripheral devices are wired appropriately, you can begin to configure Zebra AltiZ 4200 using Aurora Imaging Capture Works. The image below shows two Zebra AltiZ 4200 units mounted, with an alignment board placed underneath for scanning.

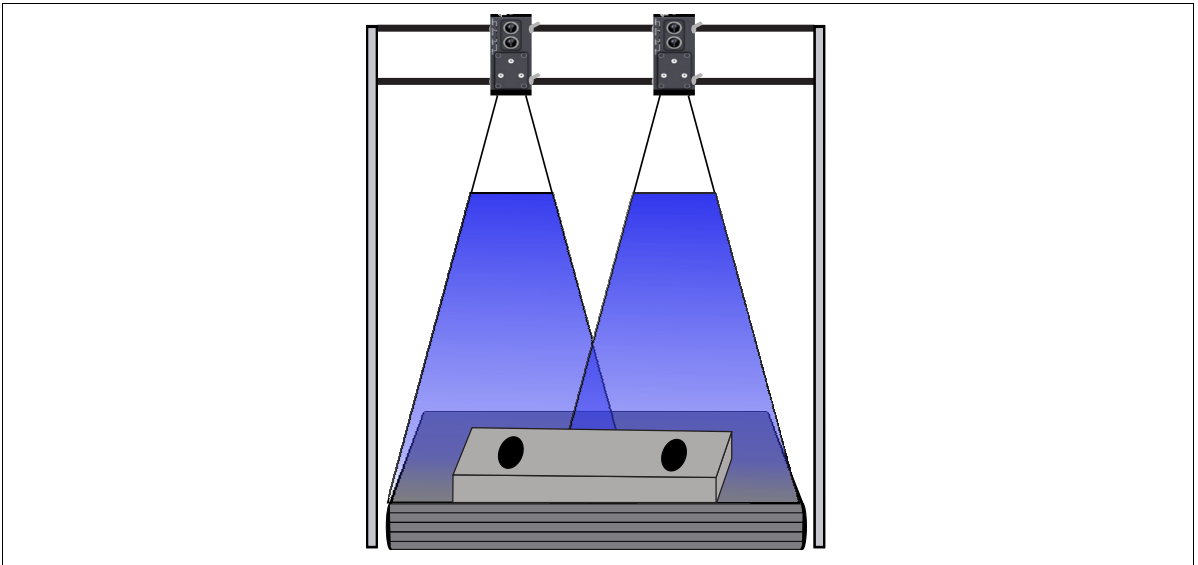

- ❖ When allocating multiple Zebra AltiZ 4200 3D sensors for an acquisition, always allocate the last Zebra AltiZ 4200 in the chain first and allocate the first Zebra AltiZ 4200 in the chain last.

To set up your Zebra AltiZ 4200 3D sensors in multi-altiz configuration, perform the following:

Allocate secondary Zebra AltiZ 4200 first

1. Open Aurora Imaging Capture Works, and allocate the **secondary** Zebra AltiZ 4200 by double-clicking on it in the presented list of available devices or by right-clicking on it and selecting **Alloc**. For additional sensors, repeat the pattern outlined in the *Wiring Zebra AltiZ 4200 in multi-altiz configuration* section, earlier in the chapter.

Configure and allocate main Zebra AltiZ 4200 next

2. Allocate the main Zebra AltiZ 4200 after allocating all of the secondary Zebra AltiZ 4200 sensors by double-clicking on it in the presented list of available devices or by right-clicking on it and selecting **Alloc**.

3. Align your connected 3D sensors by following the alignment instructions in the *How to align your multi-altiz configuration* section previously in this chapter.
 4. In the settings for the main Zebra AltiZ 4200, navigate to the **Quick Setup Control** category and change **Length World (Scan3dVolumeLengthWorld)** to the length of your object. For this example, the object has a length of 140 mm, but to give some extra space for when the scan begins and ends, **Length World (Scan3dVolumeLengthWorld)** has been set to 145 mm. *Multi-AltiZ Plugin Control* section, in *Chapter 5: Zebra AltiZ 4200 GenICam feature reference*.
 5. For this example, set **Motion Input Type (Scan3dMotionInputType)** to **Step**, set **Motion Direction (Scan3dMotionDirection)** to **Same**, and set **Motion Step World (Scan3dMotionStepWorld)** to the displacement between profiles (for example, 2 mm). The relationship between speed, scan displacement, and acquisition line rate is described in the *Specifying scan step when using a constant line (profile) rate* section, in *Chapter 4: Understanding and setting the features of your Zebra AltiZ 4200*.
 6. On the main Zebra AltiZ 4200, set **TriggerSource** to **Line2** so that the frame is triggered by the line connected to the proximity sensor. When using the Multi-AltiZ Plugin, many of the values for trigger features are set automatically to the following:
 - **TriggerSelector** is set to **LineStart**
 - **TriggerMode** is set to **On**
 - **TriggerActivation** is set to **RisingEdge**.
 - **TriggerSource** is set to **Encoder0**
- ❖ In multi-altiz configuration, the output of the main Zebra AltiZ 4200 is sent to the input of the next Zebra AltiZ 4200 in the chain. This is hardwired by the multi-altiz cable and cannot be changed. **Line4** of the main Zebra AltiZ 4200 is sent to **Line0** of the secondary Zebra AltiZ 4200 and **Line5** of the main Zebra AltiZ 4200 is sent to **Line1** of the secondary Zebra AltiZ 4200.

7. Next, configure the encoder settings for the main Zebra AltiZ 4200. Set **EncoderSourceA** to **Line0**, set **EncoderSourceB** to **Line1**, set **EncoderOutputMode** to **Motion**, and set **EncoderResolution** to 0.001 mm, and set **EncoderResetSource** to **AcquisitionStart**.
8. Set **ExposureTime** to an appropriate value. For this example, set **ExposureTime** to 500 μ sec.
9. With the main Zebra AltiZ 4200 still allocated, click on the **Single Grab** toolbar button (). This will prepare all connected Zebra AltiZ 4200 units for acquisition. Once the part begins to move, acquisition will commence.
10. Trigger the encoder and move the stage.

The following is a scan from the combined point clouds of both the main and secondary Zebra AltiZ 4200 in multi-altiz configuration:

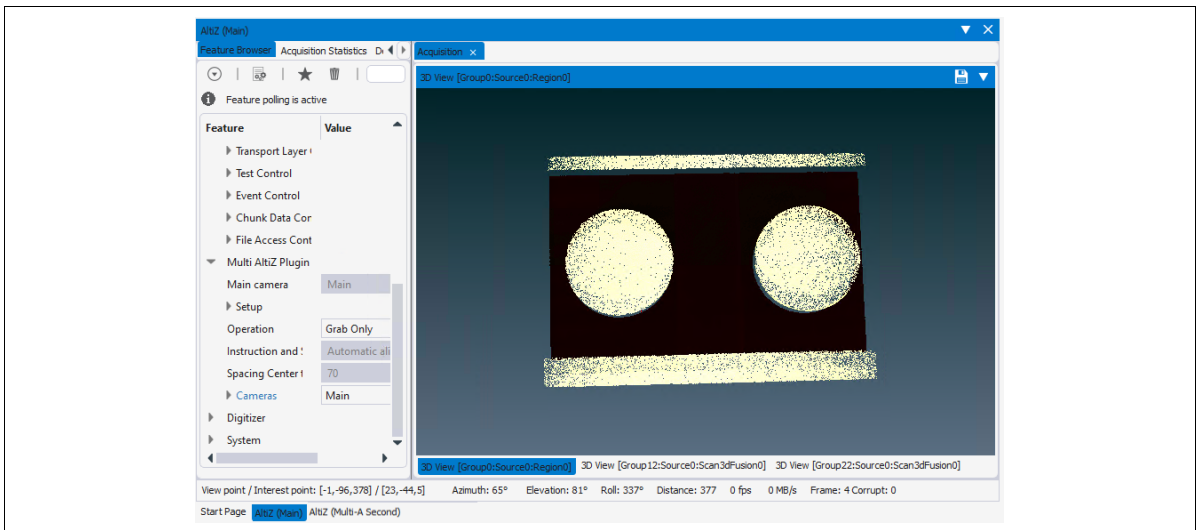

- ❖ The object being scanned in this example is a calibration board that was designed for the specific mounting setup used in this example. When you align your 3D sensors in multi-altiz configuration, you will need to create your own alignment board. For information on how to create your own alignment board, please refer to the *Create an alignment board* section previously in this chapter.

The following is a scan from the main Zebra AltiZ 4200 in multi-altiz configuration:

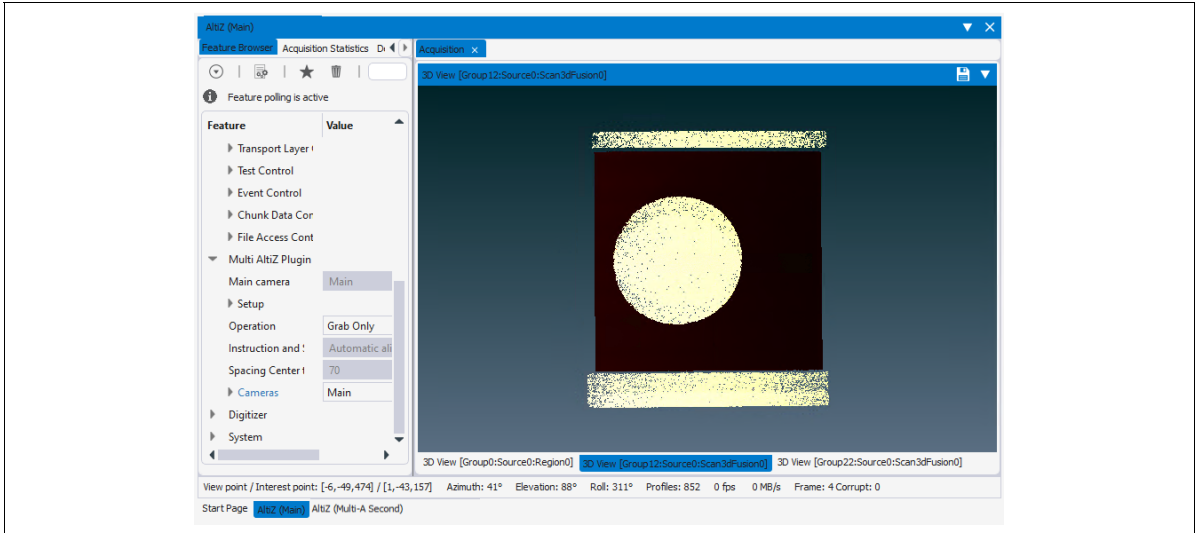

The following is a scan from the secondary Zebra AltiZ 4200 in multi-altiz configuration:

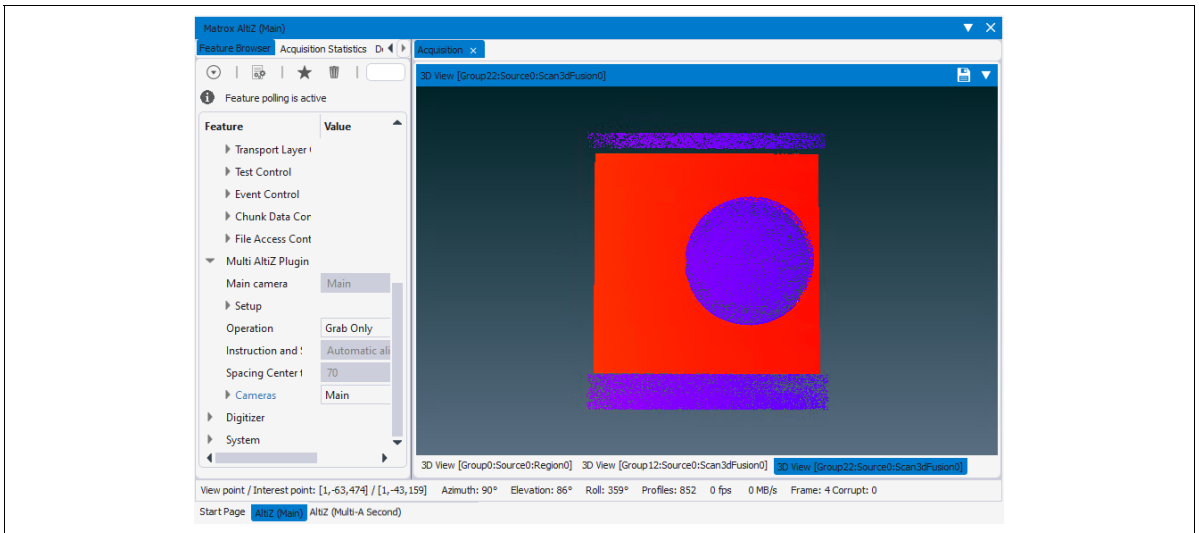

Appendix D: Listing of Zebra Altiz 4200 3D sensors

This appendix lists the key feature changes to the Zebra Altiz 4200 3D sensor.

Key feature changes

Part number	Version	Description
AZ2S2SB	005	First shipping of Zebra AltiZ 4200 with FoV 25.
AZ2S3SB	005	First shipping of Zebra AltiZ 4200 with FoV 50.
AZ2S5SB	005	First shipping of Zebra AltiZ 4200 with FoV 70.

You can always obtain the latest firmware update from the Aurora Imaging Library auto update service, or by visiting the Zebra AltiZ 4200 product page on Zebra's website.

